



Thank you for choosing the EuroVan Camper.

Your new EuroVan was constructed by Volkswagen in their Hannover, Germany assembly plant. Volkswagen has been supplying the world with vans for over 45 years, and the EuroVan reflects this experience.

The mid-sized EuroVan is a heavy-duty vehicle built to endure a wide variety of applications, well beyond that of a typical minivan. This makes it ideal for a camper vehicle, where comfort and driveability must be combined with strength and durability.

The Winnebago camper package was designed, engineered and quality built in Forest City, Iowa. In developing the package, we focused on three primary objectives:

#### I. CAPTURE THE ESSENCE OF THE TRADITIONAL VOLKSWAGEN CAMPER.

To accomplish this we had to provide the most efficient use of space possible, and deliver a high level of material and workmanship quality.

Thanks to Volkswagen's long wheelbase, the EuroVan Camper has more interior volume than the previous model, the Vanagon Camper. We believe that we have found the optimum blend of storage and living area within this larger space. Even the refrigerator is a special design to fit two cubic feet into the smallest possible galley space.

Regarding quality and durability, we hope that many of our efforts are easily recognizable, even to the casual observer. However, what would not be obvious, for example, is the fact that the entire galley is anchored by an aluminum frame, tig-welded together and then electro-statically "powder painted". Or that the cabinet panels are solid-core wood covered with high-pressure laminates.

Even the "pop-up" top is Winnebago's own design and construction. Here we use an aluminum frame and high-density foam, sandwiched between two polymer sheets. The result is an insulated top that is much stronger than Fiberglass, and somewhat lighter in weight.

#### II. MAXIMIZE VERSATILITY.

Typical camper-vans are good campers, but not very capable at hauling people or things. With the EuroVan Camper, we set out to ensure that on any given day, it can be a complete camper, a roomy passenger van, or an effective cargo van.

This versatility comes from the galley-left layout, combined with an optional center seat, and the fact that the center and rear seats are easily folded or removed. The result is room for up to six full-sized people or a remarkable variety of cargo (or many things in between!)

### III. MAXIMIZE VALUE

Winnebago's past success is not based upon selling the lowest price motor home, but instead on being the best value. In fact, Winnebago won seven of eleven 1993 "Best Buy" awards given to motor homes that Consumer's Digest felt had the best value for the American consumer.

In the development of the EuroVan Camper package, we called upon several proven suppliers for high quality components and appliances that can be readily serviced in the United States or Canada. We also produce many of the components ourselves to ensure a high level of quality at a reasonable cost.

In market research clinics, we spoke with many past and present Volkswagen camper owners about what drew them to their campers. From them, the message was quite clear:

- A. Volkswagen Camper buyers are not looking for a cheap product, but they demand value.
- B. Volkswagen Camper buyers do not want "fluff", they want practical features that make sense.
- C. Volkswagen Camper buyers expect versatility, durability and quality.

As a total package, Winnebago believes that the EuroVan Camper lives up to these requirements. We hope that your own experience with the EuroVan Camper exceeds your expectations. Thank you again for your purchase.

WILLIAM J. O'LEARY  
Vice President, Product Development

OWNER'S NAME
STREET ADDRESS
CITY AND STATE (OR PROVINCE IN CANADA)
MOTOR HOME SERIAL NUMBER
VEHICLE CHASSIS IDENTIFICATION NO. (VIN)
DATE OF DELIVERY TO FIRST RETAIL PURCHASER
VEHICLE MILEAGE AT TIME OF DELIVERY
SELLING DEALER NAME AND ADDRESS



**2002 NEW VEHICLE LIMITED WARRANTY  
WINNEBAGO INDUSTRIES, INC.  
EUROVAN CAMPER**

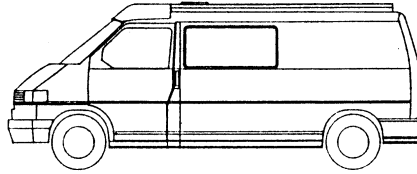

**WARRANTY COVERAGE TO OWNER**

Winnebago Industries, Inc. of Forest City, Iowa warrants the portion of each new Eurovan manufactured or installed by it (excluding those items listed under Items Not Covered) to the owner for use in U.S. and Canada as follows:

**WARRANTY PERIOD**

For the period of 24 months or 24,000 miles on the odometer, whichever occurs first, from the date the vehicle is delivered to the first retail purchaser or first placed in service as a dealer demonstrator, whichever occurs first. Winnebago does not authorize any person to create for it any other obligations or liability in connection with this vehicle. ANY IMPLIED WARRANTY OF MERCHANTABILITY OR FITNESS FOR A PARTICULAR PURPOSE APPLICABLE TO THIS VEHICLE IS LIMITED IN DURATION TO THE DURATION OF THIS WRITTEN WARRANTY AS HEREINBEFORE OR HEREINAFTER PROVIDED. THE PERFORMANCE OF REPAIRS AND NEEDED ADJUSTMENTS IS THE EXCLUSIVE REMEDY UNDER THIS WRITTEN WARRANTY OR ANY IMPLIED WARRANTY. WINNEBAGO SHALL NOT BE LIABLE FOR INCIDENTAL OR CONSEQUENTIAL DAMAGES FOR LOSS OF TIME, INCONVENIENCE, OR OTHER CONSEQUENTIAL DAMAGE INCLUDING EXPENSE FOR GASOLINE, TELEPHONE, TRAVEL, LODGING, LOSS OR DAMAGE TO PERSONAL PROPERTY, OR LOSS OF REVENUE RESULTING FROM BREACH OF THIS WRITTEN WARRANTY OR ANY IMPLIED WARRANTY. Some states do not allow limitations on how long an implied warranty will last or the exclusion or limitation of incidental or consequential damages, so the above limitations or exclusions may not apply to you.

This warranty gives you specific legal rights and you may also have other rights which vary from state to state.

**ITEMS NOT COVERED UNDER WARRANTY BY WINNEBAGO INDUSTRIES, INC.**

The following items are covered by separate warranties issued by their respective manufacturers and are not warranted by Winnebago. Consult separate warranty documents for the terms and conditions established by the manufacturers of these components:

- Chassis (Volkswagen)
- Batteries
- Radio
- Tires
- Wheels

Also, this warranty shall not apply to failures, damages or malfunctions resulting from normal wear, misuse, abuse, negligence, alteration, accident, fire, improper repair of the vehicle or failure to follow recommended maintenance requirements.

Also, Winnebago cannot and does not accept any responsibility in connection with any of its Eurovans for additional equipment or accessories installed at any dealership or other place of business, or by any other party other than Winnebago. Such installation of equipment or accessories by any other party will not be covered by the terms of this warranty.

**WINNEBAGO'S RESPONSIBILITY**

Any part of the Winnebago Eurovan subject to this warranty which is found to be defective in material or workmanship, will be repaired or replaced at Winnebago Industries' option without charge to the customer for parts or labor. The owner may obtain warranty repairs or replacement of such items at any authorized Winnebago Dealership.

\_\_\_\_\_  
\_\_\_\_\_  
\_\_\_\_\_

PLACE  
STAMP  
HERE

Winnebago Industries, Inc.  
P.O. Box 152  
Forest City, Iowa 50436

ATTENTION: WARRANTY DEPT.

**CARE AND MAINTENANCE**

Defects or damage to appearance items such as fiberglass, metal, paint, fabrics and trim, may occur during manufacturing or transporting. Normally, any factory defect or damage is corrected at the factory. In addition, dealers are obligated to inspect each vehicle upon delivery to them and prior to delivery to you. You should also immediately inspect for appearance defects and advise your selling dealer without delay, as damage and normal deterioration due to use and exposure is not covered by this warranty.

**IF REPAIRS ARE NEEDED**

If a part of the system covered by this warranty fails to function or requires service during the warranty period:

1. Take the Eurovan to the selling dealer or authorized Winnebago dealer as specified under the WINNEBAGO RESPONSIBILITY section of this warranty, for repair.
2. If the dealer is unable to make the repair, he can contact Winnebago Industries, Inc. for technical or parts assistance.
3. If, after the above steps are completed and the repair is not made, the customer should contact Winnebago Industries, Inc., P.O. Box 152, Forest City, Iowa 50436, Attention: Owner Relations Department (641-585-6939) and furnish the following information:
  - The complete serial number of the Eurovan
  - Date of retail purchase
  - Selling dealer's name
  - Nature of the service problem and a brief explanation of the steps or services the dealer has performed, and the results obtained.

The customer may be directed to another dealer or service center for repairs to be completed, if such dealer or service center is better able to complete the repair.

4. If after the above steps are completed and the repairs are not completed, the customer can:
  - Contact the Service Administration Manager of Winnebago Industries and request a customer relations board meeting to resolve the problem. This action, however, is not mandatory.

**DEALER'S REPRESENTATIONS EXCLUDED**

Winnebago Industries, Inc. does not undertake the responsibility to any purchaser of its products for any undertaking, representation or warranty made by dealers selling its product beyond those herein expressed.

**CHANGES IN DESIGN**

Winnebago Industries, Inc. reserves the right to make changes in design and changes or improvements upon its products without imposing any obligation upon itself to install the same upon its products theretofore manufactured.

PART NO. 701677-J7-000

-----CUT HERE-----

**NOTICE OF SECOND OWNER**

ORIGINAL OWNER	NAME	
	ADDRESS	
NEW OWNER	NAME	
	ADDRESS	ZIP CODE
WINNEBAGO IDENTIFICATION NUMBER	VEHICLE MILEAGE	DATE
CHASSIS IDENTIFICATION	NEW OWNER SIGNATURE	

**IMPORTANT:** THIS NOTICE IS TO BE USED ONLY FOR RECORD KEEPING BY WINNEBAGO INDUSTRIES

The completed form does not constitute an actual change of ownership.

**INTRODUCTION**

Operators Manual .....	0-1
Owner Information Binder.....	0-1
Options and Equipment .....	0-1
Warranty .....	0-1
Service Assistance .....	0-1
Drinking and Driving.....	0-2
Reporting Safety Defects .....	0-2
Exterior Features.....	0-3
Tank Capacities.....	0-3
Interior Features.....	0-4

**SECTION 1: SAFETY PRECAUTIONS**

Seat Belts .....	1-1
General Warnings.....	1-2
Fuel & LP Gas .....	1-3
LP Gas Leaks .....	1-4
LP Gas Alarm .....	1-4
Electrical .....	1-5
Loading .....	1-5
Formaldehyde Warning.....	1-5
Carbon Monoxide Alarm .....	1-6
Smoke Alarm .....	1-6
Fire Extinguisher.....	1-7
Rear Liftgate Exit.....	1-7

**SECTION 2: LP GAS SYSTEM**

LP Gas Supply .....	2-1
Safe Use of LP Gas System .....	2-1
How LP Gas Works .....	2-1
Selecting Fuel Types.....	2-1
LP Tank System .....	2-2
Refilling LP Tank.....	2-2
Air in the LP Gas Tank .....	2-3
Travel with LP Gas .....	2-3
Regulator.....	2-4
LP Gas Leaks .....	2-4
Winter Use of LP Gas .....	2-5
How Long Will a Tank Last? .....	2-5

**SECTION 3: ELECTRICAL SYSTEM**

110-Volt AC System .....	3-1
External Power Cord (Shoreline).....	3-1
110-Volt Outlets .....	3-2
110-Volt Circuit Breaker.....	3-2
Ground Fault Circuit Interrupter (GFCI).....	3-2
Power Control Center .....	3-2
Thermal Breaker .....	3-3
Power Converter Charging Section .....	3-3
12-Volt DC System .....	3-3

Automotive Battery.....	3-3
Auxiliary (Coach) Battery .....	3-3
12-Volt Outlets .....	3-4
12-Volt Circuit Breakers .....	3-4
Coach Battery Circuit Breaker.....	3-4
Battery Storage and Maintenance .....	3-5
Battery Condition Meter .....	3-5

**SECTION 4: PLUMBING SYSTEMS**

Galley Sink Faucet.....	4-1
Rear Sprayer Head .....	4-1
Filling Fresh Water Tank .....	4-1
Disinfection of Fresh Water Tank .....	4-2
Water Drain Valve.....	4-2
Waste Water Holding Tank .....	4-3
Dumping Holding Tank .....	4-3
Holding Tank Level Indicators .....	4-3

**SECTION 5: RV FEATURES AND APPLIANCES**

RV Interior Features (Illustration) .....	5-1
Refrigerator.....	5-2
Range Top.....	5-3
Monitor Panel .....	5-4
Water and Holding Tank Levels .....	5-5
LP Gas Level .....	5-5
Battery Condition Meter .....	5-5
LP Gas Furnace.....	5-5
Humidity and Condensation .....	5-5
Pop-Up Roof.....	5-6
Sleeping Facilities.....	5-7
Upper Bed.....	5-7
Rear Bench Seat/Bed .....	5-8
Center Bench Seat.....	5-10
Child Restraint Tether Anchors .....	5-11
Center Companion Seat .....	5-12
Tables .....	5-12
Interior Lights .....	5-12
Side Tip-Out Window .....	5-13
Side Slider Window .....	5-13
Front & Rear Curtains.....	5-13
Pleated Side Window Shades.....	5-13
Luggage Tray (Roof) .....	5-13
Radio/Cassette Player .....	5-14
Rear Storage Compartment.....	5-14

**SECTION 6: CARE AND STORAGE**

Care of Pop-Up Roof Canvas .....	6-1
Upholstery.....	6-1
Vinyl Fabrics.....	6-1
Cabinets .....	6-1

**TABLE OF CONTENTS**

---

Tables and Galley Cover ..... 6-1  
Stainless Steel Sink and Countertop ..... 6-2  
Range and Refrigerator ..... 6-2  
Cold Weather Storage (Winterizing) ..... 6-2  
Removal from Storage ..... 6-3

**SECTION 7: TRAVELING WITH YOUR  
CAMPER**

Vehicle Weight ..... 7-1  
Trailer Towing ..... 7-1  
Pre-Travel Checklist ..... 7-1  
Severe Weather Information ..... 7-1  
Campsite Set-Up (Leveling) ..... 7-2

---



Congratulations on the purchase of your new EuroVan Camper. This conversion package has been carefully designed, engineered and quality built by Winnebago Industries, Inc.

### **OPERATOR'S MANUAL**

Please read this operator's manual and the Volkswagen EuroVan Owners Manual thoroughly. They provide you with information necessary to properly and safely operate the vehicle and the equipment in your camper.

This manual describes those instruments, controls and instructions which are unique to this motor home. For information on the automotive equipment, controls, special seat belt usages and instructions not described in this manual, we urge you to read the Volkswagen EuroVan Owner's Manual and the equipment manufacturer's information provided in your Owner Information binder.

This manual should be kept in the vehicle at all times for personal reference. The operator's manual, owner information binder and Volkswagen EuroVan operating guide are to be considered permanent components of this vehicle. They should remain in the vehicle when sold to provide the next owner with important safety, operating and maintenance information.

*NOTE: The descriptions, illustrations, and specifications in this manual were correct at the time of printing. We reserve the right to change specifications or design without notice, and without incurring obligation to install the same on products previously manufactured.*

Throughout this manual, reference is made to the following terms: Note, Caution and Warnings. These terms indicate important information which must be understood and followed. The definitions of these terms are:

*NOTE: Indicates a special point of information.*

#### **CAUTION**

Indicates that a failure to observe can cause damage to vehicle or equipment

#### **WARNING**

This symbol is used to alert you to precautions that involve your personal safety as well as vehicle damage. Read and follow them carefully.

### **OWNER INFORMATION BINDER**

Your Owner Information binder contains information supplied by manufacturers of individual appliances and equipment installed in your Winnebago camper.

Consult this information regarding the operation and care of appliances, accessories and special equipment.

### **OPTIONS AND EQUIPMENT**

Some equipment and accessories described in this manual may be optional and may not apply to your vehicle.

### **WARRANTY**

The camper conversion components (e.g. pop-up roof, cabinets, appliances, automotive radio, etc.) in your new EuroVan Camper are covered against defects in material and workmanship by a Winnebago factory warranty. This warranty should be validated immediately and returned to the factory by your dealer. For detailed information on what the Winnebago warranty includes, see the New Vehicle Limited Warranty included in our Owner Information binder.

### **SERVICE AND ASSISTANCE**

Your EuroVan Camper dealer will be glad to provide any additional information you need, as well as answer any questions you might have about operating the equipment in your camper. When it comes to service, remember that your dealer knows your vehicle best and is interested

## INTRODUCTION

---

in your satisfaction. Your dealer will provide quality maintenance and any other assistance that you may require during your ownership of this vehicle.

If you need warranty repairs to the camper equipment while traveling, however, you may take your vehicle to any Winnebago or Itasca dealership because they are authorized to assist you.

## DRINKING AND DRIVING

Winnebago Industries supports the recommendations of the Presidential Commission on Drunk Driving.

- Exercise your good judgment and encourage others to do the same.
- Know the legal limits and do not exceed them.
- Also know your personal limits, which may be lower than the legal limits.
- Should you ever exceed your limits, find alternative transportation; call a cab, ask a friend to drive you home or call a family member to come and get you.

The presence of alcohol in significant levels in the blood increases the probability that the driver will be involved in an accident.

## REPORTING SAFETY DEFECTS

If you believe that your vehicle has a defect which could cause a crash or could cause injury or death, you should immediately inform the National Highway Traffic Safety Administration (NHTSA) in addition to notifying Winnebago Industries, Inc.

If NHTSA receives similar complaints, it may open an investigation, and if it finds that a safety defect exists in a group of vehicles, it may order a recall and remedy campaign. However, NHTSA cannot become involved in individual problems between you, your dealer, or Winnebago Industries.

To contact NHTSA, you may either call the Auto Safety Hotline toll-free at 1-800-424-9393 (or 366-0123 in Washington, D.C. area) or write to: NHTSA, U.S. Department of Transportation, Washington, D.C. 20590. You can also obtain other information about motor vehicle safety from the Hotline.

**EXTERIOR FEATURES**

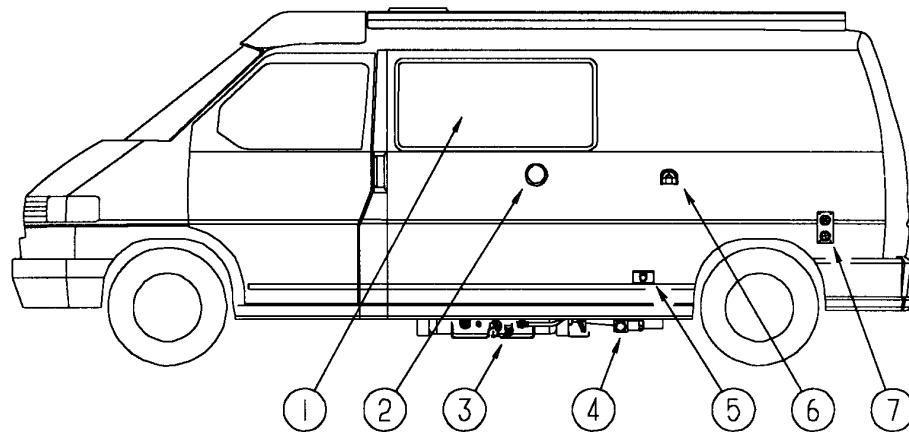

- |                                     |                                   |
|-------------------------------------|-----------------------------------|
| 1. Tip-Out Window                   | 7. Furnace Exhaust Vent**         |
| 2. Refrigerator Heat Exhaust Vent** | 8. Coach Battery Compartment Vent |
| 3. LP Gas Tank Controls/Fill Valve  | 9. Slider Window                  |
| 4. Waste Water Tank Dump Valve      | 10. Pop-Up Roof                   |
| 5. 110-Volt Shoreline Input Plug    | 11. Roof Vent                     |
| 6. Holding Tank Vent                | 12. Luggage Tray                  |

\*\*CAUTION: Be careful. These features may become hot while refrigerator or furnace are in use.

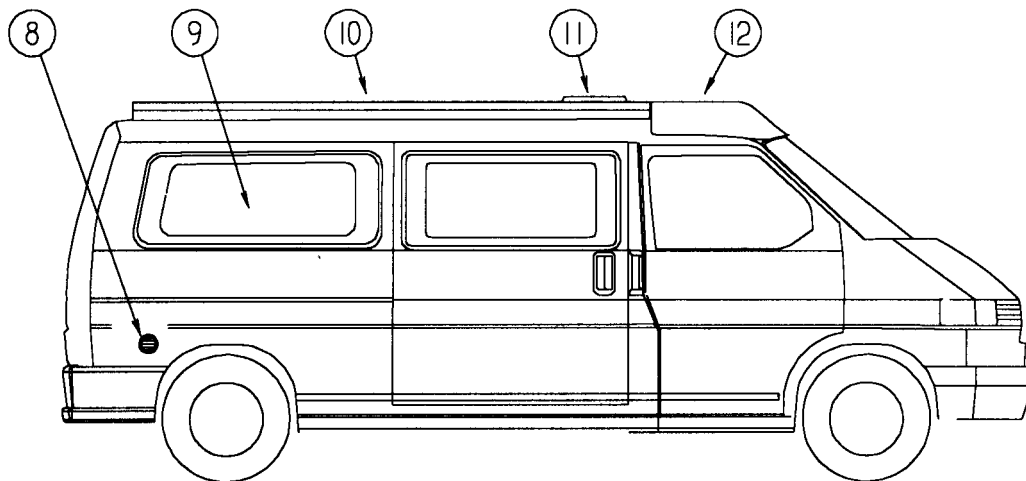

**TANK CAPACITIES**

Vehicle Fuel Tank .....	21.1 gal.
LP Gas Tank (tank size) .....	20 lbs./4.6 gal.
(usable full cap.) .....	16 lbs./3.7 gal.
Fresh Water Tank .....	12 gal.
Waste Water Holding Tank .....	8 gal.

Your EuroVan Camper has many convenient, self-contained RV features.

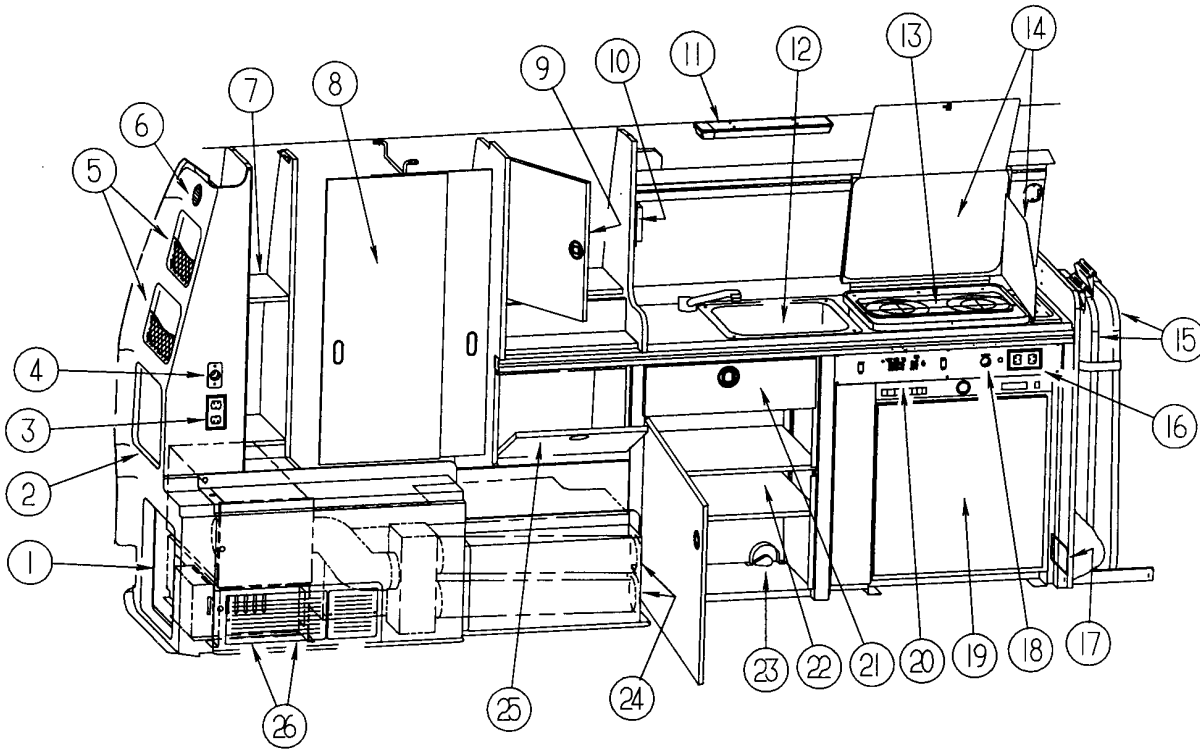

- |                                   |                                    |
|-----------------------------------|------------------------------------|
| 1. Camper Electrical Power Center | 14. Range Burner Spatter Shields   |
| 2. Water Center                   | 15. Table Storage                  |
| 3. 110-Volt AC Outlet             | 16. 110-Volt AC Outlet             |
| 4. 12-Volt DC Outlet              | 17. LP Gas Alarm                   |
| 5. Storage Pockets                | 18. 12-Volt DC Outlet              |
| 6. Cold Air Return Grille         | 19. Refrigerator - AC/DC/Gas       |
| 7. Storage Shelves                | 20. System Monitor Panel           |
| 8. Wardrobe/Storage Closet        | 21. Utensil Drawer                 |
| 9. Storage Cabinet 2/Mirror       | 22. Storage Cabinet                |
| 10. Furnace Thermostat            | 23. Water Line Drain               |
| 11. Fluorescent Light             | 24. Furnace Heat Vents             |
| 12. Galley Sink & Faucet          | 25. Storage Cabinet                |
| 13. LP Gas Range Top              | 26. Furnace Cold Air Return Grille |

Read and understand all instructions and precautions in both manuals before operating your new camper. The symbol **WARNING** is used throughout this manual to alert you to precautions that involve your personal safety. Read and follow them carefully. Listed are some safety precautions that must be adhered to. These precautions as well as others that involve damage to equipment are also listed in the appropriate areas in this manual.

### **SEAT BELTS**

Seats intended for occupancy while the vehicle is in motion are equipped with seat belts for the protection of the driver and passengers. The lap belts must be worn as low as possible and fit snugly across the hip area. Always sit erect and well back into the seat. To gain full protection of the safety belt, never let more than one person use the same safety belt at any one time, and do not let the safety belts become damaged by pinching them in the doors or in the seat mechanism. After any serious accident, any safety belts which were in use at the time should be replaced.

#### **WARNING**

This manual does not include information on very important safety considerations and warning related to "Safety Belts" and "Child Safety". Be sure to check the Volkswagen Vehicle Owner's Manual for this information on occupant restraint systems and child safety and also for additional instructions relating to the vehicle.

Although federal law provides for additional, separate lap belt on swivel seats, Winnebago recommends for your safety and the safety of all occupants, that you always use the combination lap-shoulder belt and not the separate lap belt while this vehicle is moving. Never drive the vehicle unless the swivel seat is locked in the forward facing position.

### **CENTER COMPANION SEAT BELTS**

See your Volkswagen Vehicle Owner's Manual for information regarding care and use of safety belts for the optional center companion seat.

### **CENTER BENCH SEAT LAP BELTS**

The seat belts in the rear of your camper are equipped with automatic locking retractors that let you easily adjust your seat belt to the proper length for passenger safety.

- Grasp the end of the belt and pull smoothly outward from the seat to the required length, then insert into buckle. Be sure belt is not twisted before fastening.
- Feed any excess belt length back toward the seat so the belt retractor will lock the belt at the proper length for your body when released.
- Do not jerk the belt or pull out too quickly because it will lock prematurely and require you to reset the belt retractor.
- Reset the belt retractor by letting the belt go all the way back to the starting point, then pull slowly and smoothly outward.
- Only seats equipped with seat belts are to be occupied while the vehicle is moving
- To unfasten the lap belt, press the release button on the buckle. Hold onto the end of the belt when you release it from the buckle to keep it from retracting too rapidly.

*NOTE: When using the lap belt to restrain a child seat, pull the seat belt out all the way and hold it with one hand while you use your other hand to thread the tongue of the belt through the slots in the child car seat. After threading the belt through the child seat, latch the belt securely. Feed any excess belt length back into the retractor so that it locks snugly. The belt should be tight enough to hold the child car seat securely against the seat.*

### WARNING

To reduce the risk of an injury in an accident, position the lap belt tightly and as low as possible across the pelvis. Pregnant women should be especially certain to wear the lap belt as low as possible across the pelvis so there is no pressure on the abdomen. Only seats equipped with seat belts are to be occupied while the vehicle is in motion.

## REAR BENCH SEAT 3-POINT LAP SHOULDER BELTS

**Fastening:** Hold the belt just behind the tongue using the hand nearest to the sidewall. Next, bring the belt across the body and slide the tongue into the buckle until the latch engages.

Do not pull the belt away from the wall too quickly or it will “lock” and prevent you from pulling it any farther. If this happens, relax your pull on the belt slightly, then continue pulling it less quickly.

*NOTE: When using the lap/shoulder belt to restrain a child seat, pull the seat belt out all the way and hold it with one hand while you use your other hand to thread the tongue of the belt through the slots in the child car seat. After threading the belt through the child seat, latch the belt securely. Adjust the tongue portion of the latch so that it is tight enough to hold the child car seat securely against the seat.*

**Unfastening:** Press the release button in the buckle. Hold onto the tongue when you release it from the buckle to keep it from retracting too rapidly.

When the lap-shoulder belt is in use, the lap portion must ride across the strong hip area and the shoulder portion must ride diagonally over the shoulder blade toward the buckle.

The shoulder belt is designed to lock only during a sudden stop, sudden body movement or a collision. At all other times it will move freely with the occupant.

### WARNING

Never wear the shoulder belt in any position other than as stated above. Failure to do so could increase the chance or extent of injury in a collision.

## GENERAL WARNINGS

- Only seats equipped with seat belts are to be occupied while the vehicle is moving.
- Make sure all passengers have seat belts fastened in a low and snug position so the force exerted by the belt in a collision will be spread across the strong hip area. Pregnant women should wear a lap-shoulder belt whenever possible, with the lap belt portion worn low and snug throughout the pregnancy.
- All moveable or swiveling seats should be placed and locked in forward facing positions while the vehicle is moving.
- Never let passengers stand or kneel on seats while the vehicle is moving.
- Sleeping facilities are not to be utilized while vehicle is moving.
- Examine the escape window and be familiar with its operation, but do not use except in an emergency.
- Inspect the fire extinguisher monthly for proper charge and operating condition. This should also be done before beginning a vacation or any extended trip.

## DRIVING

- Do not attempt to adjust the driver’s seat while the vehicle is moving.
- Do not adjust tilt steering in a moving vehicle.
- Do not operate the cruise control on icy or extremely wet roads, winding roads, in heavy traffic, or in any other traffic situation where a constant speed cannot be maintained.
- Use care when accelerating or decelerating on a slippery surface. Abrupt speed changes can cause skidding and loss of control.

- Driving through water deep enough to wet the brakes may affect stopping distance or cause the vehicle to pull to one side. Check brake operation in a safe area to be sure they have not been affected. Never operate any vehicle if a difference in braking efficiency is noticeable.
- Adverse weather conditions and extremes in terrain may affect handling and/or performance of your vehicle. Refer to your chassis manual for related information.
- The fire extinguisher should be inspected monthly for proper charge and operating condition. This should also be done before beginning a vacation or any extended trip.

## FUEL & LP GAS

- The rangetop, refrigerator and furnace must be turned off while refilling the fuel tank or LP tank.
- Never smoke while refilling vehicle fuel tank or LP gas tank.
- Avoid inhaling exhaust gases produced by burned gasoline, or LP gas in items such as the chassis engine, range, refrigerator, and furnace. They contain carbon monoxide, which is an odorless, colorless and poisonous gas. (See Carbon Monoxide Alarm, page 1-5.)
- Do not bring or store LP gas containers, gasoline or other flammable liquids inside the vehicle because a fire or explosion may result. LP gas containers are equipped with safety valves which relieve excessive pressure by discharging gas to the atmosphere.
- Do not alter the LP gas system at any time or in any way.
- Do not fill LP gas tank above 80 percent of capacity. Overfilling the LP gas container can result in uncontrolled gas flow which can cause fire or explosion. A properly filled container will contain approximately 80 percent of its volume as liquid LP gas.
- Never use an open flame to test for LP gas leaks. Close tank valve and replace all protective covers and caps on LP system after filling.
- Never connect natural gas to the LP gas system.
- When lighting range burners do not turn burner controls to "On" and allow gas to escape before lighting match.
- Do not use portable fuel-burning equipment, including wood and charcoal grills and stoves, inside the recreational vehicle. Use of this equipment inside the recreational vehicle may cause fires or asphyxiation.
- LP gas regulators must always be installed with the diaphragm vent facing downward. Regulators that are not in compartments have been equipped with a protective cover. Make sure that the regulator vent faces downward and that the cover is kept in place to minimize vent blockage which could result in excessive gas pressure causing fire or explosion.
- The following warning label is located in the cooking area to remind you to provide an adequate supply of fresh air for combustion.



Unlike large homes, the oxygen supply inside a recreational vehicle is limited due to its size. To avoid danger of asphyxiation, provide proper ventilation when using the gas rangetop or gas oven. It is especially important that the gas oven or range top not be used for comfort heating. Danger of asphyxiation is greater when these appliances are used for long periods of time.

- When using the range top, raise the pop-up roof and open a vent or canvas side flap to provide sufficient ventilation.

## LP GAS LEAKS

The following label is located in the vehicle near the range area. If you smell gas within the vehicle, quickly and carefully perform the procedures listed.

### IF YOU SMELL GAS

1. Extinguish any open flames, pilot lights and all smoking materials.
2. Do not touch electrical switches.
3. Shut off the gas supply at the tank valve(s) or gas supply connection.
4. Open doors and other ventilating openings.
5. Leave the area until odor clears.
6. Have the gas system checked and leakage source corrected before using again.

## LP GAS ALARM

Your camper is equipped with an LP gas detector which sounds an alarm if an unsafe amount of LP gas is present inside the coach. Because LP gas is heavier than air and will settle to the floor, the detector is located on a cabinet face near the floor of the vehicle behind the driver's seat.

A green light on the face of the alarm shows when the unit is active. The red button is used to reset the alarm.

Press to stop alarm sound

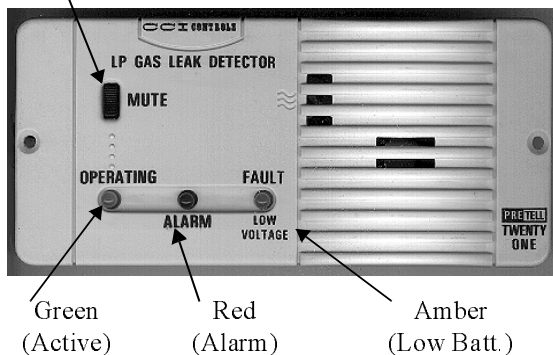

### If The Alarm Sounds

If the alarm sounds, do not touch any electrical switches. Immediately turn off the main LP tank valve and all LP appliances, open all win-

dows and roof vents, and leave the vehicle until the alarm stops sounding.

If the alarm keeps sounding at regular intervals, a leak may be present. Contact your dealer or an LP gas service center to have the problem corrected before using the LP system again.

### WARNING

Never use an open flame to test for gas leaks.

If testing for gas line leaks with a soapy water solution, DO NOT use a detergent containing ammonia or chlorine. These substances may generate a chemical reaction causing corrosion to gas lines, resulting in dangerous leak conditions.

## Power Connection

The LP gas alarm is powered by the coach batteries. If the battery cable is disconnected from the battery or the fuse is blown, the alarm will not work. The LP gas alarm fuse is located on the circuit breaker panel in the rear of the vehicle.

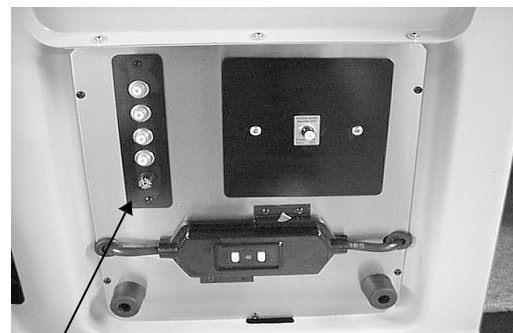

LP Alarm Fuse

Because the LP gas alarm is connected directly to the auxiliary battery, it is always drawing a small amount of current. Even though this current draw is slight, it could drain the coach battery during storage periods of 30 days or longer. We recommend disconnecting the battery cables from the auxiliary battery during extended storage periods to avoid discharge.



**Further Information**

See the manufacturer's information entitled "Your LP Gas Detector" in the Owner Information binder for further instructions on nuisance alarms and care and testing of the LP gas detector.

**ELECTRICAL**

- Careless handling of electrical components can be fatal. Never touch or use electrical components or appliances while feet are bare, while hands are wet, or while standing in water or on wet ground.
- Improper grounding of the vehicle can cause personal injury. Do not plug the utility power cord into an outlet which is not grounded and do not adapt the plug to connect to a receptacle for which it is not designed.
- Do not attach an extension cord to the utility power cord.
- Be sure that all electrical appliances to be used contain 3-prong plugs for proper grounding.
- Avoid overloading electrical circuits. Replace fuses or circuit breakers with those of the same size and amperage rating only. Never use a higher rated fuse or breaker.
- Use caution when handling or working near electrical storage batteries. Always remove jewelry and wear protective clothing and eye covering. Avoid creating sparks.

**LOADING**

- Store or secure all loose items inside the motor home before traveling.
- Never load the vehicle in excess of the gross vehicle weight rating or the gross axle weight rating for either axle.

**FORMALDEHYDE INFORMATION****WARNING**

Some components in this vehicle contain formaldehyde based adhesives which may release formaldehyde fumes into the air for an unknown period of time until total dissipation occurs. Individuals who are allergic to formaldehyde gas fumes may experience irritation to eyes, ears, nose and throat. Reaction in infants may be more severe. Although long range effects are not well understood, testing to date has not revealed any serious health effects in humans at the level of emission from these products.

*NOTE: To aid in dissipation, ventilate the vehicle by opening all windows and circulating the air with a fan.*

**CARBON MONOXIDE WARNING****WARNING**

Avoid inhaling exhaust gases, as they contain carbon monoxide, which is a colorless, odorless and poisonous gas.

If you suspect that exhaust fumes are entering the passenger compartment, have the cause determined and corrected as soon as possible. If you must drive under these conditions, drive only with **ALL WINDOWS FULLY OPENED**.

The best protection against carbon monoxide entry into the vehicle body is a properly maintained engine exhaust and ventilation system. It is recommended that the exhaust system and body be inspected by a qualified Volkswagen service center.

- Each time the vehicle is raised for an oil change.
- Whenever a change in the sound of the exhaust system is noticed.

- Whenever the exhaust system, underbody or rear of the vehicle is damaged.

To allow proper operation of the vehicle's ventilation system, keep front ventilation inlet grill clear of snow, leaves or other obstructions at all times. **DO NOT OCCUPY A PARKED VEHICLE WITH ENGINE RUNNING FOR AN EXTENDED PERIOD.**

Do not run engine in confined areas, such as a garage, except to move vehicle in or out of area. When vehicle is stopped in an UNCONFINED area with the engine running for any more than a short period, adjust heating or cooling system to force outside air into the vehicle as follows:

1. Set fan to medium or high speed and vent control to air.
2. On vehicles equipped with air conditioning, set fan to medium or high speed and set control to obtain maximum vent air.

Rear liftgate should be closed while driving to avoid drawing dangerous exhaust gases into the vehicle.

## CARBON MONOXIDE ALARM

If your coach is equipped with a carbon monoxide (CO) alarm, it will be located on the ceiling of the pop-up roof. The CO alarm is powered by a battery/sensor pack and is designed to detect toxic carbon monoxide gas fumes resulting from incomplete combustion of fuel. It will detect CO gas from any combustion source such as the chassis engine, furnace, gas range and refrigerator.

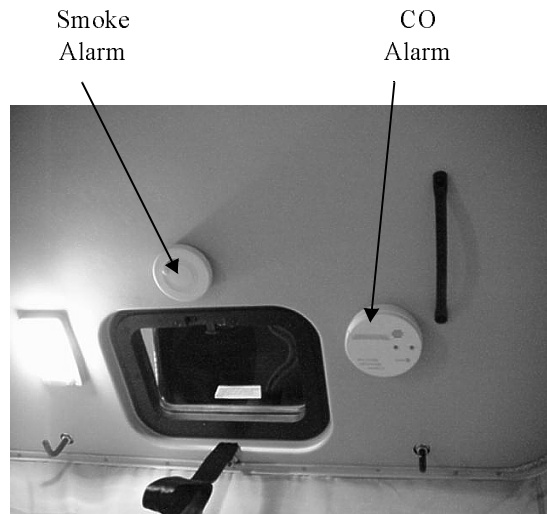

Pop-Up Roof Ceiling

*NOTE: LP gas combustion fumes released during normal cooking can cause a false alarm if there is insufficient ventilation. Open a window, vent, or side flap while using the range top.*

### Further Information

Please read the information provided by the manufacturer, which is included in your Motor Home Operations Manual binder. It includes information on precautions, operational testing, and battery/sensor replacement.

## SMOKE ALARM

Your motor home is equipped with a smoke alarm located on the ceiling of the pop-up roof. This alarm meets U.L. Standard 217 and NFPA Standard 74 for operation of smoke detection devices.

1. The smoke alarm should be tested for correct operation each time the vehicle is brought out of storage, before each trip, and at least once a week during motor home use. To test the electronics, firmly depress the button. To test that smoke reaches the sensor, blow smoke in a careful, fire-safe manner into your smoke alarm.
2. Your smoke alarm will not work without power. Never remove the battery to quiet the

alarm. When your smoke alarm “beeps” about once a minute the battery is weak. Install a new battery immediately. Be sure to use only batteries specified in manual or on unit. Test unit after installing a new battery.

3. Clean and vacuum the openings on your smoke alarm once a month.
4. Do not open the smoke alarm or try to repair it. For replacement information see warranty in Owner’s Manual.
5. Smoke alarms have technical limitations and may not respond in all situations. FIRE PREVENTION is your best safeguard.

### Further Information

Please read the information provided by the manufacturer, which is included in your Motor Home Operations Manual binder. It includes information on precautions, operational testing, and battery/sensor replacement.

### FIRE EXTINGUISHER

A dry chemical fire extinguisher is located near the floor by the side entrance door.

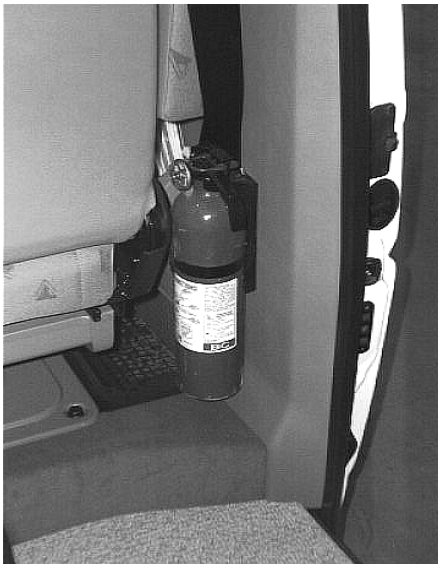

We recommend that you become thoroughly familiar with the operating instructions displayed on the side of the fire extinguisher or in the information supplied in your Motor Home Operations Manual binder.

We also recommend that you inspect the fire extinguisher for proper charge at least once a

month in accordance with National Fire Protection Association (NFPA) recommendations as stated on the label.

If the charge is insufficient, the fire extinguisher must be replaced.

### WARNING

Do not test the fire extinguisher by discharging it. Partial discharge can cause leakage of pressure or contents which would render the unit inoperative when needed. When using the fire extinguisher, aim the spray at the base of the fire.

### Rear Liftgate Exit

The rear liftgate may also be used as an exit. Remove the red plastic plug on the inner panel of the liftgate and lift the small latch mechanism to open the liftgate.

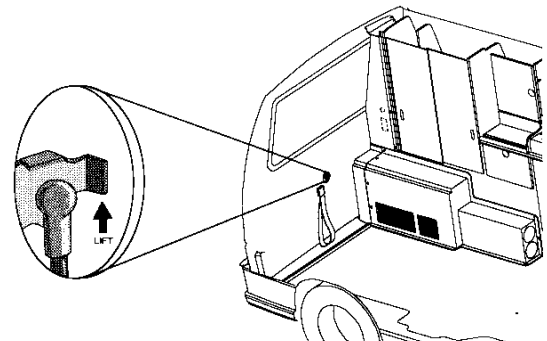



(See also Safety Precautions, Section 1 of this manual.)

### **LP GAS SUPPLY**

The LP gas system supplies fuel for the range, furnace and refrigerator (while in gas mode).

When used and handled properly, this system is safe and economical and provides modern living conveniences wherever you travel.

### **SAFE USE OF THE LP GAS SYSTEM**

The LP system is designed and built with strict adherence to both federal and recreational vehicle industry requirements for mobile LP gas equipment.

For your safety, there are many safety devices and backup systems installed, such as tank fill overflow valves, an interior LP gas detector/ alarm, and an interior carbon monoxide (CO) detector/alarm.

LP gas also contains an odor additive that you can smell if LP is present in the air.

Listed below are a few precautions to observe that will help you to use the LP gas system safely.

- Exercise caution at all times. Be familiar with the distinctive odor of LP gas. If a leak is suspected, turn off the supply valve immediately. Have the LP gas system checked by your dealer or a qualified LP gas service center.
- Do not tamper with the LP gas piping system, pressure regulator or gas appliances. Service and maintenance of LP gas system components should be performed only by your dealer or a qualified LP gas service center.
- Never attempt to connect natural gas to the LP gas system.
- Have the entire LP gas system inspected for possible leaks and missing or damaged parts at each tank filling. Also inspect before and after each trip, and any time trouble is suspected.

- Turn the LP supply valve off when not using the LP gas system.
- Never use a wrench to tighten the tank supply valve. It is designed to close leak-tight by hand. If a wrench is required to completely close the valve, it is defective and must be replaced.
- Never allow the tank to be filled above the 80 percent level indicated by the flow of liquid gas out of the overflow valve or by the automatic stop-fill device.
- Be sure appliance and outside vents are open and free from obstruction when using the LP gas system.
- Never attach a lock or any device requiring a key to the LP tank compartment door. According to standards set for recreation vehicles, the LP supply valve must be readily accessible in an emergency.
- Exercise caution when drilling holes or attaching objects to the walls. Gas lines and electrical wiring could be seriously damaged and present an extreme safety hazard.

### **HOW LP GAS WORKS**

LP (Liquefied Petroleum) gas is a true gas compressed into liquid form for easy transportation and storage. LP gas is available in two types - propane and butane. It is also called tank gas, bottle gas, or simply LP.

LP is used by appliances in vapor form only, but is stored in the tank as a liquid under very high pressure. As the liquid gas is released, it reverts back to a vapor and expands to many times its compressed volume.

### **SELECTING FUEL TYPES**

Butane burns hotter than propane, but will not develop a usable gas vapor at temperatures lower than 32° F. Propane, on the other hand, does not burn as hot but will convert to usable gas at temperatures down to -44° F. For this reason, pro-

pane is popular in cold climates, while butane and propane/butane mixtures are used most widely in milder climates.

*NOTE: Most LP dealers normally handle only the type of LP gas commonly used in their climate and area. If you anticipate filling your tank in one of the warmer states prior to traveling to a colder area, it is advisable to request propane only. Otherwise your LP system may fail to operate if the temperature drops below 32° F.*

Each gallon of liquid LP gas contains approximately 92,000 BTU's of heat energy; or about 36.2 cubic feet of dry gas for cooking, heating, water heating and refrigeration.

**LP TANK SYSTEM**

LP gas tanks are often listed in pounds rather than gallons. A gallon of LP gas weighs 4.24 pounds, so 20 pounds of LP equals about 4.6 gallons. Since LP tanks can only be filled to 80% of their total capacity, your 20-pound tank will actually hold 16 pounds, or about 3.7 gallons.

The LP gas tank is attached permanently to the frame of the vehicle and is only accessible from outside the vehicle. The tank controls have a rock shield to help protect them from damage during normal use.

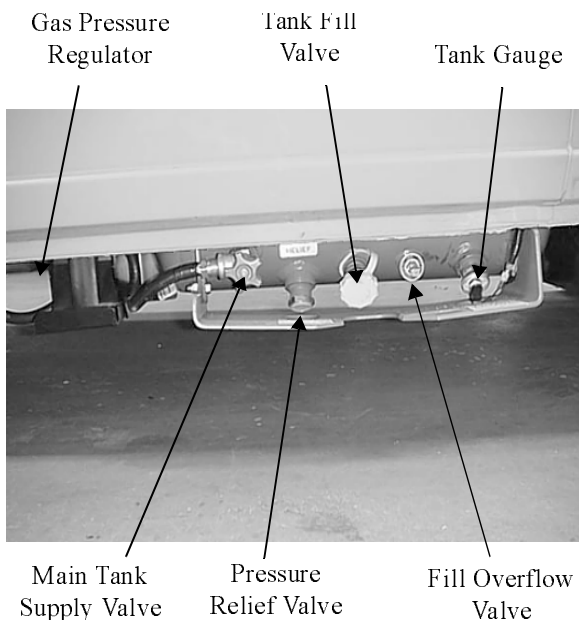

Before opening the supply valve, check to be sure all controls for gas appliances are in the "Off" or "Pilot Off" position. If this is not done, LP gas could build up inside the vehicle and create a fire or explosion hazard.

*NOTE: It is important to inspect the LP gas tank and fittings periodically for any damage that may have been received as a result of rough or uneven road conditions, road debris, driveway entrances, etc. If you notice any damage, take the vehicle to your dealer or an authorized LP gas service center for repairs.*

**LP Tank Capacity** .....(20 lbs./4.6 gals.)

**LP Tank Cover**

The LP gas tank controls are protected from road spray, debris and tampering by an aerodynamic plastic shroud. This cover must be removed for filling the tank or for turning the tank valve on or off.

To remove the cover, grasp one end and pry outward as shown until the retainer hole on the end of the cover clears the retainer bolt, then pull the cover outward and off.



To refit, place the retainer hole at one end of the cover onto the retainer bolt, then slide the other end over the other retainer bolt until it locks into the hole.

**REFILLING LP TANK**

Since the LP tank is permanently mounted to the frame, the motor home must be taken to an LP

dealership for filling. Do not attempt to remove the LP tank from the vehicle. There are many LP gas refueling stations located throughout the country. These stations are listed in the telephone directory Yellow Pages under "Gas - Liquefied Petroleum - Bottled and Bulk."

The tank is equipped with a fill adapter which allows easy filling with any LP filling equipment. The tank is full when liquid LP gas appears at the overflow valve.

*NOTE: The LP tank is equipped with an automatic 80% stop-fill device.*

### **AIR IN THE LP GAS TANK**

If your LP gas appliances do not stay lit or require frequent adjustment, even though you know the LP tank contains sufficient fuel, the problem may be air in the LP gas tank. Air in the tank mixes with the LP gas vapors causing them to burn poorly. This condition could linger for weeks if the air is not purged from the tank. Most LP gas dealers have equipment for purging air from LP gas tanks and will purge before refilling the tank.

### **TRAVEL WITH LP GAS**

It is illegal for vehicles equipped with LP tanks to travel on certain roadways or through certain tunnels in the U.S. To avoid inconvenience, check state regulations concerning flammable gas transportation.

### **WARNING**

**DO NOT FILL CONTAINER TO MORE THAN 80 PERCENT OF CAPACITY.** Make sure the motor home is level when filling. It is possible to accidentally overfill the tank if the vehicle is unlevel, with the fill valve on the uphill side. Overfilling the LP gas tank can result in uncontrolled gas flow, which can cause fire or explosion. A properly filled container will contain approximately 80 percent of its volume as liquid LP gas.

**All pilot lights must be extinguished** and supply valve closed before refilling LP gas tanks or vehicle fuel tanks.

**Do not smoke or expose an open flame** while near an LP refueling area. LP gas is heavier-than-air and extremely flammable.

**Never** fill the LP tank with the engine running.

**Never use an open flame** to test for LP gas leaks.

Replace all protective covers and caps on LP system after filling.

**Do not** alter or remove LP tank gauge at any time.

**WARNING**

Do not place LP gas containers, gasoline, or other flammable liquids inside the vehicle. LP gas containers are equipped with safety devices which relieve excessive pressure by discharging gas to the atmosphere. Fire or explosion may result.

**REGULATOR**

The pressure regulator is protected from the elements by a plastic cover which should be left in place at all times. Only your dealer or a qualified LP gas service should remove the regulator cover for adjustments.

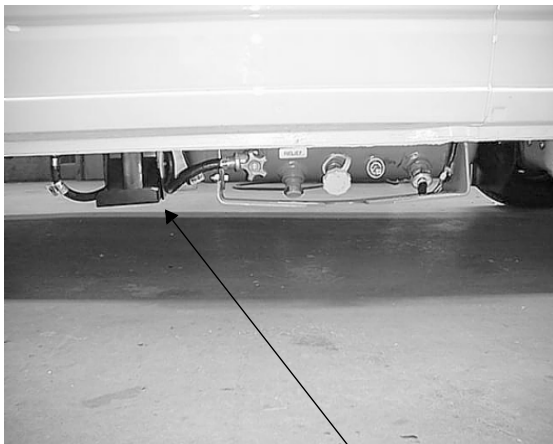

Gas Pressure Regulator

**WARNING**

Inspect the pressure regulator vent hole periodically for blockage. If any obstruction is apparent, have the regulator serviced by your dealer or a qualified LP gas service center.

LP gas regulators are installed with the diaphragm vent facing downward. Make sure that the regulator vent always faces downward to minimize vent obstruction which could result in excessive pressure, causing a fire or explosion.

through the cylinder valve and into the regulator where it can freeze. Fuel producers, tank and bottle manufacturers and LP gas dealers take every precaution to reduce moisture, but sometimes only a fraction of an ounce entering the tank can cause problems. To help avoid the possibility of freeze-up, always keep tank control valve closed when not in use, even when tank is empty, to prevent moisture from collecting on the inside.

If regulator freeze-up should occur, you may attempt to thaw the regulator using a light bulb. **DO NOT USE AN OPEN FLAME OR HEAT LAMP.**

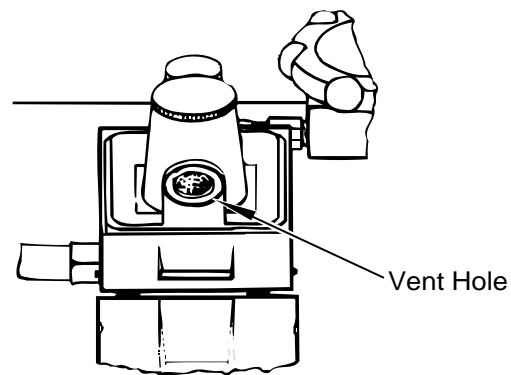

LPG PRESSURE REGULATOR  
(COVER OPEN)

If moisture begins to cause problems, have your LP gas dealer inject the proper amount of dry methyl alcohol in your tank to help guard against regulator freeze-ups.

In very cold weather when a large volume of gas is being used for heating, it is possible to experience a loss of gas pressure. At first, this problem may appear to be caused by a regulator freeze-up, but is actually caused by failure of the liquid gas to vaporize as fast as it is needed. As the temperature becomes colder, it is increasingly harder for the liquid LP gas to “boil-off” into a vapor. At the same time, the demand for LP to produce heat increases to the point where the system cannot maintain production.

The only solution to this problem is to reduce the consumption of gas where possible. Adjusting the temperature on the gas/electric refrigerator may be a first step.

Regulator freeze-ups are caused by the presence of moisture in fuel. This moisture will pass



**LP GAS LEAKS**

The following label has been placed in the vehicle near the range area. If you smell gas within the vehicle, quickly and carefully perform the procedures listed.

<b>IF YOU SMELL GAS</b>
<ol style="list-style-type: none"> <li>1. Extinguish any open flames, pilot lights and all smoking materials.</li> <li>2. Do not touch electrical switches.</li> <li>3. Shut off the gas supply at the tank valve(s) or gas supply connection.</li> <li>4. Open doors and other ventilating openings.</li> <li>5. Leave the area until odor clears.</li> <li>6. Have the gas system checked and leakage source corrected before using again.</li> </ol>

LP GAS ALARM - See page 1-3.

**WINTER USE OF LP GAS**

Due to vaporization characteristics of LP gas, it is important that the winter camper knows how to most efficiently use the LP system. The vaporization rate of LP gas decreases in a direct relationship to a decrease in temperature. As explained in the "Selecting Fuel Types" section, butane does not vaporize below 32° F, so propane must always be used in cold climates. However, even propane vaporizes at a slower rate as it becomes colder, especially below 0°F.

**How Long Will A Tank Last?**

Because LP gas vaporizes at varying rates at different temperatures and tank levels, and because we cannot predict how much you will use each appliance, it is impossible to compute exactly how long a full tank will last.

Listed below is a worst-case scenario and instructions on how to estimate your own LP gas usage.

To find out how long a tank should last, first remember from the "Selecting Fuel Types" section that LP contains about 92,000 BTU's of heat energy per gallon. Next you must compute the gas consumption (input BTU's) of the appliances in use. Your furnace has an input rating of 12,000 BTU's, the range burners are 6,500 BTU's each, and the refrigerator is 640 BTU's.

Let's say the weather is very cold and you need to run the furnace continuously. First divide 92,000 by 12,000 and you get 7.666. That's how many hours each gallon of LP should last. Multiply the 3.6 gallons in your full tank by the 7.666 hours per gallon, and you find that the full tank would last about 27 hours if the furnace were running continuously.

In reality, you would probably not be camping in temperatures that would require continuous use of the furnace. During moderate temperatures, with normal use of the range burners, refrigerator and furnace, a tank of LP would last considerably longer.

**LP Gas Usage Estimation Table:**

<p><b>Full tank gallons:</b> Tank size x 80% = Full gals. (wg)</p> <p>Example: 4.7 gal. x 80% = 3.6 gals. (useable)</p>
<p><b>Hours per gallon of LP:</b> BTU/gal. Appliance BTU input = Hrs./gal.</p> <p>Example: 92,000 ÷ 12,000 = 7.66666 (furnace) 92,000 ÷ 6,500 = 14.153 (range burner) 92,000 ÷ 640 = 143.75 (refrigerator)</p>
<p><b>Total duration of tank:</b> Gals. x Hrs./gal - Hrs. Duration</p> <p>Example (with continuous usage): Furnace: 3.6 (gals.) x 7.66666 = 27 hrs.</p> <p>Range: 3.6 (gals.) x 14.153 = 50.9 hrs.</p> <p>Refrigerator: 3.6 (gals.) x 143.75 = 517.5 hrs. (21 days)</p>



(See also Safety Precautions, Section 1 of this manual.)

Your camper is equipped with an electrical system consisting of two separate voltages: a 12-volt DC system and a 110-volt AC system. The 12-volt system consists of the auxiliary (coach) battery and the power converter. The 110-volt system is operated from an outside source by way of the utility power cord (shoreline). All systems operate through a single power converter control center to provide electrical power to the camper.

### 110-VOLT AC SYSTEM

The 110-Volt systems operates from an outside 110-volt utility service such as those at campgrounds. When the power cord is connected to an outside power source, the power converter automatically changes a portion of the 110-volt current to 12-volt DC current. Most equipment in the camper that is normally powered by the auxiliary battery is then powered through the converter.

The refrigerator, while running in AC mode, and any electrical equipment used at 110-volt convenience outlets are entirely dependent on an outside 110-volt AC source.

### EXTERNAL POWER CORD (Shoreline)

A 15-amp external utility power cord (commonly referred to as a “shoreline”) is required to provide electrical power to your camper.

#### WARNING

Do not connect the external power cord to any receptacle until you have contacted the owner and/or attendant of the premises to verify proper polarity and grounding.

It is the responsibility of the owner of the electrical receptacle to ensure that the receptacle is properly wired and grounded.

Reverse polarity and improper grounding of the vehicle can cause personal injury or death.

To connect to an external power source, connect the socket end of the power cord to the power input receptacle near the rear wheel on the driver side of the van. Plug the cord into a suitable 15 or 20-amp grounded (3-prong) power receptacle.

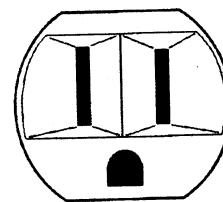

15-Amp  
Receptacle

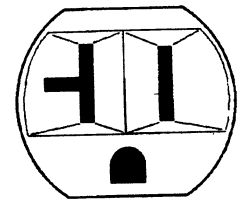

20-Amp  
Receptacle

If the shoreline becomes damaged and must be replaced, the replacement cord must meet the following specifications.

- rated at 15 amps.
- wire thickness at least 14 ga.
- no longer than 25 feet (to avoid unwanted voltage-drop)

### WARNING

**Do not** plug the power cord into an outlet which is not grounded, or adapt the plug to connect to a receptacle for which it is not designed.

Be sure that all three prongs of the supply cord are properly plugged into the receptacle.

**Do not** connect the power cord to an extension cord.

Most campgrounds are equipped with a fuse or circuit breaker at the receptacle. This protects the park's wiring, as well as the power cord on your vehicle, from electrical damage. If electrical power fails, contact the park attendants and have them check the fuse or breaker for your supply receptacle.

### 110-VOLT OUTLETS

A standard AC electrical outlet is provided in the galley for connecting small appliances such as radios and toasters, etc.

A second outlet is located at the rear hatch to accommodate your needs at the rear of the vehicle.

### 110-VOLT CIRCUIT BREAKER

The breaker panel protects all 110-volt components in the camper from either an overload on the circuit or a short in the wiring or component itself. When an overload or short develops, the 110-volt breaker will pop out, preventing any further flow of electricity and, therefore, damage to the system.

**To Reset Breaker:** Shut off electrical equipment and allow a brief cooling period. A couple of minutes is normally sufficient. Then reset the breaker by pressing the circuit breaker button firmly inward. If the breaker continually trips and no overload is evident, have the system checked for a short in the wiring or the appliance.

**To Disconnect Breaker:** If you need to disconnect the 110-volt circuit breaker, pull outward on the button.

### GROUND FAULT CIRCUIT INTERRUPTER

All 110-volt electrical circuits and outlets are connected to the GFCI (Ground Fault Circuit Interrupter), which is an extremely sensitive circuit breaker that will help protect you from severe electrical shock if a faulty electrical ground develops. The National Electrical Code has specified this device for your protection.

The shoreline cord must be connected to a fully grounded 15-amp or 20-amp 3-prong outlet to function.

If a faulty ground occurs, the GFCI will break the circuit and turn off power to all outlets and appliances. If this happens, unplug all portable appliances from outlets and press the reset button on the GFCI unit.

If the shoreline is properly connected and the GFCI keeps tripping, have your dealer check the electrical system and repair if necessary before using again.

The GFCI unit is located on the circuit breaker panel at the driver side rear of the vehicle just inside the liftgate.



Ground Fault  
Circuit Interrupter

**WARNING**

The GFCI will not completely eliminate electrical shock. Small children and persons with heart conditions or other disabilities which make them especially sensitive to electrical shock may still be injured by a 110-volt receptacles even though protected by a Ground Fault interrupter.

**POWER CONTROL CENTER (Converter)**

The 12-volt power center is located in the rear of the vehicle, inside the lower part of the cabinet. The only visible part of the power center is the breaker panel at the bottom rear cabinet area inside the liftgate.

When the shoreline is connected to the camper, the 110-volt AC electrical current goes directly into the electronic Power Center. Inside the Power Center, the power converter routes part of the electricity directly to 110-volt circuits (outlets, lights, refrigerator AC mode, etc.) and the rest is changed to 12-volt DC and routed to the 12-volt lights, LP gas alarm and furnace.

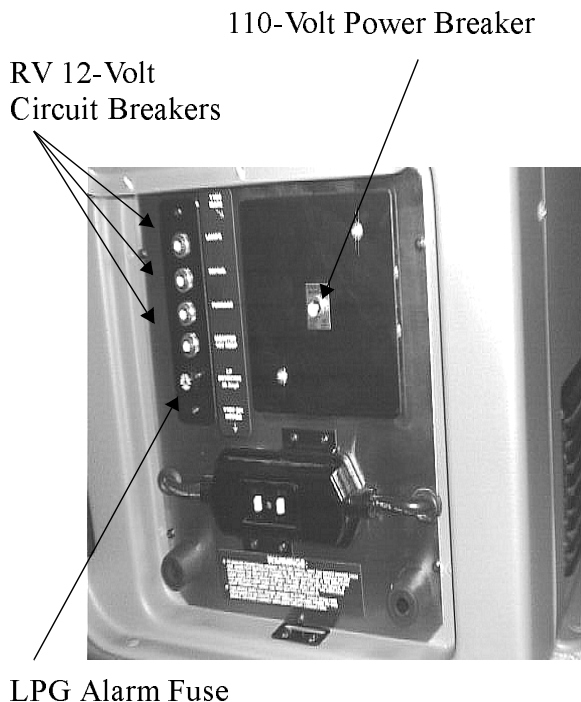

**RV POWER CENTER**

**THERMAL BREAKER**

A protective thermal breaker will “break” the 110-volt AC power to the 12-volt power converter section of the Power Center if the power converter becomes overheated. This can result from operating above its maximum limit for an extended period of time or by obstruction of ventilation to unit.

*NOTE: Power converter section will automatically route 12-volt lights and motors to battery power in this event.*

The thermal breaker will reset itself after a period of time, and the lights and motors will again resume operation from power converter section. If the breaker trips again shortly after reset, take immediate steps to correct cause of overheating. A portion of RV 12-volt load (lights or motors or both) should be turned off to reduce total load. Also, inspect power converter section to make certain ventilation is not obstructed.

**POWER CONVERTER CHARGING SECTION**

The converter in this vehicle has a special electronic charger section which also charges the coach battery while the shoreline is plugged into a 110-volt source. The electronic charger constantly monitors and adjusts the rate of charge so the battery is not undercharged or overcharged - the two major causes of battery deterioration and failure.

If the coach battery has been extremely discharged, it will accept charge at a relatively high amperage rate. If it is only slightly discharged, it will charge at a lower amperage rate. The rate of charge will decrease as the battery reaches “full charge”. Active charging will not resume until the battery again falls below “full charge”. The converter will not overcharge the battery. If your storage battery does not charge as described above, it is possible the battery is defective.

**IMPORTANT**

The converter will not change 12-volt DC current to 110-volt AC.

## **12-VOLT DC SYSTEM**

### **AUTOMOTIVE BATTERY**

The automotive battery is located under the hood. It operates the engine starter and all automotive accessories and controls found on the instrument panel. This includes the horn, power windows and locks, all exterior lights, radio, windshield wipers, in-dash heater fan, etc.

### **AUXILIARY (COACH) BATTERY**

The coach battery is a “deep-cycle” type battery specially designed for recreational vehicle use. It will provide longer lasting power than a standard automotive battery, and it will withstand the frequent drain-and-recharge cycles that occur under the demanding conditions of a camping outing.

The coach battery supplies current to the LP gas alarm, interior lights\*, refrigerator, furnace fan, water pump and water level and holding tank gauges.

The coach battery is automatically charged by the engine alternator while engine is running and by the power converter when the shoreline is connected to an external source.

\*Exceptions are the cab “dome” light and sliding door light, which are connected to the automotive (starting) battery.

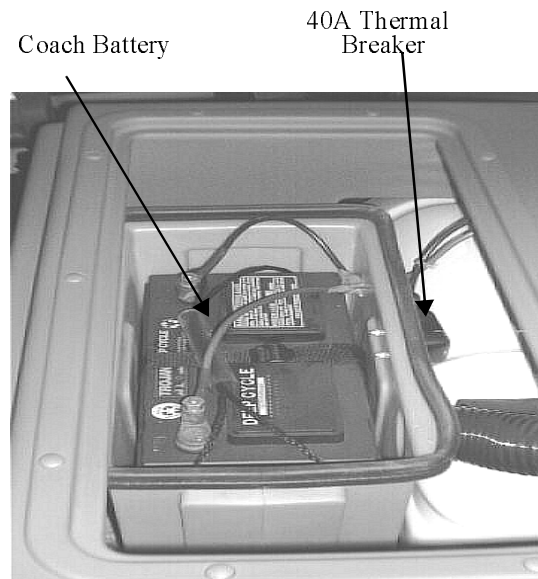

### **12-VOLT OUTLETS**

A 12-volt electrical outlet (cigarette lighter-type socket) is provided in the galley for connecting small 12-volt electrical devices, such as a travel iron or coffee pot, etc.

A second outlet is located near the rear hatch to accommodate your needs at the rear of the vehicle.

### **12-VOLT CIRCUIT BREAKERS**

All 12-volt RV circuits and equipment in the camper are protected by a circuit breaker panel. When a circuit is overloaded or a short develops in any part of the system, a breaker will shut down that circuit. If this happens, turn off all affected lights or appliances and reset the breaker.

A label on the panel states the amperage rating and circuit protected for each breaker.

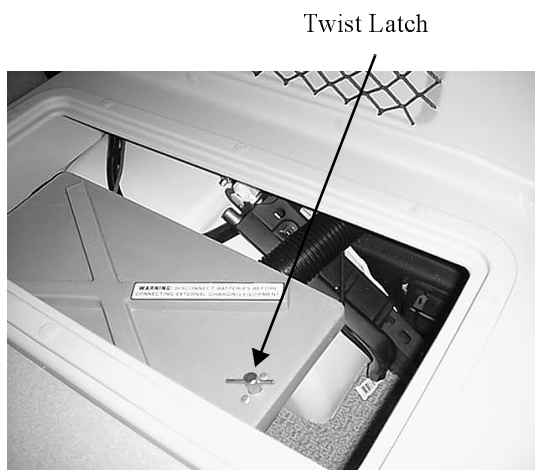

Coach Battery Box in Right Rear  
of Vehicle

12-Volt Breakers

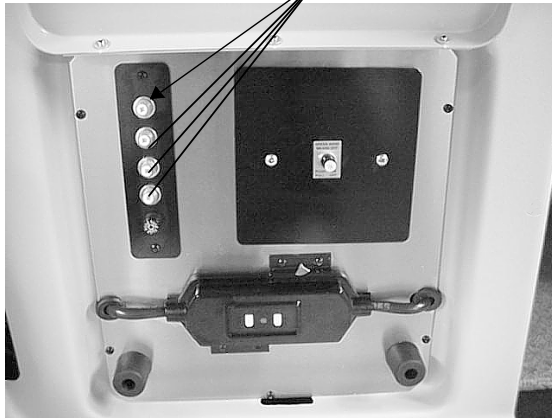

### COACH BATTERY CIRCUIT BREAKERS

The main connection from the auxiliary battery to the RV electrical power center contains a 40-amp self-resetting (thermal) circuit breaker. The circuit breaker is located on the battery main wire inside the auxiliary battery/storage compartment. (See photo on page 3-4.)

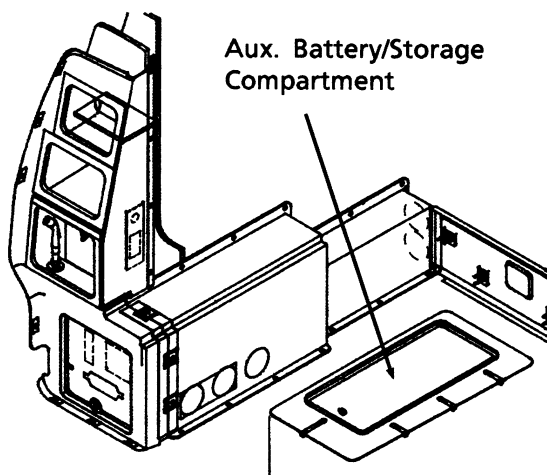

If none of the 12-volt RV electrical equipment is working, including the power center, check this fuse. If the breaker trips, never replace the breaker with one of higher amperage rating.

If the breaker continually trips, there may be a short circuit or other electrical malfunction that must be diagnosed and corrected by your dealer.

### BATTERY STORAGE AND MAINTENANCE

Lead-acid type batteries are electro-chemical devices for storing and releasing electrical charge. As such, they are simply an electrical reservoir, not an electrical source. As soon as energy is removed from the battery, it should get replaced by the engine alternator or the RV converter system.

If a battery sits unused for 30 days or more, especially during warm weather, it can develop a deposit of sulfate crystals on the metal plates inside the battery. This condition is called “sulfation” or “sulfating”, and prevents the battery from either releasing or accepting a charge. If this happens, the battery must be replaced.

If a battery does not contain at least 80% charge during freezing temperatures, the electrolyte can freeze and crack the battery case.

The two best defenses against sulfation and under-charge are:

1. Disconnect the battery cables to avoid any “parasitic” discharge, and
2. Check the battery and recharge as necessary at least once a month during long periods of storage.

As a further precaution, remove the battery from the vehicle and store it in a cool location on a wooden or rubber pad. Checking charge periodically to avoid discharge or sulfation.

### BATTERY MAINTENANCE

To ensure that the battery will always accept and hold a charge, some minor maintenance practices should be followed:

- Make sure the battery always remains securely clamped in the battery box and the cable clamps are tight on the terminal posts and free of corrosion.
- Remove and neutralize any corrosion buildup on the battery by brushing with a solution of baking soda and water, and then rinsing with clear water. The water will drain through the bottom of the compartment. Rinse the inside of the battery box with clean water also after rinsing the battery.

*NOTE: Make sure vent caps are on securely to prevent baking soda solution from entering the battery and contaminating electrolyte fluid.*

1. The automotive engine must be stopped.
2. An interior light should be turned on to provide a small load which draws off battery surface charge.

**WARNING**

Before removing any battery cables or battery, make sure all 12-volt equipment in the vehicle is off and the power cord has been disconnected.

Always remove jewelry and wear protective clothing and eye covering when checking or handling batteries.

- Clean and tighten battery terminals and have the specific gravity checked at least once a year.
- Every two months, or more often in hot weather, check the battery fluid level. Fill to approximately 3/8 inch above the plates. **DO NOT OVERFILL.**
- If water is added during freezing weather, the vehicle should be driven several miles to mix water and electrolyte to prevent freezing.

**WARNING**

To prevent wiring damage, it is essential when replacing the cables on the battery, or when using a “booster” battery, that the positive post and the positive cable be attached and the negative post and negative cable be attached. The posts are marked (+) plus and (-) minus. If a “fast charger” is used while battery is in the camper, disconnect both battery cables before connecting the charger. Never attempt to charge or boost a frozen battery.

**BATTERY CONDITION METER**

This meter allows you to check the level of charge in the coach battery in your camper. It is located on the monitor panel in the galley area. (See Section 5-5.)

To obtain an accurate reading:



Your camper is equipped with a 12-gallon fresh water tank and a 8-gallon waste water holding tank. A 12-volt water pump supplies fresh water to the galley sink faucet and the rear convenience sprayer. The pump is regulated to a flow rate of 1/2 gallon per minute to help avoid using up the fresh water supply too quickly.

### **GALLEY SINK FAUCET**

The galley faucet is a versatile European design that allows a greater range of motion than traditional domestic faucets. Rather than swiveling sideways, the faucet arm swings upward or downward, and the nozzle rotates a full 360°, allowing the water to reach any corner of the sink.



#### **Operation**

The water pump turns on automatically when the faucet knob is opened. When the faucet knob is closed, the pump turns off.



*NOTE: The faucet arm does not swivel side-to-side as domestic faucets do. The arm swivels up and down, while the nozzle end rotates from side to side. The faucet arm may break if attempted to swivel sideways.*

### **REAR SPRAYER**

The convenient spray head can be used to rinse soiled items off outside the camper. The spray head will work only when the pump switch is on. A pump switch is located on the panel right behind the sprayer head. Turn the switch off as soon as you are done using the sprayer. Do not let the pump run for a long period of time with the sprayer off.

Water Pump  
Switch



### **FILLING FRESH WATER TANK**

#### **Capacity: 12 gal.**

The water fill is located on the left (driver) side rear panel inside the liftgate. The water fill is located on the left (driver) side rear panel inside the liftgate. Stick your finger inside the finger hole on the water door and pull to open the water fill door. Press door shut until you feel the “click” to close.

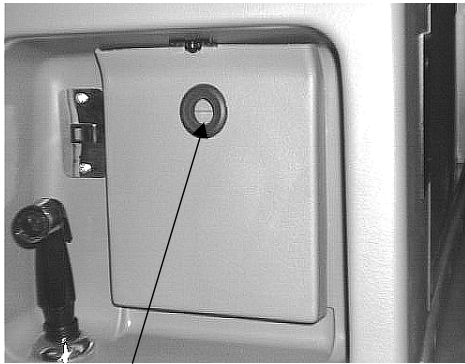

Finger Hole

**Fresh Water Fill Door**

There is also a remote water pump switch in this area for your convenience. Push the top of the switch to turn the pump on; push the button of the switch to turn the pump off.

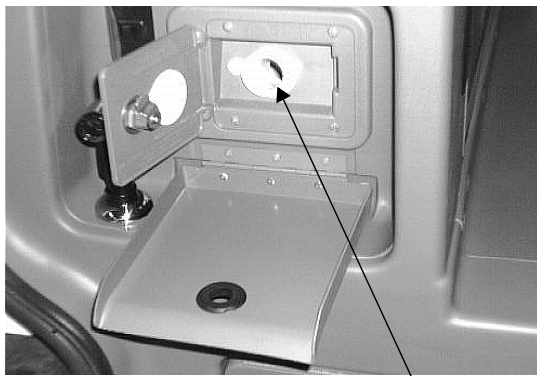

Fresh Water  
Tank Fill

**INSTRUCTIONS FOR DISINFEC-  
TION OF FRESH WATER SYSTEMS  
ON RECREATION VEHICLES**

(As approved by the U.S. Public Health Service)

To assure complete disinfection of your fresh water system, it is recommended that the following procedure be followed on a new system, one that has not been used for a period of time, or one that may have become contaminated. This procedure is also recommended before long periods of storage such as over winter.

1. Prepare a chlorine solution using 1 gallon of water and 1/4 cup of household bleach (sodium hypochlorite solution). With tank empty, pour chlorine solution into the tank.

Use 1 gallon solution for each 15 gallons of tank capacity. This procedure will result in a residual chlorine concentration of 50 ppm in the water system. If a 100 ppm concentration is required as discussed in item 3, use 1/2 cup of household bleach with 1 gallon of water to prepare the chlorine solution. One gallon of the solution should be used for each 15 gallons of tank capacity.

2. Complete filling of tank with fresh water. Open each faucet and run the water until a distinct odor of chlorine can be detected in the water discharged.
3. Allow the system to stand at least 4 hours when disinfecting with 50 ppm residual chlorine. If a shorter time period is desired, then a 100 ppm chlorine concentration should be permitted to stand in the system for at least 1 hour.
4. Drain and flush with fresh water.

**WARNING**

Chlorine is poisonous - recap bottle and clean utensils after use.

Never use automotive type antifreeze in your potable water system as it is poisonous.

**WATER DRAIN VALVE**

The water drain valve is used to drain water from the water tank and the water supply lines when preparing the camper for freezing temperatures or when sanitizing the water system.

The water drain valve is located at the floor inside the lower storage cabinet to the left/rear of the refrigerator.



Water Line  
Drain Valve

*NOTE: The photo shows a cutaway view of the water pump location for illustration purposes only. The pump is not normally visible. To gain access to the pump, remove the screws holding the cabinet back panel to the wall.*

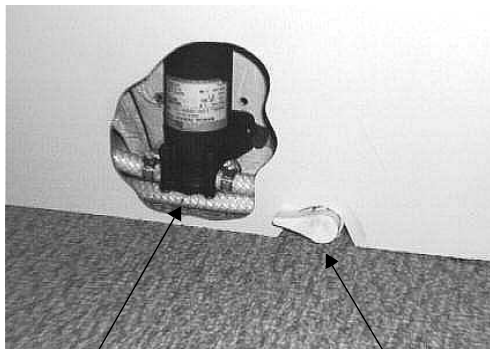

Water Pump

Drain  
Valve

To drain the tank and lines, turn the drain valve handle clockwise fully, then open the galley faucet to turn on the water pump. This will “power drain” the tank and lines. (Some water will be pumped into the sink and drain into the gray water holding tank, which must be drained after this procedure is done.)

The water will drain onto the ground from a tube through the floor of the vehicle. The drain tube is located on the underside of the vehicle, near the middle just ahead of the rear axle.

When the water tank and lines are finished

draining, close the galley faucet or turn the water pump switch off, then turn the drain valve handle counter-clockwise fully to close.

## WASTE WATER HOLDING TANK

**Capacity: 8 gals.**

The waste water holding tank and dump valve are located beneath the driver side of the vehicle, near the rear tire.



## DUMPING HOLDING TANK

1. Remove dust cap from drain and connect drain hose. Be sure it is firmly attached.
2. Place the other end of drain hose into disposal opening.

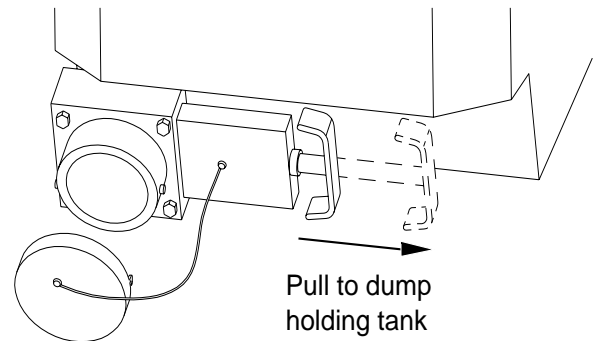

Waste Water Dump Valve

3. Open valve with a quick pull. Make sure there are no sags in the hose during drainage.

Close valve handle as soon as tank is empty and replace dust cap securely.

4. Rinse drain hose thoroughly with water.

*NOTE: We recommend that you dump holding tank before traveling to avoid carrying unnecessary weight.*

## **HOLDING TANK LEVEL INDICATORS**

You can check the levels of the waste water holding tank and the fresh water tank using the monitor panel on the front face of the galley cabinet.



Press the switch labeled “Levels Test” to show the levels in all tanks.

See page 5-5 for further information on the monitor panel.

Your EuroVan Camper has many convenient, self-contained RV features.

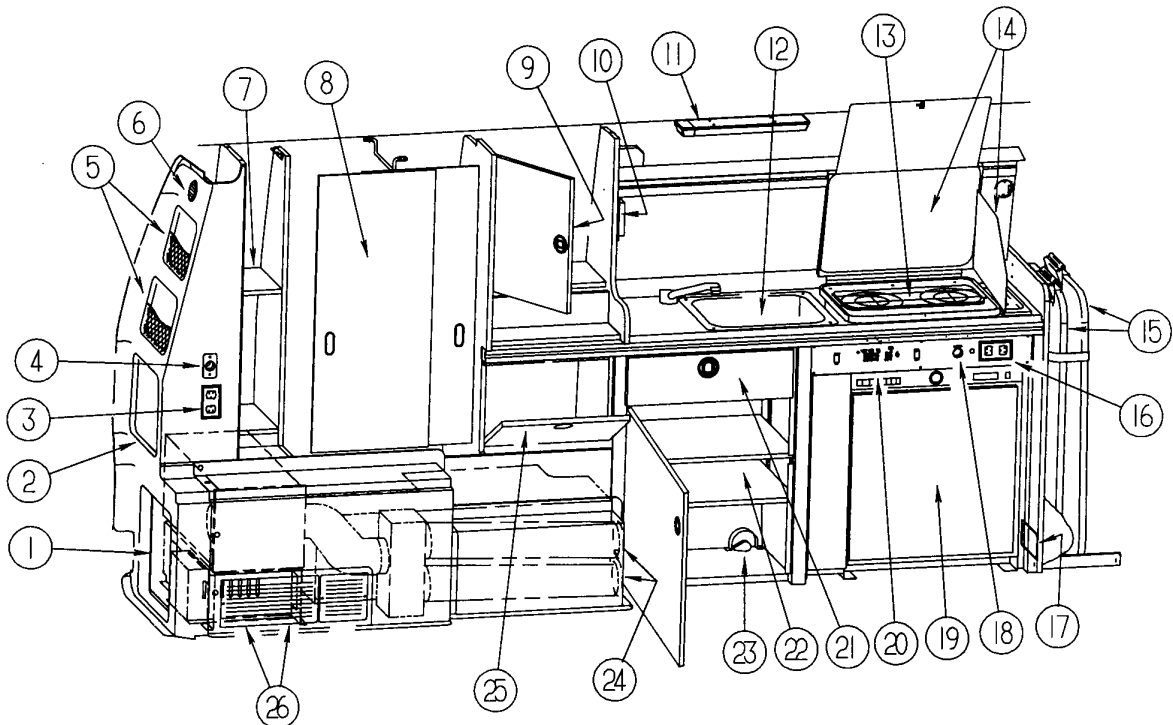

**\*\*CAUTION:** Be careful. These features may become HOT while refrigerator or furnace are in use.

- |                                   |                                    |
|-----------------------------------|------------------------------------|
| 1. Camper Electrical Power Center | 14. Range Burner Spatter Shields   |
| 2. Water Center                   | 15. Table Storage                  |
| 3. 110-Volt AC Outlet             | 16. 110-Volt AC Outlet             |
| 4. 12-Volt DC Outlet              | 17. LP Gas Alarm                   |
| 5. Storage Pockets                | 18. 12-Volt DC Outlet              |
| 6. Cold Air Return Grille         | 19. Refrigerator - AC/DC/Gas       |
| 7. Storage Shelves                | 20. System Monitor Panel           |
| 8. Wardrobe/Storage Closet        | 21. Utensil Drawer                 |
| 9. Storage Cabinet                | 22. Storage Cabinet                |
| 10. Furnace Thermostat            | 23. Water Line Drain               |
| 11. Fluorescent Light             | 24. Furnace Heat Vents             |
| 12. Galley Sink & Faucet          | 25. Storage Cabinet                |
| 13. LP Gas Range Top              | 26. Furnace Cold Air Return Grille |

\*Water pump located behind back panel. Remove screws to access.

(See also Safety Precautions, Section 1 of this manual.)

*NOTE: Some items described in this section may be optional and may not apply to your vehicle.*

The appliances installed in your camper are manufactured by reputable RV appliance makers and have been tested by independent laboratories to meet all applicable standards and codes set for RV appliances. These appliances are covered by your New Vehicle Limited Warranty. (Certain items may have extended coverage under the individual manufacturer's warranty.) See your New Vehicle Limited Warranty for details.

### REFRIGERATOR (2 Cu. Ft. 3-Way Powered)

The refrigerator in your camper can be operated from any one of the three power sources available to your vehicle:

- 110-Volt AC Electric
- 12-Volt DC Electric
- LP Gas

*NOTE: The 12-volt operating mode is the least efficient method and should be used only to "hold" the cold while traveling (not for initial cool-down or temperature maintenance). Always use either the 110-Volt AC or LP Gas operating modes while parked or for pre-cooling refrigerator before use.*

*The 12-volt mode operates continuously (not thermostatic) and will discharge the auxiliary battery rapidly if left on without the van engine running to recharge it. The power converter cannot replace the auxiliary battery charge at the same rate that the refrigerator consumes it.*

### LEVELING

Always park the vehicle on a level location when operating the refrigerator.

Normal vehicle leveling to provide comfort for the occupants is satisfactory for refrigerator

operation. This will be well within the operation limits of 6° side to side and 3° incline front to back.

### CAUTION

To prevent permanent damage to the refrigerator cooling unit, turn the refrigerator off if the vehicle will be parked on an incline of over 6° side-to-side or 3° front-to-back (such as steep driveways or parking lots, etc.) for more than one hour.

### OPERATING INSTRUCTIONS - NORCOLD 3163

The refrigerator controls are located at the top front of the refrigerator.

The Lighting and Start-up Instructions are located on the top portion of the interior door liner.

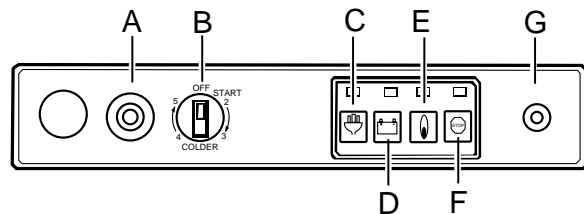

### Gas Operation

1. Set thermostat (B) to the start setting.
2. Place the mode selector button (E) to the gas position. Ignition spark will be present at the burner.
3. Push and hold the safety valve button (A) until the indicator lamp (G) glows steady. Continue to hold the safety valve button in for 15 seconds and then release. The indicator lamp should remain a steady glow. If the lamp turns off, repeat this step.

**NOTICE:** On initial start-up, it may take longer for the burner to light because of air being purged from the gas supply line.

**WARNING**

Do not hold gas valve in more than 30 seconds. If the flame is not indicated within this time, turn the gas at the selector switch (F) off, and wait 2 minutes and retry. Continuing to hold the gas valve in will cause gas to build up in the burner area and can result in an explosion which can cause personal injury or property damage.

4. Set thermostat (B) to desired temperature setting.

**AC Operation**

1. Place the mode selection button (C) to the AC position.
2. Set the thermostat (B) to the coldest (maximum) setting. Allow to operate at maximum setting for 6 to 8 hours before setting to mid range.

**DC Operation**

1. Place the mode selection button (D) to the DC position. There is no need to set thermostat to any setting. The DC operation is a continuous run (no thermostat control) mode.

**SHUT-DOWN: ALL MODES**

1. Place the mode selector button to the off position. This will interrupt all AC and DC power and stop operation of the refrigerator.

**OPERATING TIPS**

- The refrigerator should already be cold before placing items in it.
- Food and beverages should also be cold before placing in RV refrigerator. Never put warm or hot items in a cold refrigerator.
- Do not pack the refrigerator too full. The refrigerator needs room for cold air to circulate.
- Use smaller containers for each item. (e.g. a half gallon container of milk instead of a half-full gallon jug)

- Always put foods, especially liquids, in tightly sealed containers.
- Used crumpled paper between loose items to reduce rattling or “clinking” noises.

**FOR FURTHER INFORMATION**

See the Norcold operating instructions provided in your Owner Information binder for further information, including precautions and periodic maintenance.

**RANGE TOP**

The range top in your motor home operates on LP gas and will provide nearly all of the functions that the range in your home does

The following warning label has been located in the cooking area to remind you to provide an adequate supply of fresh air for combustion.

**WARNING**

IT IS NOT SAFE TO USE COOKING APPLIANCES FOR COMFORT HEATING.

COOKING APPLIANCES NEED FRESH AIR FOR SAFE OPERATION.  
BEFORE OPERATION:  
1. OPEN OVERHEAD VENT OR TURN ON EXHAUST FAN AND;  
2. OPEN WINDOW.

Unlike large homes, the oxygen supply inside a recreational vehicle is limited due to its size. To avoid danger or asphyxiation, provide proper ventilation when using the gas rangetop. It is especially important that the gas range top not be used for comfort heating. Danger of asphyxiation is greater when these appliances are used for long periods of time.

**WARNING**

Portable fuel-burning equipment, including wood and charcoal grills and stoves, shall not be used inside the recreational vehicle. The use of this equipment inside the recreational vehicle may cause fires or asphyxiation. Do not operate the range top with the center seat in place.

**Range Burner Heat/Spatter Shield**

A folding spatter shield is built into the underside of the range top cover to meet safety requirements for cooking appliances. When deployed, the shield helps to protect the roof edge above the stove and the back of the driver's seat from spatters and excessive heat.

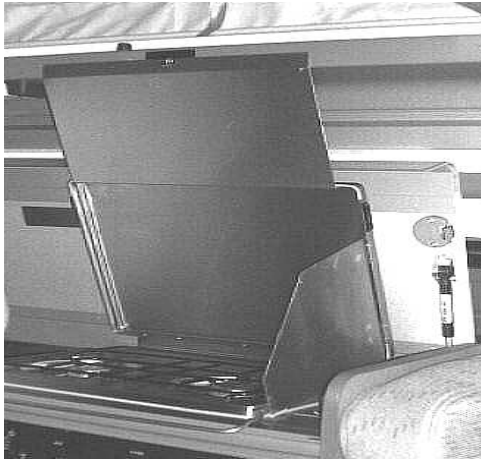

Spatter Shield

A spring-loaded retainer ring is located on the roof edge above the stove to hold the upper shield in place during use.

Spatter Shield Retainer Ring

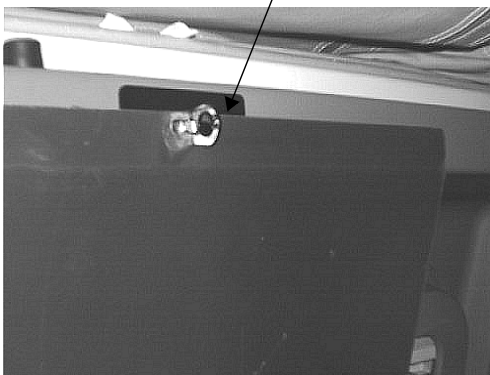

To fasten the upper shield, position the slot in the shield over the retainer ring, pull the ring outward and turn to a vertical position.

**Using Top Burners**

1. Light match and hold to burner.
2. Slowly turn burner knob (counterclockwise) to the "ON" position.

3. When the burner lights, extinguish match and adjust the flame height by turning the knob toward the "OFF" position.

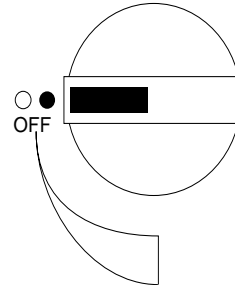

**WARNING**  
 Do not turn burner control knob to "On" and allow gas to escape before lighting match.

**MONITOR PANEL**

The monitor panel is located on the front face of the galley cabinet. Push the "Levels Test" button to simultaneously display the coach battery condition and levels of the water tank, holding tank and LP tank.

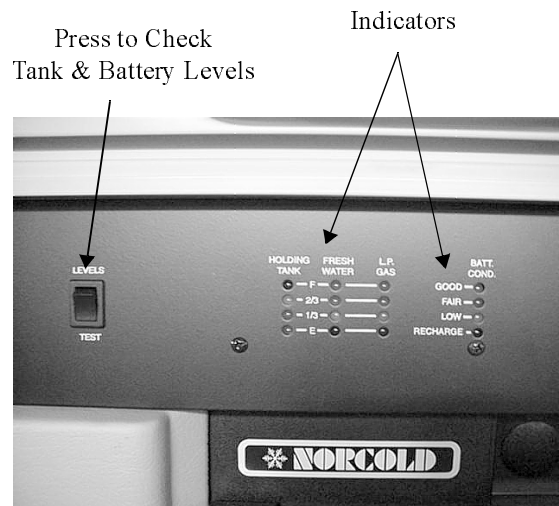

Monitor Panel

**WATER AND HOLDING TANK LEVELS**

Press and hold the "Levels Test" switch to show approximate level on the monitor lights.



Approximate levels of the fresh water and holding tank are measured by sets of electronic probes in the sides of the tanks. The liquid must be at or above a probe to illuminate the indicator lights to a given level.

For example, a water level of 1-2" above the 1/3 probe would register as only 1/3 full. Consequently, a level of merely 1" below the 1/3 probe would register empty. Generally speaking, there is actually more liquid in a tank than indicated.

### LP GAS LEVEL

Press and hold the "Levels Test" switch to show approximate LP tank level.

The LP level is registered by a sending unit on the tank. The gauge mounted on the side of the tank will give a more accurate indication of actual tank level if needed.

### BATTERY CONDITION METER

Push the "Levels Test" button to check the level of charge (voltage) in the 12-volt coach battery. The colored segments (red, yellow and green) will light from the bottom up to the amount of charge the battery contains.

- Green - good or adequate charge.
- Yellow - marginal charge.
- Red - battery needs charging before use.

### LP GAS FURNACE (SUBURBAN)

#### START-UP:

1. Open the LP gas tank valve by turning fully counterclockwise.
2. Move thermostat temperature selector from OFF position and place to desired temperature.
3. Furnace fan will start to blow immediately after setting thermostat.
4. After about 30 seconds, the furnace burner will light.
5. The furnace will now cycle off and on automatically as the thermostat demands just like a household furnace.

*NOTE: If heat does not come out of the heat ducts after a minute or so the burner is not lit. Turn thermostat off for 3-5 min-*

*utes, check to be sure tank valve is open and tank is not out of fuel, then try steps 2-4 again. If it still will not light after three attempts, contact your dealer or a local RV service center.*

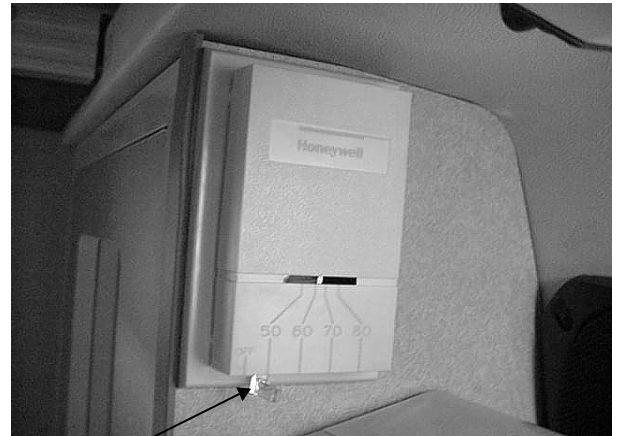

Thermostat Selector

### CAUTION

Do not block the ventilation louvers in the rear "aisle" of the camper. These vent louvers provide cold air return to the furnace. Obstruction could cause the furnace to operate inefficiently.

#### SHUT-DOWN:

1. Turn thermostat switch "OFF".
2. Close LP tank valve completely.

#### For Further Information

Please see the Suburban furnace operating instructions provided in your Owner Information binder for further information, including additional operating precautions and periodic maintenance.

### HUMIDITY AND CONDENSATION

Moisture condensing on the inside of windows is a visible indication that there is too much humidity inside the camper. Excessive moisture can cause water stains or mildew which can damage interior items such as upholstery

and cabinets. To help reduce excessive moisture inside the camper, partially open a window, roof vent or pop-up roof flap.

### **POP-UP ROOF**

The pop-up roof feature provides extra headroom for standing and space for sleeping while keeping you out of the elements. The hard-shell top and vertical canvas sides provide weather resistance that is superior to tents. It can also be quickly and easily lowered in event of severe weather.

#### **WARNING**

Do not release pop-up roof latches or raise roof while the vehicle is moving.

### **Raising**

The pop-up roof retainer latches are the gold colored metal paddles recessed into the cab header molding above the front seats.

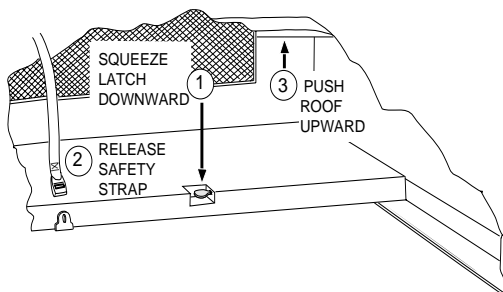

1. Squeeze the latch paddles downward to release the roof latches.

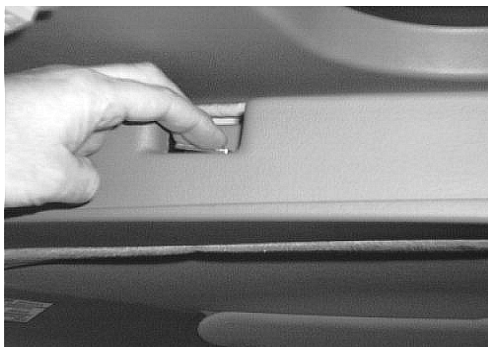

2. Unbuckle the pop-up safety strap at the front center of the cab header.



3. Push the roof upward until fully raised with canvas sides stretched.

### **Lowering**

1. Be sure the upper bed is in the user position (unfolded and flat) before trying to lower roof.
2. Pull downward evenly on handles on inside of roof. Pull the roof down far enough to buckle the safety strap. Then push the roof back up until it is partially open and the strap is tight.
3. Be sure canvas sides are tucked into space around edge of inside roof opening and not protruding out side of roof when closed.
4. Pull downward firmly on roof handles one at a time until each latch locks with two distinct "clicks".

#### **CAUTION**

Never store the canvas wet for extended periods because mold and mildew can form and destroy the material. If the roof must be lowered while the canvas is wet, raise the roof again as soon as possible to allow the canvas to dry.

**SLEEPING FACILITIES****WARNING**

Do not use sleeping facilities while vehicle is moving.

**UPPER BED**

The upper bed is located in the pop-up roof section of the camper. It provides sleeping capacity for 2 persons (up to 400 lbs. total).

**To Use Upper Bed:**

1. Unfold the hinged bed board forward into position onto the support tracks in the roof opening.
2. Place mattress cushions onto bed board and press hook-and-loop fasteners together.

**To Store Upper Bed:**

The bed can be stored two ways -

- Leave in the user position (flat) with cushions in place and lower the roof.
- ... or,
- Remove mattress cushions from vehicle and fold bed board out of the way completely to provide greater headroom for daily use. The bed board folds in a "Z" pattern as indicated on the following page.

*NOTE: When removing cushions from the vehicle, we recommend covering the cushions with plastic sheeting or bags while in storage to avoid soiling.*

**For More Headroom While the Roof is Up:**

The bed board can be folded partially, with mattress cushions in place, to provide greater headroom while the pop-up roof is raised.

- Fold the first and second sections together to stand upright as shown on following page. (Lift upward on the hinge between the first and second section while pushing the front edge of the first section toward the rear of the vehicle as shown, then push the front section back on the support rails until it contacts the second section.)



Lift hinge between 1st and 2nd sections.



- Remember to unfold bed board to flat position before lowering roof.

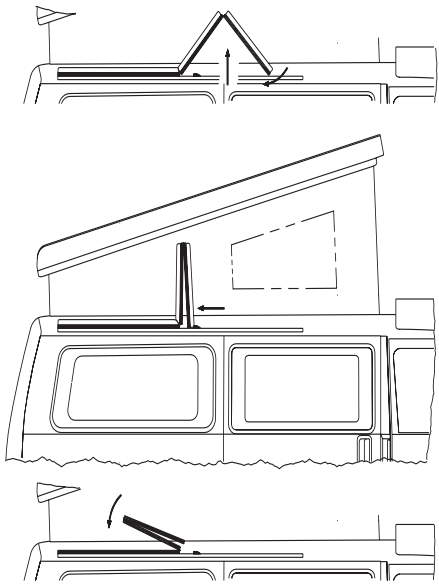

- Pull the seat all the way forward to the stop position and release the handle. Push the seat rearward slightly until the seat rails lock into position with a “click” on both sides.

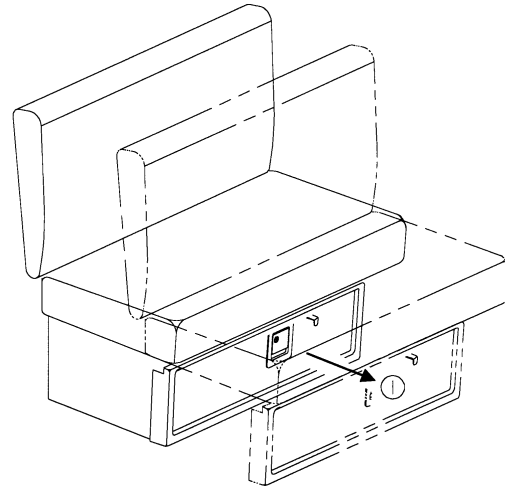

### REAR SEAT

The rear seat has many convenient features which give it a variety of purposes.

- Has 2 seating positions: 1) Normal seating position for travel, and 2) forward position for seating when using removable dinette table.
- Has storage space beneath cushion assembly.
- Removable front panel allows carrying long items, such as skis or lumber.
- Converts to 2-person bed.
- Can be unlatched and removed from vehicle for increased cargo carrying capacity.

#### To Slide Rear Seat Forward:

- Grasp the square latch handle on the front of the seat base and pull outward.



#### To Return Seat to Normal Position:

- Pull square latch on front of seat base outward.
- Push seat back to normal position until it locks into position on both sides.

#### Under-Seat Storage Compartment

A storage compartment is located beneath the rear seat cushion to stow items such as the headrests when converting the seat to a bed.

A prop rod is located under the passenger side of the seat cushion to help hold the seat up when accessing the storage compartment. Swing the prop assembly upward to hold the seat cushion up.

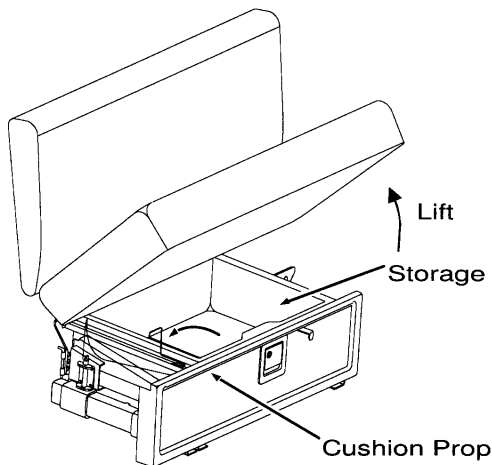

**To Remove Front Panel:**

The front panel of the seat may be removed to stow long items on the floor beneath the seat.

- The panel is held in place with C-shaped plastic clamps that grip the seat frame tubes.
- Grasp one end of the panel and pull outward gently and evenly until the panel is released.

**To Replace Panel onto Seat:**

- Place panel into position and press clamps firmly back onto seat frame tubes.

**To Convert Seat to Bed:**

*NOTE: Headrests must be removed before converting seat to bed. To remove, slide headrests upward and out of holes on top of seat.*

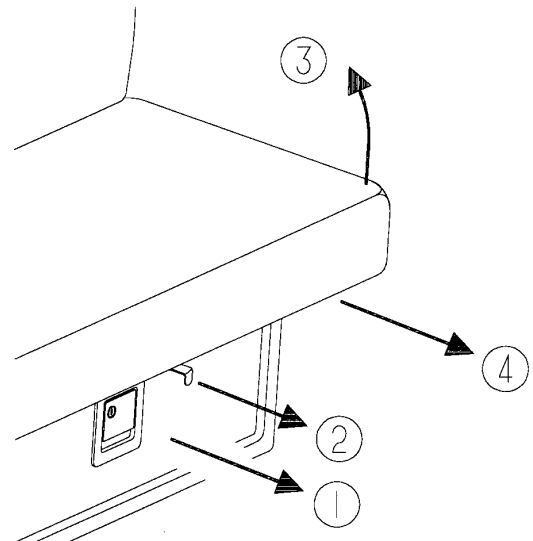

1. Grasp square handle on lower front of seat and pull seat base forward.
2. Pull seat latch forward and hold.



3. Lift seat cushion upward and release seat latch.
4. Pull seat cushion forward and lower back of seat into flat position.
5. Unfold mattress cushion and place over flattened seat to provide sleeping surface. Reverse procedure to convert bed back to seat.

**To Remove Rear Seat:**

The rear seat may be removed if more cargo capacity is required for carrying large items.

- A double-ended retainer strap is attached to the center rear of the seat. The end buckles attach to “tongues” bolted to the seat rails.

- Release the straps by pressing the release buttons in the center of the buckles.
- Slide the seat all the way forward, out of the slider assembly, and remove from the vehicle.

**To Reinstall Seat:**

- Be sure the seat is aligned straight to avoid damaging the slider assembly.
- Slide the seat all the way back into the slider assembly.
- Refasten the retainer straps. Do not twist straps.

**CENTER BENCH SEAT (Optional)**

The optional center bench seat provides extra seating capacity for daily use. It can also be removed or placed in the rear-facing position for alternate seating arrangements.

**WARNING**  
Do not operate the range top with the center seat in place.

**To Slide Seat Forward/Backward:**

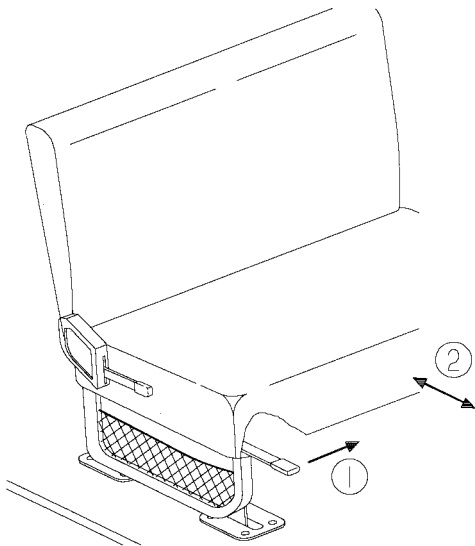

1. Push the slide release lever in toward the seat.
2. Slide the seat forward or rearward as desired. Release lever to lock seat into position.

**Reclining/Folding**

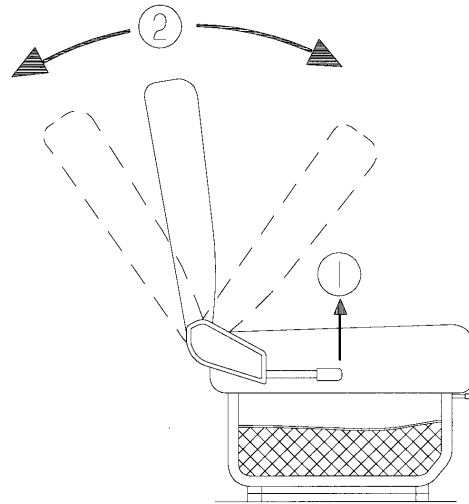

1. Lift side lever upward.
2. Recline or fold seat as desired. Release lever to lock seat in position.

**To Remove Center Seat:**

The center seat should be removed from the vehicle while camping to allow room for converting the rear seat to a bed. It is also much easier to raise and lower the pop-up top with the center seat removed.

*NOTE: Seat removal is accomplished best with two people.*

1. Pull the release levers out toward the middle of the seat. The release levers are the large black levers at the inside of the front legs on both sides of the seat.

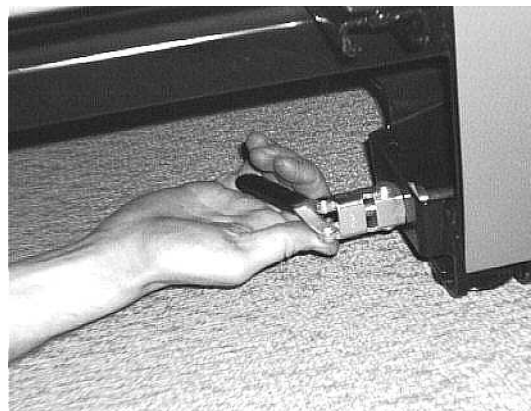

Pull levers outward to release seat.

2. Push the seat toward the rear of the vehicle until the leg bases clear the seat pegs in the floor of the van.

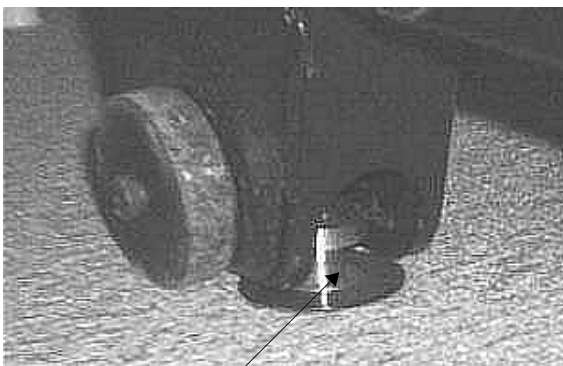

Floor peg exposed

3. Have another person help to lift the seat and remove from the vehicle or rotate and reinstall in rear facing position.
4. If the seat is removed from the vehicle, unscrew the seat pegs from the floor and screw in a flush mount plugs to prevent tripping on pegs when seat is not in place.
5. Reverse the above steps to reinstall seat in vehicle.

*NOTE: We recommend using two people to lift and remove the seat from the vehicle. To avoid damaging the vinyl floor covering, do not drag the seat across the floor when removing from the vehicle. After seat has been removed from vehicle, insert the threaded plugs into the floor sockets.*

### Child Restraint Tether Anchors

Most new child restraint (CR) seats for cars now offer safety tether straps to reduce injuries caused by forward movement of the CR seat. These tethers hook into ceiling-mounted anchor points located in the ceiling behind each rear seat.

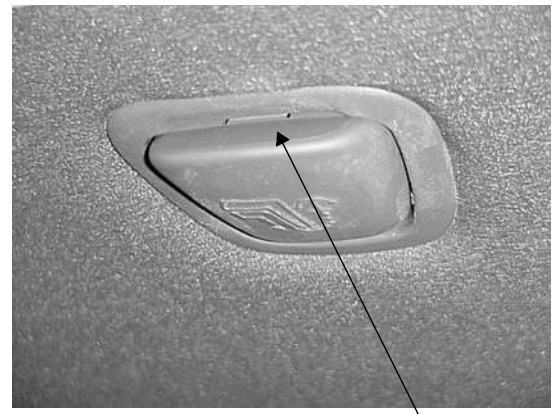

Pull front of cover down to access CR Tether Anchor

- Fasten the CR with seat belts as prescribed by manufacturer.
- Adjust the tether strap for proper length and tension. (See the CR manufacturer's information for specific instructions.)
- Pull the anchor cover down to access the anchorage loop.
- Hook the tether strap onto the loop shown.



Hook CR tether into Tether Anchor loop.

### CENTER COMPANION SEAT (Optional)

The center companion seat provides additional seating, yet allows full use of the refrigerator and galley while in position.

**Seat Adjustment** - See your Volkswagen EuroVan Owner's Manual for seat adjustment instructions.

**Seat Removal** - See instructions for Center Bench Seat removal. This seat uses the same latching mechanism as the center bench seat.

### TABLES

The removable tables are stored in a cradle at the front end of the galley cabinet.

To remove the tables from the cradle, release the belt catches by squeezing in on the sides of the buckle.

#### To Install Tables:

1. Hold table upright as shown, with the J-hook bracket at the bottom and the table top facing the galley. Insert the J-hook bracket into the rail at any point along the front of the galley cabinet as shown in the inset.

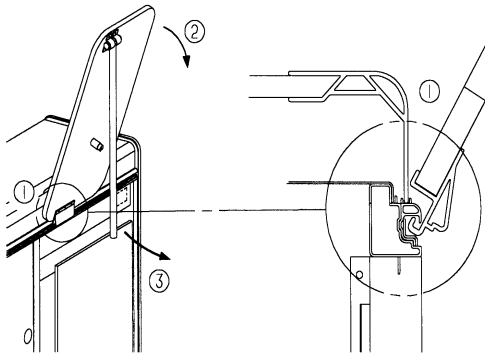

2. Swing the top end of the table down and away from the galley cabinet. This will engage the J-hook into the rail.
3. Swing the table leg downward to the floor.
4. Reverse these steps for removal.

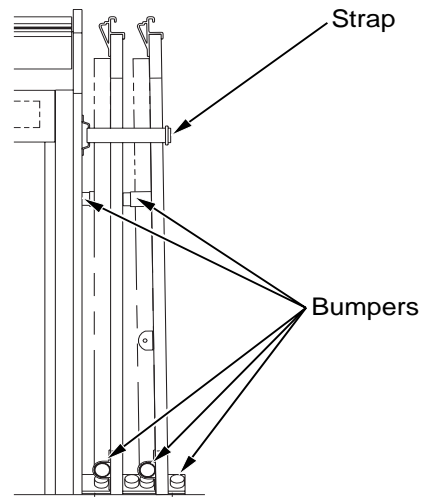

Table Storage Rack

*NOTE: When storing tables, be sure anti-rattle bumpers on table bottoms face toward end of galley cabinet and tables rest between bumpers in floor cradle.*

### INTERIOR LIGHTS

- Fluorescent lights are located beneath the pop-up roof opening on both sides of the vehicle.
- A 12-volt light is located on the ceiling of the pop-up roof. (The small lights over the side door and in the front cab area, as well as the cigarette lighter socket, are connected to the automotive 12-volt system.)
- A 12-volt light is located in the ceiling above the rear seat area. To turn the light on, press one side of the light lens and tilt as shown below. (It tilts both left and right). To turn the light off, press the protruding side of the light so the lens lies flat and flush with the ceiling.





### **SIDE TIP-OUT WINDOW**

The window on the galley side of the vehicle has a tip-out lower section to allow ventilation even during rainy weather.

- Turn the window crank clockwise to open; counterclockwise to close.

### **SIDE SLIDER WINDOW**

The passenger side of the vehicle has a sliding window for high-volume ventilation.

- Lift the latch handle upward and slide the window to the side.

### **FRONT CURTAIN**

The privacy curtain attaches to forward headliner area of the driver's compartment with press-on fabric fastening material.

- Hold curtain with top fastener strip facing outward toward side windows and windshield.
- Beginning at the rear corner of one side window, press the strip onto the fastener discs, working your way around the front to the other side window.

### **REAR CURTAIN**

The rear curtain is attached to the liftgate window with slide track fasteners.

- To open or close curtain, grasp both the top and bottom of one end of the curtain and pull evenly across window.
- To remove the curtain for dry cleaning, remove the stop screws at the ends of the slide tracks and slide the curtain off.

- Grasp both the top and bottom of one side of the curtain and pull evenly across the window.

### **PLEATED WINDOW SHADES**

Grasp bottom edge and pull evenly downward to close or upward to open.

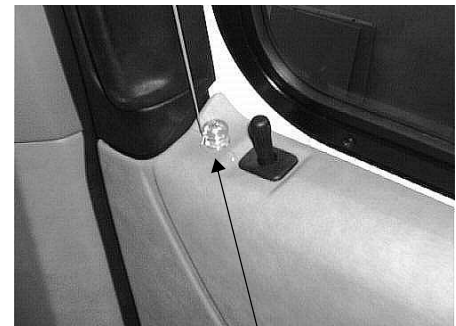

Tension Spool

### **Tension Adjustment:**

The tension of the pleated shades can be adjusted if they become loose and will not stay up when raised, or they are too tight and are difficult to raise and lower.

To tighten the tension, simply wrap the lower end of the guide cords (on each side of the shade) a few turns around the spools at the lower corners of the shades.

To loosen the tension, unwrap the guide cords from the spools one turn at a time until desired tension is achieved.

### **LUGGAGE TRAY**

The exterior roof cap above the driver compartment has a recessed area for extra luggage carrying capacity. This area also features tie-down bars for securing the cargo and tarps, if necessary.



### **RADIO/CASSETTE PLAYER**

Most models are available with a standard or optional AM/FM radio/cassette player that provides high quality stereo sound for your traveling and living enjoyment. Refer to your Owner Information binder for operating and care instructions.

### **REAR STORAGE COMPARTMENT**

Holds auxiliary (coach) battery, vehicle jack, waste water drain hose and external power cord (shoreline). It also contains the auxiliary battery main circuit breaker. (See page 3-4 for coach battery circuit breaker information.)

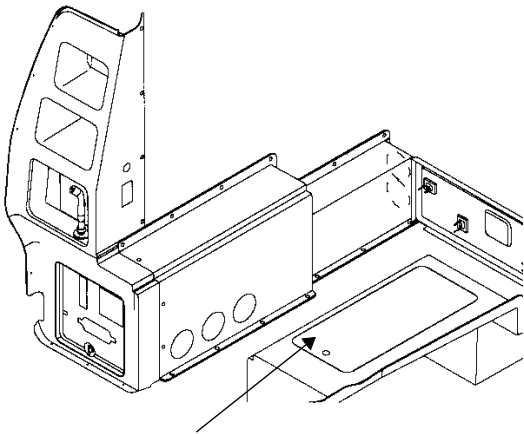

**Rear Storage Compartment**

### **CARE OF POP-UP CANVAS SIDES**

This canvas has been treated to repel water, resist mildew, and minimize shrinkage.

1. Vacuum or hose down occasionally. Brushing with a cloth or soft brush. Wash only with clear water. Detergents or solvents may remove the waterproofing. Dry before folding.
2. Canvas should be stored only when dry and clean.
3. When closing your camper, make sure that the canvas is folded in neatly and is not pinched or in contact with any sharp object.
4. Air your camper frequently.

#### **CAUTION**

Never store the canvas wet for extended periods because mold and mildew can form and destroy the material. If the roof must be lowered while the canvas is wet, raise the roof again as soon as possible to allow canvas to dry.

The use of insect sprays and other aerosol sprays near your canvas may impair the water repellency of the fabric and cause leakage.

### **UPHOLSTERY**

We recommend a weekly routine of vacuuming all fabrics throughout the vehicle to prevent an accumulation of dirt which can detract from the appearance and shorten the life of carpet and fabrics.

Some fabrics used in this vehicle may contain fire retardant and lightfastness additives which can be damaged by use of improper cleaning products. Some water-based household cleaning products are not formulated for use on fabrics and may cause excessive shrinkage or fading. Always test any cleaning product on a hidden area of fabric before using on visible areas. For best results, fabric cleaning should be referred to

a professional carpet and upholstery cleaner. We recommend dry cleaning curtains for best results

*NOTE: To minimize fading of upholstery and other interior fabrics caused by excessive sunlight, the blinds or shades should be closed when the vehicle is parked for an extended period of time.*

### **SPOTS AND STAINS**

Spots or stains should be treated as soon as possible before they “set in” to avoid permanent damage. Always start from the outside of a spot or stain and work inward to avoid spreading it. Use a clean cloth or sponge and turn frequently to an unused area of the cloth or sponge as you clean.

Some stains or soils, such as lipstick, ink, grease or mustard, are extremely difficult or impossible to remove completely and should receive immediate attention. Consult a professional carpet and upholstery cleaner for assistance.

### **VINYL FABRICS**

Vinyl should be cleaned with a soft, damp cloth and a mild detergent only. Do not use solvents. Solvents may damage the surface of the vinyl.

### **CABINETS**

Cabinets and doors may be cleaned with a mild, water-based cleaner and a soft cloth. Do not use solvents or abrasive cleaners.

### **TABLES AND GALLEY COVER**

Work surfaces are covered with a plastic laminate that resists solvents, stains and scratches. A coat of furniture wax applied to these surfaces on the counters and table will help preserve their beauty and make cleaning easier. Always clean the surface before applying wax.

### STAINLESS STEEL SINK AND COUNTER-TOP

The stainless steel sink can be cleaned with soap or detergent. Rinse thoroughly with warm water and wipe dry to avoid streaks.

Use a mild abrasive for stubborn stains. Work in the direction of the polish lines. To keep the original finish, polish with a wax cleaner and rub with a dry soft cloth.

#### WARNING

Salt, mustard and mayonnaise may cause pitting. If spilled, clean immediately.

### RANGE AND REFRIGERATOR

For care and appearance maintenance of the range and refrigerator, refer to the operation and maintenance manual for each of the individual appliances included in your Owner Information binder.

### PREPARING VEHICLE FOR STORAGE

Properly preparing your vehicle for storage will lessen the possibility of damage to your vehicle. Prepare the motor home for vacancy just as you would if you were leaving your house for an extended period.

- Remove all perishables from cabinets and refrigerator.
- Prop refrigerator door open.
- Turn off LP gas tank.
- Drain water tank and holding tank
- Close shades to protect upholstery from sunlight.

### Cold Weather Storage Procedure (Winterizing)

If you store your vehicle through the winter, or in cold climates, you need to take extra precautions to protect systems that can be damaged by freezing temperatures.

1. Completely drain the waste water holding tank at an approved waste disposal site. Close the dump valve after draining to prevent entry by rodents and insects. Refit the dust cap onto the drain outlet.

2. Level the vehicle and drain the fresh water tank and water lines as described in the following steps.
3. Open the water line drain valve by turning the valve handle clockwise until it stops. To close the valve, turn the handle counter-clockwise until it stops. The water will drain onto the ground from a tube through the floor of the vehicle, just ahead of the rear axle.

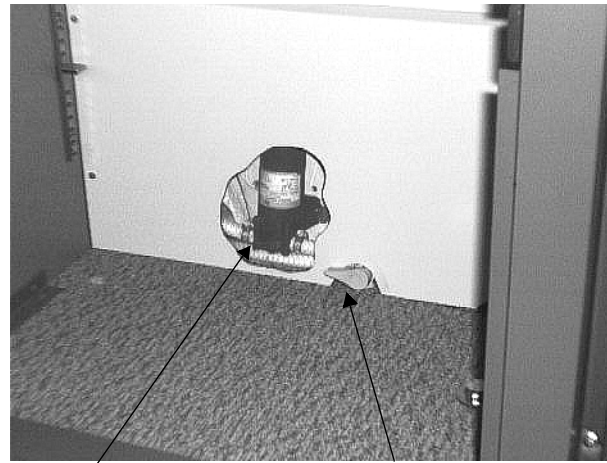

Water Pump

Water Line Drain Valve

4. Open the galley faucet to turn on the water pump. This will “power drain” the tank and lines. (Some water will be pumped into the sink and drain into the waste water holding tank, which must be redrained after this procedure is done.)
5. Pull the rear sprayer head out to straighten the hose, then open the sprayer head valve to allow drainage.
6. When water stops flowing from the galley faucet and rear spray head, close the faucet to turn off the water pump.
7. Close rear sprayer valve to avoid contamination by dirt or insects. Replace sprayer head and hose into the holder.
8. Close the water line drain valve by turning counter-clockwise fully.
9. Pour about 1 cup of non-toxic RV water system antifreeze into the sink drain. This prevents any holding tank odors from entering the vehicle during storage.

**WARNING**

NEVER use automotive antifreeze/coolant in your RV water system. Automotive antifreeze contains ethylene glycol which, if ingested, can cause blindness and can be fatal.

10. Place a bucket beneath the waste water dump valve outlet and re-drain the waste holding tank of any clean water that entered during "drain" procedure.

Close dump valves to prevent valve shafts from rusting and to prevent entry by rodents and insects. Refit the dust cap onto the drain outlet.

Your drainage and fresh water systems are now totally winterized.

11. Have the vehicle chassis completely serviced.
12. Wash and wax the exterior.
13. Inspect all seams and seal around doors, windows, vents, and any other joints. Replace or repair any that are damaged. Sealing materials and compounds can be purchased from your dealer. Badly damaged weather seals may need to be replaced by your dealer.
14. Close all windows and vents. Protect all appliance vent openings from contamination by animals or insects (e.g. bird nests, wasp nests, etc.)
15. Lubricate all door hinges and locks.
16. Clean the interior of the coach. Dirt and stains are more easily removed when fresh.
17. Remove all foods and items that may cause odors.
18. Clean and defrost the refrigerator. Leave the door slightly ajar to allow any odors to dissipate. Place an open box of baking soda inside the refrigerator to help absorb odors.
19. Turn the furnace thermostat switch on the bottom of the thermostat to OFF.
20. Disconnect all chassis and auxiliary battery cables. (See Battery Information in Section 3).

21. Fully charge all batteries. Batteries must have at least 80% charge to survive freezing temperatures and long periods of non-use. (See Battery Information in Section 3.)

**REMOVAL FROM STORAGE**

1. Completely air out the camper.
2. Have the entire LP gas system checked for leaks.
3. Check window operation.
4. Check cabinet and door hinges. Lubricate with penetrating oil, if necessary.
5. Add a few gallons of water to the fresh water tank and check for leaks especially at junctions. Sanitize the water system as outlined under "Disinfecting the Fresh Water System" in Section 4.
6. Check operation of all faucets to be sure faucet seals have not hardened during storage.
7. Add water to the holding tank using the sink faucet. Check to be sure dump valve seals tightly.
8. Check around all appliances for obstructions and ensure that all vent openings are clear.
9. Start refrigerator and check for proper cooling.
10. Clean counter surfaces and apply a thin coat of wax.
11. Replace batteries if necessary and check out electrical system to make sure all lights and electrical components operate.
12. Check tires for proper cold inflation pressure.
13. After washing accumulated winter grime from the vehicle, it is important to carefully inspect the seams and sealants for separation or cracks that may have appeared around the window frames, thru-floor passages and any other joints. Re-sealing is quite simple and the material is quickly and easily applied. Appropriate compounds are available from your dealer. Also, inspect weather seals around pop-up top, etc., and if necessary, have your dealer replace immediately.



(See also SAFETY PRECAUTIONS, Section 1 of this manual.)

### **MAXIMUM OCCUPANCY**

The following label is placed in a visible location in the driver compartment.

**BELTED SEATING POSITIONS MAY EXCEED SLEEPING CAPACITY OF THIS VEHICLE. SEE OWNERS MANUAL FOR OCCUPANCY AND WEIGHT RESTRICTIONS.**

The number of belted seating positions in your motor home may exceed the number people used to determine maximum coach occupancy, called the Net Carrying Capacity (NCC) in the U.S. or Cargo Carrying Capacity (CCC) in Canada.

To calculate the NCC or CCC, Winnebago uses vehicle sleeping capacity, however your coach may be equipped with more belted seating positions than sleeping positions to give passengers a choice of seating arrangements. You may use all of the belted seating positions providing you stay within your vehicle's GVWR listed on the Vehicle Certification Label. However you use or load your vehicle, it is your responsibility to keep the weight within its stated gross vehicle weight rating.

### **VEHICLE WEIGHT**

*NOTE: We recommend that you dump the holding tank before traveling to avoid carrying unnecessary weight.*

#### **CAUTION**

The weight of the loaded vehicle (including options, attachments, passengers, water, fuel, luggage and all other cargo) must not exceed the GVWR or GAWR of either axle.

### **TRAILER TOWING**

See your Volkswagen EuroVan owner's manual for specific information regarding towing weight limitations, hitch requirements and special precautions.

### **PRE-TRAVEL CHECKLIST**

- \_\_\_ Fire Extinguisher - Make sure it is fully charged and secured in mounting bracket.
- \_\_\_ Lights - Make sure all exterior lights operate.
- \_\_\_ WasteWater Drain Hose - Unhook and store.
- \_\_\_ Loose Items Inside the vehicle - Store or secure items in rear compartment.
- \_\_\_ Set the refrigerator in 12-Volt DC mode for traveling. (Remember to reselect 110-volt or LP gas mode after arriving at destination.)
- \_\_\_ Fuel Tank - Check level.
- \_\_\_ Exterior Door - Make sure doors are closed and locked.
- \_\_\_ Seats - Adjusted for comfortable position and locked in place.
- \_\_\_ Mirrors - Adjust for maximum visibility from driver's seat.

#### **WARNING**

Before driving your vehicle, be sure you have read the entire operator's manual and that you understand your vehicle's equipment completely and how to use the equipment safely.

### **SEVERE WEATHER INFORMATION**

One of the more serious conditions affecting the traveler and camper is that of the weather. Whether you desire the high mountain terrain, the lower deserts and flatlands or the plains of the midwest, the weather is always with you and subject to change, sometime with little or no warning. However, adequate warnings are normally broadcast over local radio and TV stations.

Campers often seek secluded areas for weekend recreation or extended summer vacations. Many recreational areas are vulnerable to severe weather situations, especially flash flooding conditions. A few simple precautions may help

lessen the hazards of flash flooding or reduce your immediate involvement.

*NOTE: We recommend that all occupants become familiar with these safety precautions and be constantly alert to changes in weather.*

- Be alert, keep an eye to the sky because thunderstorms can form at any time in any month of the year. Thunderstorms can produce heavy amounts of rain over a small area in a short time which may result in a flash flood. Listen frequently to weather reports on radio for weather and flood conditions.
- When camping near a stream, leave plenty of sloping bank between you and the stream.
- Avoid deep canyons and dry washes during stormy or threatening weather. Be aware of alternate exits.
- If heavy rain occurs, move to high ground immediately (at least 30-40 feet above the canyon floor or bottom of dry wash).
- During a flash flood, if you can't move your vehicle, abandon it. Don't attempt to return to your vehicle before the water has receded.
- Don't attempt to wade to your vehicle if the water is above your knees - fast moving water exerts an enormous amount of pressure, making it extremely difficult to remain standing or walking.
- Don't try to drive through flooded areas.
- Follow instructions of local authorities. Leave immediately when advised to do so. Many lives have been lost because people didn't heed warnings.
- Stock enough survival supplies to last for several days, including food, water, first aid equipment and necessary medications. In desert areas during hot weather allow 3-4 gallons of drinking water per person, per day.

- Before you leave home, inform someone of your destination and when you expect to return. Authorities at your destination should be notified immediately if you do not return on time.

#### **REMEMBER THESE TERMS:**

**WATCH:** Severe weather may develop in the specified area. Be alert and prepare for possibility of an emergency.

**WARNING:** Severe weather is occurring, or is imminent in certain areas. Move to a safe location immediately.

We highly recommend that the motor home operator obtain a weather radio. These radios offer up-to-date weather condition broadcasts. During good weather, the latest information and forecasts are tape-recorded by local National Weather Service offices in messages that last from three to five minutes. These messages are replayed continually 24 hours a day. The recorded messages are revised every three to four hours, or more frequently when appropriate.

When severe weather threatens, forecasters at the local National Weather Service office interrupt the broadcasts with storm warnings, either recorded or "live" as the situation demands.

The frequencies used for NOAA Weather Radio (National Oceanic and Atmospheric Administration) nationwide area 162.40, 162.475 or 162.55 megahertz.

#### **CAMPSITE SET-UP**

Try to pick as level a spot as possible on which to park your camper.

Leveling the vehicle is important, not only for your comfort, but for efficient operation of plumbing and appliances as well. (See "Leveling" on page 5-3 for more information.) Also, water and holding tank level indicators may give false readings because water level is greater at one side of the tank than the other.

The short wheelbase of your Camper should make finding a level camping site relatively easy. There may be camping areas, however, where a level site is not available. In this situa-



tion, you can use wooden boards or planks stacked to a height necessary to level your vehicle; a method called “blocking”.

The planks are set on the ground, longest length first, with gradually shorter lengths stacked in a step-like ramp formation to allow the tire to climb onto the top plank. See illustration.

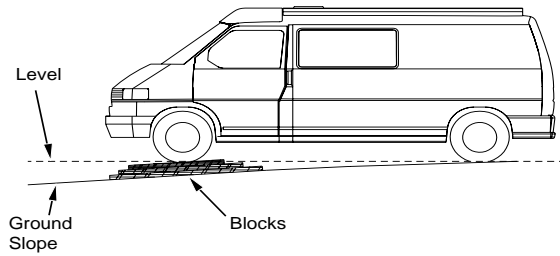

Vehicle Leveling with Blocks



---

<b>A</b>		
AC 110-Volt Electrical System .....	3-1	
Air in the LP Gas Tank .....	2-3	
Alarm, LP Gas .....	1-4	
Automotive Battery .....	3-3	
Auxiliary (Coach) Battery .....	3-3	
<b>B</b>		
Battery, Automotive .....	3-3	
Batteries, Auxiliary (Coach) .....	3-3	
Battery Circuit Breakers, Coach .....	3-4	
Battery Condition Meter .....	3-5, 5-5	
Battery Storage and Maintenance .....	3-5	
Bed, Upper .....	5-7	
Bed, Rear Seat .....	5-8	
<b>C</b>		
Cabinets .....	6-1	
Campsite Set-Up (Leveling) .....	7-2	
Canvas, Care of Pop-Up Roof .....	6-1	
Capacities, Tank .....	0-3, 5-1	
Carbon Monoxide Alarm .....	1-6	
Carbon Monoxide Warning .....	1-5	
Care of Pop-Up Roof Canvas .....	6-1	
Cassette Player, Radio .....	5-14	
Center Seat .....	5-10	
Charging Section, Power Converter .....	3-3	
Checklist, Pre-Travel .....	7-1	
Circuit Breakers, 110-Volt .....	3-2	
Circuit Breakers, 12-Volt .....	3-4	
Coach Battery Circuit Breakers .....	3-4	
Cold Weather Storage (Winterizing) .....	6-2	
Compartment, Rear Storage .....	5-14	
Curtains, Front & Rear .....	5-13	
<b>D</b>		
DC 12-Volt Electrical System .....	3-3	
Defects, Reporting Safety .....	0-2	
Disinfection of Fresh Water Tank .....	4-2	
Drain Valve, Water .....	4-2	
Drinking and Driving .....	0-2	
Dumping Holding Tank .....	4-3	
<b>E</b>		
Electrical System, 110-volt AC .....	3-1	
Electrical System, 12-volt DC .....	3-3	
Electrical Warnings .....	1-4	
Exit Latch, Rear Liftgate .....	1-6	
Exterior Features .....	0-3	
External Power Cord (Shoreline) .....	3-1	
<b>F</b>		
Faucet, Galley Sink .....	4-1	
Features, Exterior .....	0-3, 5-1	
Features, Interior .....	0-4, 5-1	
Fire Extinguisher .....	1-6	
Formaldehyde Warning .....	1-5	
Fresh Water Tank, Disinfection of .....	4-2	
Fresh Water Tank Filling .....	4-1	
Front & Rear Curtains .....	5-13	
Fuel & LP Gas .....	1-2	
Fuel Types, Selecting LP .....	2-1	
Furnace, LP Gas .....	5-5	
<b>G</b>		
Galley Cover, and Tables .....	6-1	
Galley Sink Faucet .....	4-1	
Gas Alarm, LP .....	1-4	
Gas Leaks, LP .....	1-4	
General Warnings .....	1-2	
Ground Fault Circuit Interrupter (GFCI) .....	3-2	
<b>H</b>		
Holding Tank, Waste Water .....	4-3	
Holding Tank, Dumping .....	4-3	
Holding Tank Level Indicators .....	4-3	
How Long Will a Tank Last .....	2-5	
How LP Gas Works .....	2-1	
Humidity & Condensation .....	5-5	
<b>I</b>		
Interior Features .....	0-4, 5-2	
Interior Lights .....	5-12	
<b>L</b>		
Latch, Rear Liftgate Exit .....	1-6	
Leveling, Campsite Set-Up .....	7-2	
Lights, Interior .....	5-12	
Loading Warnings .....	1-5	
LP Gas Alarm .....	1-4	
LP Gas Furnace .....	5-5	
LP Gas Leaks .....	1-3	
LP Gas Level .....	5-5	
LP Gas Pressure Regulator .....	2-4	
LP Gas Supply .....	2-1	
LP Gas System, Safe Use Of .....	2-1	
LP Gas Tank System .....	2-2	

---

**INDEX**

LP Tank, Refilling .....	2-2	Sink Faucet, Galley .....	4-1
Luggage Tray (Roof) .....	5-13	Sleeping Facilities .....	5-7
<b>M</b>		Spots and Stains .....	6-1
Monitor Panel .....	5-4	Sprayer Head, Rear .....	4-1
<b>O</b>		Stainless Steel Sink and Countertop .....	6-2
Operators Manuals .....	0-1	Storage, Cold Weather (Winterizing) .....	6-2
Options and Equipment .....	0-1	Storage, Removal from .....	6-3
Outlets, 110-Volt .....	3-1	Storage Compartment, Rear .....	5-14
Outlets, 12-Volt .....	3-4	Switch, Water Pump .....	4-1
Owner Information Binder .....	0-1	<b>T</b>	
<b>P</b>		Tables .....	5-12
Pleated Side Window Shades .....	5-13	Tables and Galley Cover .....	6-1
Pop-Up Roof .....	5-6	Tank Capacities .....	0-3, 5-1
Pop-Up Roof Canvas, Care of .....	6-1	Tank Level Indicators .....	4-3
Power Control Center .....	3-2	Tank System, LP Gas .....	2-2
Power Converter Charging Section .....	3-3	Thermal Breaker .....	3-3
Power Cord, External (Shoreline) .....	3-1	Towing, Trailer .....	7-1
Pre-Travel Checklist .....	7-1	Trailer Towing .....	7-1
Pressure Regulator, LP Gas .....	2-4	Travel with LP Gas .....	2-3
Pump Switch, Water .....	4-1	<b>U</b>	
<b>R</b>		Upholstery .....	6-1
Radio/Cassette Player .....	5-14	Upper Bed .....	5-7
Range Top .....	5-3	<b>V</b>	
Rear Liftgate Exit Latch .....	1-7	Vehicle Weight .....	7-1
Rear Seat-Bed .....	5-8	Vinyl Fabrics .....	6-1
Rear Sprayer Head .....	4-1	<b>W</b>	
Rear Storage Compartment .....	5-14	Warning, Formaldehyde .....	1-5
Refilling LP Tank .....	2-2	Warning, Carbon Monoxide .....	1-5
Refrigerator .....	5-2	Warnings, General .....	1-2
Regulator, LP Gas Pressure .....	2-4	Warnings, Electrical .....	1-5
Removal from Storage .....	6-3	Warnings, Loading .....	1-5
Reporting Safety Defects .....	0-2	Warranty .....	0-1
Roof, Pop-Up .....	5-6	Waste Water Holding Tank .....	4-3
<b>S</b>		Water and Holding Tank Levels .....	5-5
Safe Use of LP Gas System .....	2-1	Water Drain Valve .....	4-2
Safety Defects, Reporting .....	0-2	Water Tank Filling .....	4-1
Seats, Center .....	5-10	Weather Information, Severe .....	7-1
Seat Belts .....	1-1	Window, Side Tip-Out .....	5-13
Seat-Bed, Rear .....	5-8	Window, Side Slider .....	5-13
Selecting LP Fuel Types .....	2-1	Window Shades, Pleated Side .....	5-13
Service Assistance .....	0-1	Winter use of LP Gas .....	2-5
Set-Up, Campsite (Leveling) .....	7-2	Winterizing, Cold Weather Storage .....	6-2
Severe Weather Information .....	7-1		
Shades, Pleated Side Window .....	5-13		
Shoreline - External Power Cord .....	3-1		
Side Tip-Out Window .....	5-12		
Side Slider Window .....	5-12		
Sink and Countertop, Stainless Steel .....	6-2		

**IMPORTANT  
SERIAL NUMBERS**

Motor Home (Coach): Year \_\_\_\_\_ Model \_\_\_\_\_ Serial \_\_\_\_\_

Chassis: Make \_\_\_\_\_ Serial (VIN) \_\_\_\_\_

Furnace: Brand \_\_\_\_\_ Model \_\_\_\_\_ Serial \_\_\_\_\_

Power Converter: Brand \_\_\_\_\_ Model \_\_\_\_\_ Serial \_\_\_\_\_

Range Brand \_\_\_\_\_ Model \_\_\_\_\_ Serial \_\_\_\_\_

Refrigerator Brand \_\_\_\_\_ Model \_\_\_\_\_ Serial \_\_\_\_\_

**EMERGENCY INFORMATION**

**Dealer**

Name \_\_\_\_\_

Address \_\_\_\_\_

Phone \_\_\_\_\_

**INSURANCE POLICY**

Company \_\_\_\_\_

Policy Number \_\_\_\_\_

Phone \_\_\_\_\_





