

**SUZUKI**

---

***DR650SE***

---

**SERVICE MANUAL**

## FOREWORD

This manual contains an introductory description on SUZUKI DR650SE and procedures for its inspection/service and overhaul of its main components.

Other information considered as generally known is not included.

Read GENERAL INFORMATION section to familiarize yourself with outline of the vehicle and MAINTENANCE and other sections to use as a guide for proper inspection and service.

This manual will help you know the vehicle better so that you can assure your customers of your optimum and quick service.

\* This manual has been prepared on the basis of the latest specification at the time of publication.

If modification has been made since then, difference may exist between the content of this manual and the actual vehicle.

\* Illustrations in this manual are used to show the basic principles of operation and work procedures.

They may not represent the actual vehicle exactly in detail.

\* This manual is intended for those who have enough knowledge and skills for servicing SUZUKI vehicles. Without such knowledge and skills, you should not attempt servicing by relying on this manual only.

Instead, please contact your nearby authorized SUZUKI motorcycle dealer.

## IMPORTANT

All street-legal Suzuki motorcycles with engine displacement of 50cc or greater are subject to Environmental Protection agency emission regulations. These regulations set specific standards for exhaust emission output levels as well as particular servicing requirements. This manual includes specific information required to properly inspect and service DR650SE in accordance with all EPA regulations. It is strongly recommended that the chapter on Emission Control, Periodic Servicing and Carburetion be thoroughly reviewed before any type of service work is performed.

Further information concerning the EPA emission regulations and U.S. Suzuki's emission control program can be found in the U.S. SUZUKI EMISSION CONTROL PROGRAM MANUAL/SERVICE BULLETIN.

## GROUP INDEX

GENERAL INFORMATION

1

PERIODIC MAINTENANCE

2

ENGINE

3

FUEL AND LUBRICATION SYSTEM

4

CHASSIS

5

ELECTRICAL SYSTEM

6

SERVICING INFORMATION

7

EMISSION CONTROL INFORMATION

8

DR650SEV/W/X/Y ('97/'98/'99/'00-MODEL)

9

DR650SEK1 ('01-MODEL)

10

**SUZUKI MOTOR CORPORATION**

Motorcycle Service Department

## HOW TO USE THIS MANUAL

### TO LOCATE WHAT YOU ARE LOOKING FOR:

1. The text of this manual is divided into sections.
2. As the title of these sections are listed on the previous page as GROUP INDEX, select the section where what you are looking for belong.
3. Holding the manual as shown at the right will allow you to find the first page of the section easily.
4. On the first page of each section, its contents are listed. Find the item and page you need.

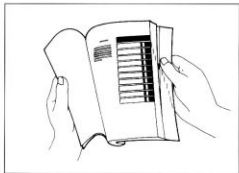

## COMPONENT PARTS AND WORK TO BE DONE





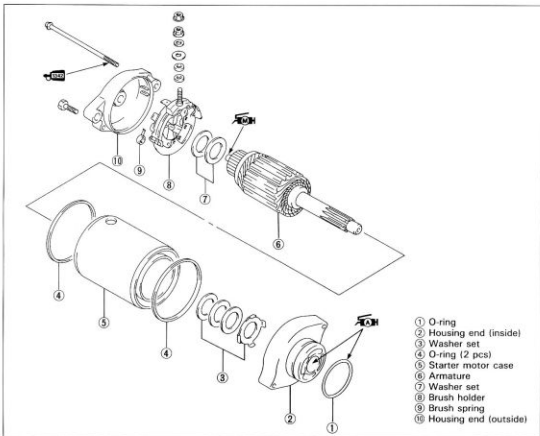









Under the name of each system or unit, its exploded view is provided with work instruction and other service information such as the tightening torque, lubricating points and locking agent points.

Example: Front wheel



## SYMBOL

Listed in the table below are the symbols indicating instructions and other information necessary for servicing and meaning associated with them respectively.

SYMBOL	DEFINITION	SYMBOL	DEFINITION
	Torque control required. Data beside it indicates specified torque.		Apply THREAD LOCK SUPER "1303". (99000-32030)
	Apply oil. Use engine oil unless otherwise specified.		Use fork oil. (99000-99044-10G)
	Apply SUZUKI SUPER GREASE "A". (99000-25030)		Apply or use brake fluid.
	Apply SUZUKI SILICONE GREASE. (99000-25100)		Measure in voltage range.
	Apply SUZUKI MOLY PASTE. (99000-25140)		Measure in resistance range.
	Apply SUZUKI BOND "1207B". (99104-31140)		Measure in current range.
	Apply THREAD LOCK "1342". (99000-32050)		Use special tool.
	Apply THREAD LOCK SUPER "1360". (99000-32130)		



## CONTENTS

<b>WARNING/CAUTION/NOTE</b> .....	<b>1- 1</b>
<b>GENERAL PRECAUTIONS</b> .....	<b>1- 1</b>
<b>SUZUKI DR650SET ('96-MODEL)</b> .....	<b>1- 3</b>
<b>SERIAL NUMBER LOCATION</b> .....	<b>1- 3</b>
<b>FUEL AND OIL RECOMMENDATION</b> .....	<b>1- 3</b>
<b>FUEL</b> .....	<b>1- 3</b>
<b>ENGINE OIL</b> .....	<b>1- 4</b>
<b>BRAKE FLUID</b> .....	<b>1- 4</b>
<b>FRONT FORK OIL</b> .....	<b>1- 4</b>
<b>BREAK-IN PROCEDURES</b> .....	<b>1- 4</b>
<b>INFORMATION LABELS</b> .....	<b>1- 5</b>
<b>SPECIFICATIONS</b> .....	<b>1- 7</b>
<b>COUNTRY OR AREA</b> .....	<b>1- 9</b>

## WARNING/CAUTION/NOTE

Please read this manual and follow its instructions carefully. To emphasize special information, the symbol and the words WARNING, CAUTION and NOTE have special meanings. Pay special attention to the messages highlighted by these signal words.

### **⚠ WARNING**

Indicates a potential hazard that could result in death or injury.

### **⚠ CAUTION**

Indicates a potential hazard that could result in vehicle damage.

### *NOTE:*

*Indicates special information to make maintenance easier or instructions clearer.*

Please note, however, that the warnings and cautions contained in this manual cannot possibly cover all potential hazards relating to the servicing, or lack of servicing, of the motorcycle. In addition to the WARNINGS and CAUTIONS stated, you must use good judgement and basic mechanical safety principles. If you are unsure about how to perform a particular service operation, ask a more experienced mechanic for advice.

## GENERAL PRECAUTIONS

### **⚠ WARNING**

- Proper service and repair procedures are important for the safety of the service mechanic and the safety and reliability of the vehicle.
- When 2 or more persons work together, pay attention to the safety of each other.
- When it is necessary to run the engine indoors, make sure that exhaust gas is forced outdoors.
- When working with toxic or flammable materials, make sure that the area you work in is well-ventilated and that you follow all of the material manufacturer's instructions.
- Never use gasoline as a cleaning solvent.
- To avoid getting burned, do not touch the engine, engine oil or exhaust system during or for a while after engine operation.
- After servicing fuel, oil, exhaust or brake systems, check all lines and fittings related to the system for leaks.

**⚠ CAUTION**

- If parts replacement is necessary, replace the parts with Suzuki Genuine Parts or their equivalent.
- When removing parts that are to be reused, keep them arranged in an orderly manner so that they may be reinstalled in the proper order and orientation.
- Be sure to use special tools when instructed.
- Make sure that all parts used in reassembly are clean, and also lubricated when specified.
- When use of a certain type of lubricant, bond, or sealant is specified, be sure to use the specified type.
- When removing the battery, disconnect the negative cable first and then the positive cable. When reconnecting the battery, connect the positive cable first and then the negative cable, and replace the terminal cover on the positive terminal.
- When performing service to electrical parts, if the service procedures not require use of battery power, disconnect the negative cable the battery.
- Tighten cylinder head and case bolts and nuts, beginning with larger diameter and ending with smaller diameter, from inside to outside diagonally, to the specified tightening torque.
- Whenever you remove oil seals, gaskets, packing, O-rings, locking washers, cotter pins, circlips, and certain other parts as specified, be sure to replace them with new ones. Also, before installing these new parts, be sure to remove any left over material from the mating surfaces.
- Never reuse a circlip. When installing a new circlip, take care not to expand the end gap larger than required to slip the circlip over the shaft. After installing a circlip, always ensure that it is completely seated in its groove and securely fitted.
- Do not use self-locking nuts a few times over.
- Use a torque wrench to tighten fastners to the torque values when specified. Wipe off grease or oil if a thread is smeared with them.
- After reassembly, check parts for tightness and operation.

- To protect environment, do not unlawfully dispose of used motor oil and other fluids: batteries, and tires.
- To protect Earth's natural resources, properly dispose of used vehicles and parts.

## SUZUKI DR650SET ('96-MODEL)



RIGHT SIDE



LEFT SIDE

\*Difference between photographs and actual motorcycles depends on the markets.

## SERIAL NUMBER LOCATION

The frame serial number or V.I.N. (Vehicle Identification Number) ① is stamped on the right side of the steering head pipe. The engine serial number ② is located on the left side of the crankcase. These numbers are required especially for registering the machine and ordering spare parts.

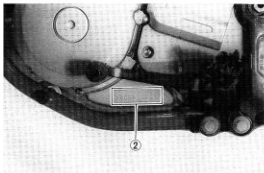
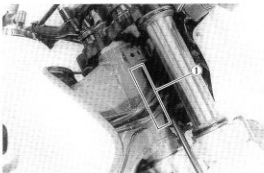

## FUEL AND OIL RECOMMENDATION

## FUEL (For U.S.A. model)

1. Use only unleaded gasoline of at least 87 pump octane ( $\frac{R+M}{2}$ ) method or 91 octane or higher rated by the research method.
2. Suzuki recommends that customers use alcohol free, unleaded gasoline whenever possible.
3. Use of blended gasoline containing MTBE (Methyl Tertiary Butyl Ether) is permitted.
4. Use of blended gasoline/alcohol fuel is permitted, provided that the fuel contains not more than 10% ethanol. Gasoline/alcohol fuel may contain up to 5% methanol if appropriate cosolvents and corrosion inhibitors are present in it.
5. If the performance of the vehicle is unsatisfactory while using blended gasoline/alcohol fuel, you should switch to alcohol-free unleaded gasoline.
6. Failure to follow these guideline could possibly void applicable warranty coverage. Check with your fuel supplier to make sure that the fuel you intend to use meets the requirements listed above.

## FUEL (For Canadian model)

Use only unleaded gasoline of at least 87 pump octane ( $\frac{R+M}{2}$ ) method or 91 octane or higher rated by the research method.

## FUEL (For the other models)

Gasoline used should be graded 85–95 octane (Research Method) or higher. An unleaded gasoline type is recommended.

**ENGINE OIL (For U.S.A. model)**

SUZUKI recommends the use of SUZUKI PERFORMANCE 4 MOTOR OIL or an oil which is rated SE, SF or SG under the API (American Petroleum Institute) classification system. The viscosity rating is SAE 10W/40. If an SAE 10W/40 motor oil is not available, select an alternate according to the right chart.

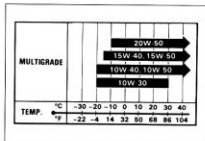
**ENGINE OIL (For the other models)**

Make sure that the engine oil you use comes under API classification of SE, SF or SG and that its viscosity rating is SAE 10W/40. If an SAE 10W/40 motor oil is not available, select an alternate according to the right chart.

**BRAKE FLUID**

Specification and classification: DOT 4

**▲ WARNING**

Since the brake system of this motorcycle is filled with a glycol-based brake fluid by the manufacturer, do not use or mix different types of fluid such as silicone-based and petroleum-based fluid for refilling the system, otherwise serious damage will result. Do not use any brake fluid taken from old or used or unsealed containers. Never re-use brake fluid left over from a previous servicing, which has been stored for a long period.

**FRONT FORK OIL**

Use fork oil # 10

**BREAK-IN PROCEDURES**

During manufacture only the best possible materials are used and all machined parts are finished to a very high standard but it is still necessary to allow the moving parts to "BREAK-IN" before subjecting the engine to maximum stresses. The future performance and reliability of the engine depends on the care and restraint exercised during its early life. The general rules are as follows.

- Keep to these break-in procedures:

**Initial 800 km ( 500 miles): Less than 1/2 throttle**

**Up to 1 600 km (1 000 miles): Less than 3/4 throttle**

- Upon reaching an odometer reading of 1 600 km (1 000 miles) you can subject the motorcycle to full throttle operation.
- Do not maintain constant engine speed for an extended time period during any portion of the break-in. Try to vary the throttle position.

## INFORMATION LABELS

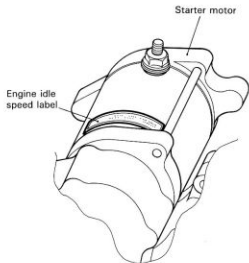
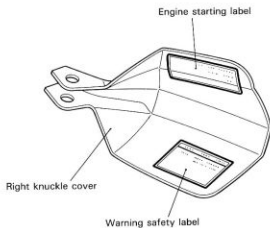
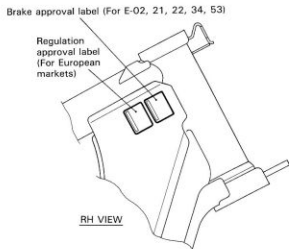
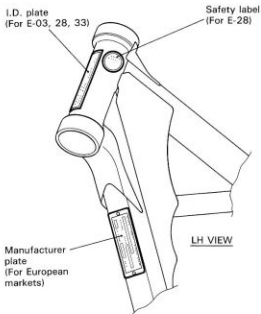

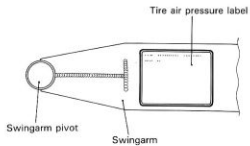
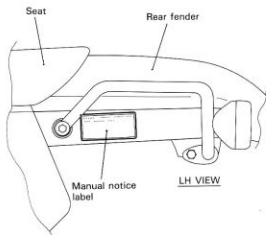
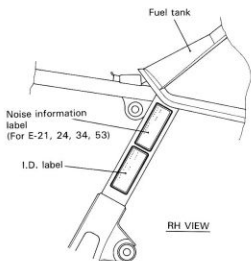
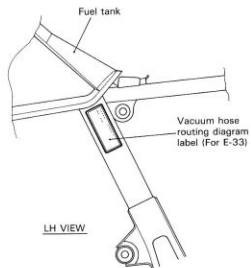

## SPECIFICATIONS

### DIMENSIONS AND DRY MASS

Overall length.....	2 345 mm (92.3 in) .....	E18, 22
	2 325 mm (91.5 in) .....	E18, 22 (Low seat)
	2 255 mm (88.8 in) .....	Others
	2 235 mm (88.0 in) .....	Others (Low seat)
Overall width .....	865 mm (34.1 in)	
Overall height.....	1 205 mm (47.4 in)	
	1 165 mm (45.9 in) .....	(Low seat)
Wheelbase.....	1 490 mm (58.7 in)	
	1 475 mm (58.1 in) .....	(Low seat)
Ground clearance.....	265 mm (10.4 in)	
	225 mm ( 8.9 in) .....	(Low seat)
Seat height .....	885 mm (34.8 in)	
	845 mm (33 in) .....	(Low seat)
Dry mass.....	147 kg (324 lbs)	

### ENGINE

Type.....	Four-stroke, air-cooled, with SACS, OHC
Valve clearance (IN).....	0.08—0.13 mm (0.003—0.005 in)
(EX).....	0.17—0.22 mm (0.007—0.009 in)
Number of cylinders.....	1
Bore.....	100 mm (3.937 in)
Stroke.....	82 mm (3.228 in)
Piston displacement.....	644 cm <sup>3</sup> (39.3 cu. in)
Compression ratio.....	9.5 : 1
Carburetor.....	BST40, single
Air cleaner.....	Polyurethane foam element
Starter system.....	Electric
Lubrication system.....	Wet sump

### TRANSMISSION

Clutch.....	Wet multi-plate type	
Transmission.....	5-speed constant mesh	
Gearshift pattern.....	1-down, 4-up	
Primary reduction ratio.....	2.178 (61/28)	
Gear ratios, Low.....	2.416 (29/12)	
2nd.....	1.625 (26/16)	
3rd.....	1.238 (26/21)	
4th.....	1.000 (21/21)	
Top.....	0.826 (19/23)	
Final reduction ratio.....	2.800 (42/15) .....	E03,28,33
	2.733 (41/15) .....	Others
Drive chain.....	DID525 V9, 110 links	



**CHASSIS**

Front suspension .....	Telescopic, coil spring, oil damped
Rear suspension .....	Link type, coil spring, gas/oil damped, spring pre-load fully adjustable, compression damping force adjustable
Front fork stroke .....	260 mm (10.2 in) 220 mm ( 8.7 in) ..... (Low seat)
Rear wheel travel .....	260 mm (10.2 in) 220 mm ( 8.7 in) ..... (Low seat)
Steering angle .....	43°
Caster .....	28° 30'
Trail .....	111 mm (4.37 in)
Turning radius .....	2.5 m (8.2 ft)
Front brake .....	Disc brake
Rear brake .....	Disc brake
Front tire size .....	90/90-21 54S, tube type
Rear tire size .....	120/90-17 64S, tube type

**ELECTRICAL**

Ignition type .....	Electronic ignition (CDI)
Ignition timing .....	10° B.T.D.C. at 1 500 rpm
Spark plug .....	NGK CR10E or NIPPONDENSO U31ESR-N
Battery .....	12V 28.8 kC (8 Ah)/10 HR
Generator .....	Three-phase A.C. generator
Fuse .....	30/10/10A
Headlight .....	12V 60/55W
Parking or city light .....	12V 4W ..... except E03, 24, 28, 33
Turn signal light .....	12V 21W
Tail/brake light .....	12V 5/21W
License plate light .....	12V 5W
Speedometer light .....	12V 3W
Neutral indicator light .....	12V 2W
High beam indicator light .....	12V 2W
Turn signal indicator light .....	12V 2W

**CAPACITIES**

Fuel tank, including reserve .....	12.0 L (3.2/2.6 US/Imp gal) ..... E33
	13.0 L (3.4/2.9 US/Imp gal) ..... Others
reserve .....	3.0 L (0.8/0.7 US/Imp gal)
Engine oil, oil change .....	2 300 ml (2.4/2.0 US/Imp qt)
with filter change .....	2 400 ml (2.5/2.1 US/Imp qt)
overhaul .....	2 600 ml (2.7/2.3 US/Imp qt)
Front fork oil (each leg) .....	565 ml (19.1/19.9 US/Imp oz)
	563 ml (19.0/19.8 US/Imp oz) ..... (Low seat)

**COUNTRY OR AREA**

The series of symbols on the left stand for the countries or area on the right.

SYMBOL	COUNTRY or AREA
E-02	U.K.
E-03	U.S.A.
E-04	France
E-15	Finland
E-16	Norway
E-17	Sweden
E-18	Switzerland
E-21	Belgium
E-22	Germany
E-24	Australia
E-25	Netherlands
E-28	Canada
E-33	California (U.S.A.)
E-34	Italy
E-37	Brazil
E-39	Austria
E-53	Spain

(E-15 and 16 countries are included in E-17.)  
(E-21 and 53 countries are included in E-34.)  
E-39 country is included in E-18.)

# PERIODIC MAINTENANCE

## CONTENTS

<b>PERIODIC MAINTENANCE SCHEDULE</b> .....	2- 1
<b>PERIODIC MAINTENANCE CHART</b> .....	2- 1
<b>LUBRICATION POINTS</b> .....	2- 2
<b>MAINTENANCE AND TUNE-UP PROCEDURES</b> .....	2- 3
<b>VALVE CLEARANCE</b> .....	2- 3
<b>SPARK PLUGS</b> .....	2- 4
<b>AIR CLEANER ELEMENT</b> .....	2- 5
<b>CARBURETOR</b> .....	2- 6
<b>FUEL LINE</b> .....	2- 7
<b>FUEL VALVE STRAINER</b> .....	2- 7
<b>CLUTCH</b> .....	2- 7
<b>ENGINE OIL AND OIL FILTER</b> .....	2- 8
<b>DRIVE CHAIN</b> .....	2- 9
<b>BRAKES</b> .....	2-10
<b>TIRES</b> .....	2-12
<b>SPARK ARRESTER</b> .....	2-13
<b>STEERING</b> .....	2-13
<b>FRONT FORKS</b> .....	2-14
<b>REAR SUSPENSION</b> .....	2-14
<b>EXHAUST PIPE AND MUFFLER BOLTS</b> .....	2-14
<b>CHASSIS BOLTS AND NUTS</b> .....	2-15
<b>COMPRESSION PRESSURE CHECK</b> .....	2-17
<b>OIL PRESSURE CHECK</b> .....	2-18

## PERIODIC MAINTENANCE SCHEDULE

**IMPORTANT:** The periodic maintenance intervals and service requirements have been established in accordance with EPA regulations. Following these instructions will ensure that the motorcycle will not exceed emission standards and it will also ensure the reliability and performance of the motorcycle.

The chart below lists the recommended intervals for all the required periodic service work necessary to keep the motorcycle operating at peak performance and economy. Mileages are expressed in terms of kilometer, miles and time for your convenience.

**NOTE:**

*More frequent servicing may be performed on motorcycles that are used under severe conditions.*

### PERIODIC MAINTENANCE CHART

INTERVAL: THIS INTERVAL SHOULD BE JUDGED BY ODOMETER READING OR MONTHS WHICHEVER COMES FIRST	km	1 000	6 000	12 000	18 000	24 000
	miles	600	4 000	7 500	11 000	15 000
	months	2	12	24	36	48
Valve clearance		I	—	I	—	I
Spark plugs		—	I	R	I	R
Air cleaner element		Clean every 3 000 km (2 000 miles).				
Carburetor idle rpm		I	I	I	I	I
Fuel line (EVAP hose ... California model only)		I	I	I	I	I
		Replace every 4 years.				
Fuel valve strainer		—	—	C	—	C
Clutch		I	I	I	I	I
Engine oil		R	R	R	R	R
Engine oil filter		R	—	R	—	R
Drive chain		I	I	I	I	I
		Clean and lubricate every 1 000 km (600 miles).				
Brakes		I	I	I	I	I
		—	I	I	I	I
Brake hose		Replace every 4 years.				
		—	I	I	I	I
Brake fluid		Change every 2 years.				
		—	I	I	I	I
Tires		—	I	I	I	I
Spark arrester		Clean every 6 000 km (4 000 miles). (For Canada and U.S.A.)				
Steering		I	—	I	—	I
Front forks		—	—	I	—	I
Rear suspension		—	—	I	—	I
Exhaust pipe and muffler bolts		T	—	T	—	T
Chassis bolts and nuts		T	T	T	T	T

NOTE: I: Inspection and adjust, clean, lubricate or replace as necessary.

R: Replace T: Tighten C: Clean

## LUBRICATION POINTS

Proper lubrication is important for smooth operation and long life of each working part of the motorcycle.

Major lubrication points are indicated below.

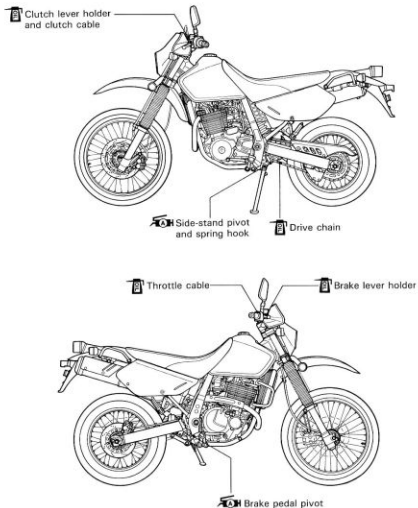

### NOTE:

- \* Lubricate exposed parts which are subject to rust, with a rust preventative spray whenever the motorcycle has been operated under wet or rainy conditions. If the spray is unavailable, use either motor oil or grease.
- \* Before lubricating each part, clean off any rusty spots and wipe off any grease, oil, dirt or grime.

## MAINTENANCE AND TUNE-UP PROCEDURES

This section describes the servicing procedures for each item of the Periodic Maintenance requirements.

### VALVE CLEARANCE

Inspect Initially at 1 000 km (600 miles, 2 months) and Every 12 000 km (7 500 miles, 24 months) thereafter.

The valve clearance specification is different for intake and exhaust valves.

Valve clearance adjustment must be checked and adjusted, 1) at the time of periodic inspection, 2) when the valve mechanism is serviced, and 3) when the camshaft is disturbed by removing it for servicing.

**Valve clearance (when cold):**

**IN.:** 0.08–0.13 mm (0.003–0.005 in)

**EX.:** 0.17–0.22 mm (0.007–0.009 in)

**NOTE:**

*Valve clearance is to be checked when the engine is cold. Both intake and exhaust valves must be checked and adjusted when the piston is at Top—Dead—Center (TDC) on the compression stroke.*

- Remove the frame covers, seat and fuel tank.
- Remove the spark plug and valve inspection caps, intake and exhaust.
- Remove the valve timing inspection plug and magneto cover cap.
- Turn the crankshaft counterclockwise with the box wrench to set the piston at T.D.C. on the compression stroke. (Turn the crankshaft until the “T” line ① on the magneto rotor is aligned with the center of hole on the magneto cover.)
- Insert the thickness gauge into the clearance between the valve stem end and the adjusting screw on the rocker arm.

 **09900-20803: Thickness gauge**  
**09917-14910: Valve clearance adjusting driver**

- If clearance is out of the specification, bring it into the specified range.
- Securely tighten the lock nut after adjustment is completed.

**CAUTION**

**Both right and left valve clearances, should be as closely set as possible.**

- Reinstall the spark plug, valve inspection caps, valve timing inspection plug and magneto cover cap.

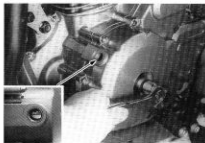

## SPARK PLUGS

Inspect Every 6 000 km (4 000 miles, 12 months) and  
Replace Every 12 000 km (7 500 miles, 24 months).

- Remove the spark plugs.

 09930-10121: Spark plug socket wrench set

	Standard	Hot type
NGK	CR10E	CR9E
ND	U31ESR-N	U27ESR-N



### CARBON DEPOSIT

Check to see the carbon deposit on the plug.  
If the carbon is deposited, remove it with a spark plug cleaner machine or carefully using a tool with a pointed end.

### SPARK PLUG GAP

Measure the plug gap with a thickness gauge if it is correct.  
If not, adjust it to the following gap.

Spark plug gap	Standard
	0.7–0.8 mm (0.028–0.031 in)

 09900-20803: Thickness gauge

### ELECTRODE'S CONDITION

Check to see the worn or burnt condition of the electrodes.  
If it is extremely worn or burnt, replace the plug. And also replace the plug if it has a broken insulator, damaged thread, etc.

### CAUTION

Confirm the thread size and reach when replacing the plug. If the reach is too short, carbon will be deposited on the screw portion of the plug hole and engine damage may result.

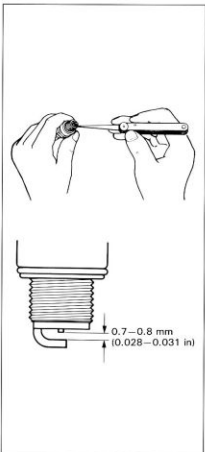

## AIR CLEANER ELEMENT

Clean Every 3 000 km (2 000 miles).

If the air cleaner is clogged with dust, intake resistance will be increased with a resultant decrease in power output and an increase in fuel consumption.

Check and clean the element in the following manner.

- Remove the left frame cover.
- Remove the air cleaner case cover by removing screws ①.
- Remove the air cleaner element by removing its support screw ②.
- Remove the polyurethane foam element ③ from the element frame ④.
- Fill a washing pan of a proper size with non-flammable cleaning solvent. Immerse the element in the cleaning solvent and wash it clean.
- Squeeze the cleaning solvent out of the washed element by pressing it between the palms of both hands.
- Immerse the element in motor oil, and squeeze the oil out of the element leaving it slightly wet with oil.

### NOTE:

Do not twist or wring the element because it will tear or the individual cells of the element will be damaged.

### CAUTION

Inspect the element carefully for rips, torn seams, etc. If any damage is noted, replace the element.

- Reinstall the cleaned or new cleaner element in the reverse order of removal.
- When installing the air cleaner element in the cleaner case, make sure that the "UP" mark comes upward.

### CAUTION

If driving under dusty conditions, clean the air cleaner element more frequently. The surest way to accelerate engine wear is to use the engine without the element or to use a ruptured element. Make sure that the air cleaner is in good condition at all times. Life of the engine depends largely on this component!

### NOTE:

When you clean the air cleaner element, drain water from the air cleaner drain hose by removing the drain plug.

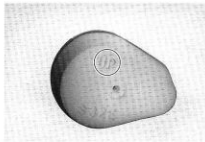
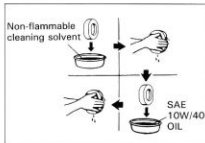
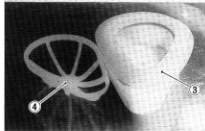
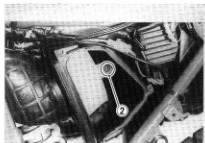
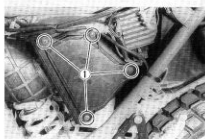



## CARBURETOR

Inspect Initially at 1 000 km (600 miles, 2 months) and Every 6 000 km (4 000 miles, 12 months) thereafter.

### THROTTLE CABLE ADJUSTMENT

A twin throttle cable system is used in this motorcycle. Cable ① is for pulling and cable ② is for returning. To adjust the cable play, adjust the returning cable first and then adjust the pulling cable.

#### Returning cable play

The returning cable should be adjusted to have a thread length (A) of 3–4 mm (0.12–0.16 in) as shown in the Fig. If the adjustment is necessary, adjust the thread length in the following way:

- Loosen the lock nuts ③.
- Move the adjuster ④ to obtain the thread length (A) of 3–4 mm (0.12–0.16 in).
- Tighten the lock nuts ③ securely.

#### Pulling cable play

The pulling cable should be adjusted to have a cable play (B) of 0.5–1.0 mm (0.02–0.04 in) as shown in the Fig. If the adjustment is necessary, adjust the cable play in the following way:

- Turn the handlebar all the way to the left.
- Loosen the lock nuts ⑤, ⑥.
- Turn the adjuster ⑦ or move the adjuster ⑧ to obtain the cable play (B) of 0.5–1.0 mm (0.02–0.04 in).
- Tighten the lock nuts ⑤, ⑥ securely.

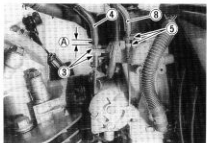
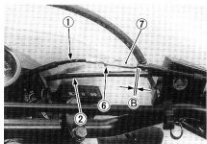

### ⚠ WARNING

After the adjustment is completed, check that handlebar movement does not raise the engine idle speed and that the throttle grip returns smoothly and automatically.

### IDLE RPM ADJUSTMENT

#### NOTE:

Make this adjustment when the engine is warm.

- Connect a tachometer.

#### 09900-26006: Tachometer

- Start up the engine and set its speed at anywhere between 1 400 and 1 600 r/min by turning the throttle stop screw ①.
- Turn in or out the pilot screw within 1/2 turn from the standard setting, and set it when the engine speed is at the highest possible level.
- After previous adjustment, recheck the idling speed and adjust to between 1 400 and 1 600 r/min with throttle stop screw if necessary.

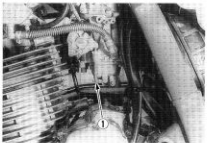

#### Engine idle speed:

- 1 500 ± 50 r/min ... for Switzerland
- 1 500 ± 100 r/min ... for the Others

**FUEL LINE (EVAP HOSE ... California model only)**

Inspect Initially at 1 000 km (600 miles, 2 months) and Every 6 000 km (4 000 miles, 12 months) thereafter.  
Replace Every 4 years.

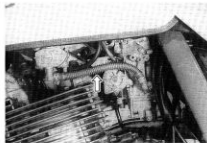
**FUEL VALVE STRAINER**

Clean Every 12 000 km (7 500 miles, 24 months).

Refer to page 4-2 for removal procedure.

**CLUTCH**

Inspect Initially at 1 000 km (600 miles, 2 months) and Every 6 000 km (4 000 miles, 12 months) thereafter.

- Loosen the lock nut ① and turn the clutch cable adjuster ② fully in.
- Loosen the lock nut ③ and turn the clutch cable adjuster ④ to provide the specified clutch lever play **A**.

Clutch lever play **A**: 10–15 mm (0.4–0.6 in)

- Tighten the lock nuts (① and ③) while holding the adjusters (② and ④) in positions.

**NOTE:**

Minor adjustment can be made by the adjuster ② after loosening the lock nut ①. At the same intervals, lubricate the clutch cable with motor oil

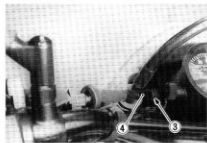
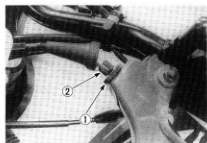

## ENGINE OIL AND OIL FILTER

**(ENGINE OIL)**

Replace (Change) Initially at 1 000 km (600 miles, 2 months) and Every 6 000 km (4 000 miles, 12 months) thereafter.

**(OIL FILTER)**

Replace Initially at 1 000 km (600 miles, 2 months) and Every 12 000 km (7 500 miles, 24 months) thereafter.

Oil should be changed while the engine is warm. Oil filter replacement at the above intervals should be done together with engine oil change.

- Keep the motorcycle upright, supported by jack or wooden block.
- Place an oil pan below the engine and remove the engine oil drain plug ① and oil filler cap ② to drain engine oil.
- Remove the oil filter cap by removing the three bolts ③.
- Remove the oil filter ④ and install the new one.
- Install the oil filter cap and tighten the bolts ③ securely.

**NOTE:**

Before installing the oil filter and oil filter cap, check to be sure that the spring ⑤ and new O-rings (⑥ and ⑦) are installed correctly and apply engine oil lightly to the new O-ring ⑥.

- Tighten the oil drain plug ① securely, and pour fresh oil through the oil filler. The engine will hold about 2 300 ml of oil. Use an API classification of SE, SF or SG oil with SAE 10W/40 viscosity.

**🔧 Drain plug: 24 N·m (2.4 kg·m, 17.5 lb·ft)**

- Install the oil filler cap ②.
- Start up the engine and allow it to run for several minutes at idling speed.
- Turn off the engine and wait about one minute, then check the oil level through the inspection window ⑧. If the level is below mark "F", add oil to the level.

**NECESSARY AMOUNT OF ENGINE OIL**

Oil change : 2 300 ml (2.4/2.0 US/Imp qt)

Filter change : 2 400 ml (2.5/2.1 US/Imp qt)

Overhaul engine: 2 600 ml (2.7/2.3 US/Imp qt)

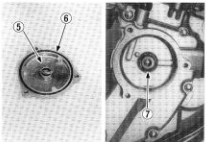
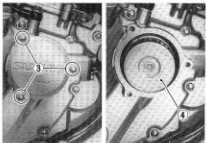
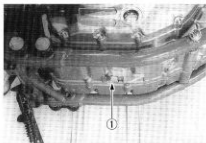

## DRIVE CHAIN

Inspect Initially at 1 000 km (600 miles, 2 months) and Every 6 000 km (4 000 miles, 12 months) thereafter.  
Clean and Lubricate Every 1 000 km (600 miles).

Visually check the drive chain for the possible defects listed below. (Support the motorcycle by a jack and a wooden block, turn the rear wheel slowly by hand with the transmission shifted to Neutral.)

- \* Loose pins
- \* Excessive wear
- \* Damaged rollers
- \* Improper chain adjustment
- \* Dry or rusted links
- \* Missing O-ring seals
- \* Kinked or binding links

If any defects are found, the drive chain must be replaced.

**NOTE:**

When replacing the drive chain, replace the drive chain and sprockets as a set.

**CHECKING**

- Remove the axle cotter pin (Canada and U.S.A).
- Loosen the axle nut ①.
- Tense the drive chain fully by turning both chain adjusters ②.
- Count out 21 pins (20 pitches) on the chain and measure the distance between the two points. If the distance exceeds the service limit, the chain must be replaced.

	Service Limit
Drive chain 20-pitch length	319.4 mm (12.6 in)

**ADJUSTING**

- Turn both chain adjusters ② until the chain has 30–45 mm (1.2–1.8 in) of slack in the middle between engine and rear sprockets. The number on both chain adjusters must be at the same number on the scale to ensure that the front and rear wheels are correctly aligned.
- Place the motorcycle on its side-stand for accurate adjustment.
- After adjusting the drive chain, tighten the axle nut ① to the specified torque.

**Ⓜ** Rear axle nut: 100 N·m (10.0 kg·m, 72.5 lb·ft)  
(with cotter pin)

Rear axle nut: 110 N·m (11.0 kg·m, 79.5 lb·ft)  
(Self-locking)

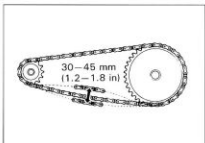
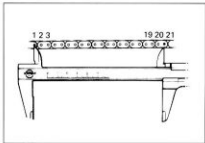
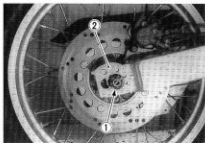
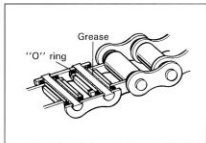

**CLEANING AND LUBRICATING**

- Wash the chain with kerosene. If the chain tends to rust quickly, the intervals must be shortened.

**CAUTION**

Do not use trichlene, gasoline or any similar fluids: These fluids have too great a dissolving power for this chain and, what is more important, they can damage the "O"-rings (or seals) confining the grease in the bush to pin clearance. Remember, high durability comes from the presence of grease in that clearance.

- After washing and drying the chain, oil it with a heavy-weight motor oil.

**CAUTION**

- Do not use any oil sold commercially as "drive chain oil". Such oil can damage the "O"-rings (or seals).
- The standard drive chain is D.I.D. 525 V<sub>9</sub>, 110 links. SUZUKI recommends that this standard drive chain should be used for the replacement.

**BRAKES****(BRAKE)**

Inspect Initially at 1 000 km (600 miles, 2 months) and Every 6 000 km (4 000 miles, 12 months) thereafter.

**(BRAKE HOSE AND BRAKE FLUID)**

Inspect Every 6 000 km (4 000 miles, 12 months). Replace hoses Every 4 years. Replace fluid Every 2 years.

**BRAKE FLUID LEVEL**

- Keep the motorcycle upright and place the handlebars straight.
- Check the brake fluid level by observing the lower limit lines on the front and rear brake fluid reservoirs.
- When the level is below the lower limit line, replenish with brake fluid that meets the following specification.

**BS** Specification and Classification: DOT 4

**WARNING**

The brake system of this motorcycle is filled with a glycol-based brake fluid. Do not use or mix different types of fluid such as silicone-based or petroleum-based. Do not use any brake fluid taken from old, used or unsealed containers. Never re-use brake fluid left over from the last servicing or stored for a long period.

**WARNING**

Brake fluid, if it leaks, will interfere with safe running and immediately discolor painted surfaces. Check the brake hoses and hose joints for cracks and oil leakage before riding.

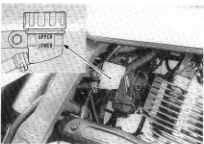

**BRAKE PADS**

The extent of brake pad wear can be checked by observing the grooved limit line ① on the pad. When the wear exceeds the grooved limit line, replace the pads with new ones. (Refer to pages 5-7 and 5-34.)

**CAUTION**

Replace the brake pad as a set, otherwise braking performance will be adversely affected.

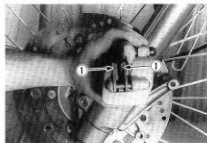
**BRAKE PEDAL HEIGHT**

- Loosen the lock nut ③ and rotate the push rod ④ to locate brake pedal 5 mm below the top face of the footrest.
- Retighten the lock nut ③ to secure the push rod ④ in the proper position.

Brake pedal height ⑤: 5 mm (0.2 in)

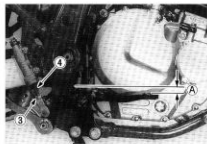
**AIR BLEEDING THE BRAKE FLUID CIRCUIT**

Air trapped in the fluid circuit acts like a cushion to absorb a large proportion of the pressure developed by the master cylinder and thus interferes with the full braking performance of the brake caliper. The presence of air is indicated by "sponginess" of the brake lever and also by lack of braking force. Considering the danger to which such trapped air exposes the machine and rider, it is essential that, after remounting the brake and restoring the brake system to the normal condition, the brake fluid circuit be purged of air in the following manner:

- Fill up the master cylinder reservoir to the "UPPER" line. Replace the reservoir cap to prevent entry of dirt.
- Attach a pipe to the caliper bleeder valve, and insert the free end of the pipe into a receptacle.

**Air bleeder valve: 8 N·m (0.8 kg·m, 6.0 lb-ft)**

- Front brake: Bleed the air from the air bleeder valve.
- Squeeze and release the brake lever several times in rapid succession and squeeze the lever fully without releasing it. Loosen the bleeder valve by turning it a quarter of a turn so that the brake fluid runs into the receptacle; this will remove the tension of the brake lever causing it to touch the handlebar grip. Then, close the valve, pump and squeeze the lever, and open the valve. Repeat this process until the fluid flowing into the receptacle no longer contains air bubbles.

**NOTE:**

Replenish the brake fluid in the reservoir as necessary while bleeding the brake system. Make sure that there is always some fluid visible in the reservoir.

- Close the bleeder valve, and disconnect the pipe. Fill the reservoir with brake fluid to the "UPPER" end of the inspection window.

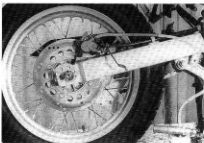
**CAUTION**

Handle brake fluid with care: the fluid reacts chemically with paint, plastics, rubber materials etc.

- The only difference between bleeding the front and rear brakes is that the rear master cylinder is actuated by a pedal.

**TIRES**

Inspect Every 6 000 km (4 000 miles, 12 months).

**TIRE TREAD CONDITION**

Operating the motorcycle with excessively worn tires will decrease riding stability and consequently invite a dangerous situation. It is highly recommended to replace a tire when the remaining depth of tire tread reaches the following specification.

**Tire tread depth limit: FRONT & REAR 3.0 mm (0.12 in)**

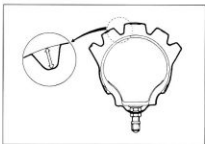

## TIRE PRESSURE

If the tire pressure is too high or too low, steering will be adversely affected and tire wear increased. Therefore, maintain the correct tire pressure for good roadability or shorter tire life will result. Cold inflation tire pressure is as follows.

COLD INFLATION TIRE PRESSURE	SOLO RIDING			DUAL RIDING		
	kPa	kg/cm <sup>2</sup>	psi	kPa	kg/cm <sup>2</sup>	psi
FRONT	150	1.50	22	175	1.75	25
REAR	175	1.75	25	200	2.00	29

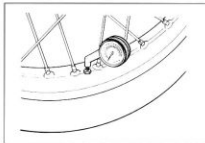

### ⚠ CAUTION

The standard tire fitted on this motorcycle is 90/90-21 54S for front and 120/90-17 64S for rear. The use of tires other than those specified may cause instability. It is highly recommended to use a SUZUKI Genuine Tire.

## SPARK ARRESTER (For U.S.A. and CANADA)

Clean Every 6 000 km (4 000 miles).

If the muffler is clogged with carbon particles, exhaust resistance will be increased with a resultant decrease in power output.

- Remove the drain plugs.
- Start the engine and rev it to blow out the accumulated carbon particles.
- Turn off the engine and wait until the muffler cools, then replace the drain plugs and tighten them securely.



## STEERING

Inspect Initially at 1 000 km (600 miles, 2 months) and Every 12 000 km (7 500 miles, 24 months) thereafter.

Taper roller type bearings are used on the steering system for better handling. Steering should be adjusted properly for smooth turning of handlebars and safe running. Overtight steering prevents smooth turning of the handlebars and too loose steering will cause poor stability. Check that there is no play in the front fork assembly by supporting the machine so that the front wheel is off the ground, with the wheel straight ahead, grasp the lower fork tubes near the axle and pull forward. If play is found, perform steering bearing adjustment as described in page 5-20 of this manual.

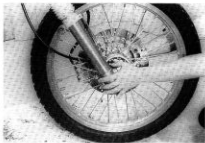



## FRONT FORKS

Inspect Every 12 000 km (7 500 miles, 24 months).

Inspect the front forks for oil leakage, scoring or scratches on the outer surface of the inner tubes. Replace any defective parts, if necessary. (Refer to page 5-14.)

## REAR SUSPENSION

Inspect Every 12 000 km (7 500 miles, 24 months).

Inspect the rear shock absorber for oil leakage and check that there is no play in the swingarm assembly.

## EXHAUST PIPE AND MUFFLER BOLTS

Tighten Initially at 1 000 km (600 miles, 2 months) and Every 12 000 km (7 500 miles, 24 months) thereafter.

- Remove the right frame cover.
- Tighten the exhaust pipe bolts ①, muffler connection bolt ② and muffler bolts ③ to the specified torque.

 Exhaust pipe bolt/Muffler connection bolt/  
Muffler bolt: 26 N·m (2.6 kg·m, 19.0 lb-ft)

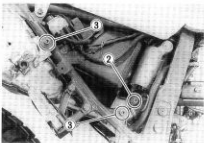
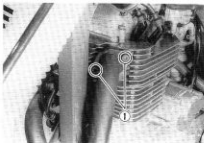

## CHASSIS BOLTS AND NUTS

**Tighten Initially at 1 000 km (600 miles, 2 months) and Every 6 000 km (4 000 miles, 12 months) thereafter.**

Check that all chassis bolts and nuts are tightened to their specified torque. (Refer to page 2-16 for the locations of the following nuts and bolts on the motorcycle.)

Item	N-m	kg-m	lb-ft
① Steering stem head nut	90	9.0	65.0
② Front fork upper clamp bolt	29	2.9	21.0
③ Front fork lower clamp bolt	26	2.6	19.0
④ Front fork cap bolt	23	2.3	16.5
⑤ Front axle	65	6.5	47.0
⑥ Front axle holder nut	10	1.0	7.0
⑦ Handlebars clamp bolt	23	2.3	16.5
⑧ Front brake master cylinder mounting bolt	10	1.0	7.0
⑨ Front brake caliper mounting bolt	26	2.6	19.0
⑩ Front brake caliper pad mounting bolt	18	1.8	13.0
⑪ Brake hose union bolt (Front & Rear)	23	2.3	16.5
⑫ Air bleeder valve (Front & Rear)	8	0.8	6.0
⑬ Brake disc bolt (Front & Rear)	23	2.3	16.5
⑭ Rear brake caliper pad mounting bolt	18	1.8	13.0
⑮ Rear brake master cylinder mounting bolt	10	1.0	7.0
⑯ Rear brake master cylinder rod lock nut	18	1.8	13.0
⑰ Front footrest bracket mounting bolt	39	3.9	28.0
⑱ Rear footrest bracket mounting bolt	23	2.3	16.5
⑲ Swingarm pivot nut	77	7.7	55.5
⑳ Rear shock absorber mounting bolt (Upper & Lower)	55	5.5	40.0
㉑ Rear cushion lever/rod mounting nut	100	10.0	72.5
㉒ Rear cushion lever mounting bolt	80	8.0	58.0
㉓ Rear axle nut (with cotter pin)	100	10.0	72.5
㉔ Rear axle nut (Self-locking)	110	11.0	79.5
㉕ Rear sprocket nut/bolt	27	2.7	19.5

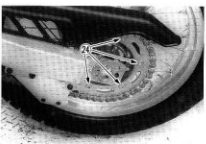
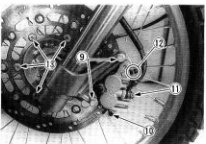
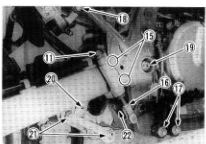
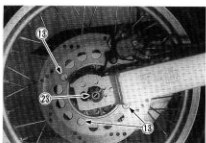
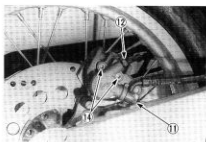
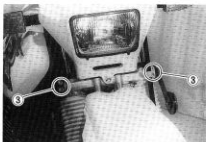
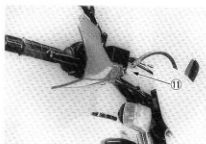
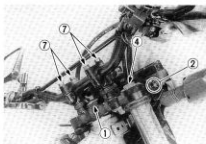

## COMPRESSION PRESSURE CHECK

The compression of a cylinder is a good indicator of its internal condition.

The decision to overhaul the cylinder is often based on the results of a compression test. Periodic maintenance records kept at your dealership should include compression readings for each maintenance service.

### COMPRESSION PRESSURE SPECIFICATION

Standard
Approx. $\left( \begin{array}{l} 850 \text{ kPa} \\ 8.5 \text{ kg/cm}^2 \\ 120 \text{ psi} \end{array} \right)$

**Low compression pressure can indicate any of the following conditions:**

- \* Excessively worn cylinder wall
- \* Worn-down piston or piston rings
- \* Piston rings stuck in grooves
- \* Poor seating of valves
- \* Ruptured or otherwise defective cylinder head gasket

## COMPRESSION TEST PROCEDURE

### NOTE:

- \* *Before testing the engine for compression pressure, make sure that the cylinder head bolts are tightened to the specified torque values and valves are properly adjusted.*
- \* *Have the engine warmed up by idling before testing.*
- \* *Be sure that the battery used is in fully-charged condition.*

Remove the parts concerned and test the compression pressure in the following manner.

- Remove the spark plug.
- Fit the compression gauge in the plug hole, while taking care that the connection tight.
- Keep the throttle grip in full-open position.
- While cranking the engine a few seconds with the starter, and record the maximum gauge reading as the compression of that cylinder.



**09915-64510: Compression gauge**

**09915-63310: Adaptor**

## OIL PRESSURE CHECK

Check periodically the oil pressure in the engine to judge roughly the condition of the moving parts.

### OIL PRESSURE SPECIFICATION

<p><b>Above 30 kPa (0.3 kg/cm<sup>2</sup>, 4.3 psi)</b>  <b>Below 70 kPa (0.7 kg/cm<sup>2</sup>, 10 psi)</b></p>	<p><b>at 3 000 r/min., Oil temp. at 60°C (140°F)</b></p>
--	--

If the oil pressure is lower or higher than the specification, the following causes may be considered.

#### LOW OIL PRESSURE

- \* Oil leakage from the oil passage way
- \* Damaged O-ring
- \* Defective oil pump
- \* Combination of above items

#### HIGH OIL PRESSURE

- \* Used a engine oil which is too high viscosity
- \* Clogged oil passage way
- \* Combination of above items

### OIL PRESSURE TEST PROCEDURE

Check the oil pressure in the following manner.

- Remove the oil pressure inspection plug.
- Install the oil pressure gauge in the position shown in the figure.
- Warm up the engine as follows:  
 Summer 10 min. at 2 000 r/min.  
 Winter 20 min. at 2 000 r/min.
- After warming up, increase the engine speed to 3 000 r/min. (with the engine tachometer), and read the oil pressure gauge.

 **09915-74510: Oil pressure gauge**  
**09900-26006: Tachometer**



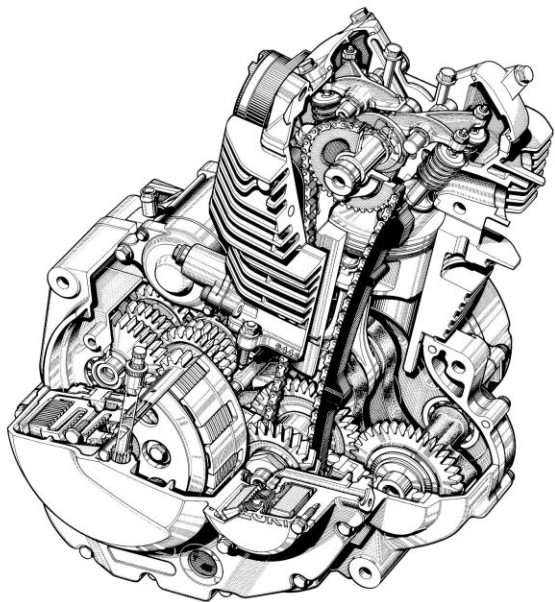

# ENGINE

## CONTENTS

<b>ENGINE COMPONENTS REMOVABLE WITH THE ENGINE IN PLACE</b> .....	<b>3- 1</b>
<b>ENGINE REMOVAL AND REINSTALLATION</b> .....	<b>3- 2</b>
<b>ENGINE REMOVAL</b> .....	<b>3- 2</b>
<b>ENGINE REINSTALLATION</b> .....	<b>3- 6</b>
<b>ENGINE DISASSEMBLY</b> .....	<b>3- 9</b>
<b>ENGINE COMPONENTS INSPECTION AND SERVICE</b> .....	<b>3-17</b>
<b>CYLINDER HEAD COVER</b> .....	<b>3-17</b>
<b>ROCKER ARM</b> .....	<b>3-18</b>
<b>CYLINDER HEAD</b> .....	<b>3-19</b>
<b>VALVE</b> .....	<b>3-20</b>
<b>CAMSHAFT/AUTOMATIC DE-COMP. ASSEMBLY</b> .....	<b>3-25</b>
<b>CYLINDER</b> .....	<b>3-27</b>
<b>PISTON</b> .....	<b>3-27</b>
<b>PISTON RING</b> .....	<b>3-28</b>
<b>CONROD</b> .....	<b>3-29</b>
<b>CRANKSHAFT</b> .....	<b>3-30</b>
<b>BALANCERSHAFT AND GEAR</b> .....	<b>3-31</b>
<b>CLUTCH</b> .....	<b>3-32</b>
<b>STARTER CLUTCH</b> .....	<b>3-34</b>
<b>TRANSMISSION</b> .....	<b>3-36</b>
<b>OIL NOZZLE AND OIL JET</b> .....	<b>3-40</b>
<b>CRANKCASE BEARINGS</b> .....	<b>3-40</b>
<b>OIL FILTER</b> .....	<b>3-41</b>
<b>GENERATOR</b> .....	<b>3-41</b>
<b>ENGINE REASSEMBLY</b> .....	<b>3-42</b>

## ENGINE COMPONENTS REMOVABLE WITH THE ENGINE IN PLACE

The parts listed below can be removed and reinstalled without removing the engine from the frame. Refer to the page listed in each section for removal and reinstallation instructions.

### ENGINE CENTER

	Refer to page
Cam drive chain tensioner .....	3- 9 and 57
Cylinder head cover .....	3-10 and 56
Camshaft/auto-decompression .....	3-10 and 55
Cylinder head .....	3-10 and 54
Cylinder .....	3-11 and 54
Piston .....	3-11 and 53
Starter motor .....	3-11 and 52
Cam drive chain .....	3-14 and 48

### ENGINE LEFT SIDE

	Refer to page
Engine sprocket .....	3- 5 and 7
Generator cover .....	3- 9 and 52
Starter torque limiter .....	3-11 and 52
Starter idle gear .....	3-11 and 52
Generator rotor .....	3-11 and 51
Starter clutch .....	3-34 and 35
Starter gear .....	3-12 and 51
Gearshift shaft .....	3-13 and 47
Gearshift cam pawl and cam driven gear .....	3-13 and 46

### ENGINE RIGHT SIDE

	Refer to page
Clutch cover .....	3-13 and 50
Clutch .....	3-13 and 49
Primary driven gear .....	3-14 and 49
Primary drive gear .....	3-14 and 48
Oil pump driven gear .....	3-14 and 48
Oil pump assembly .....	3-14 and 48
Neutral position indicator switch .....	3-14 and 47
Oil filter .....	3-41



## ENGINE REMOVAL AND REINSTALLATION

### ENGINE REMOVAL

Before taking the engine out of the frame, thoroughly clean the engine with a suitable cleaner. The procedure of engine removal is sequentially explained in the following steps:

- Remove the oil drain plug ① to drain out engine oil.
- Remove the frame covers. (Refer to page 5-1.)
- Remove the seat. (Refer to page 5-1.)
  
- Remove the battery holder plate ②.
  
- Disconnect the battery  $\ominus$  lead wire ③ from the battery terminal.
- Remove the fuel tank. (Refer to page 4-3.)
  
- Remove the oil cooler hose mounting bolts.
  
- Remove the oil cooler holder with cooler by removing the mounting bolts.

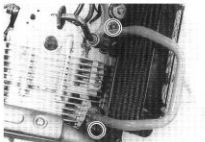
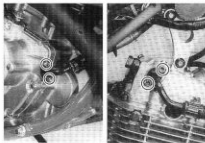
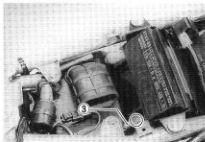
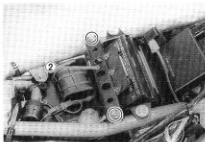
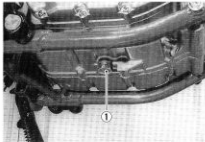

### 3-3 ENGINE

- Remove the exhaust pipe bolts.

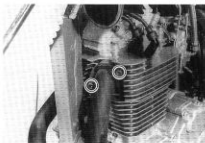

- Remove the exhaust pipe by loosening the connection bolt.

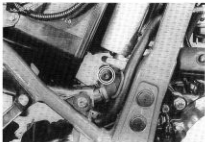

- Disconnect the pick-up coil/power source coil lead wire coupler ①.

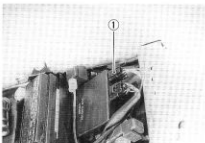

- Disconnect the generator coil and neutral position indicator switch lead wires.

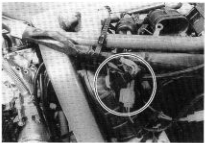

- Disconnect the spark plug caps.

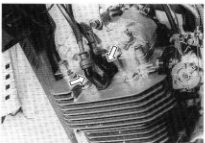

- Disconnect the throttle cables and starter (choke) cable.
- Disconnect the air vent hose.

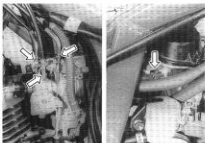

- Remove the carburetor by loosening the mounting clamp screws.

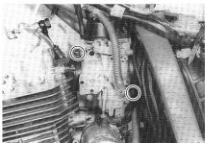

- Disconnect the clutch cable by removing the cable lever.



- Disconnect the starter motor lead wire ① and crankcase breather hose ②.

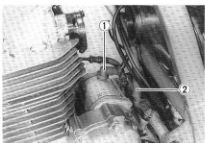

- Remove the left front footrest ③.
- Remove the engine sprocket cover ④ and gearshift lever ⑤.

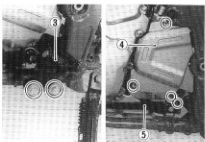

### 3-5 ENGINE

- Remove the engine sprocket bolts while depressing the rear brake pedal.
- Remove the engine sprocket.

**NOTE:**

*If it is difficult to remove the engine sprocket, loosen the rear axle nut and then adjust the chain adjusters to provide additional chain slack.*

- Remove the engine ground wire and lead wire clamp.



- Remove the engine mounting nuts, bolts, spacers and brackets.

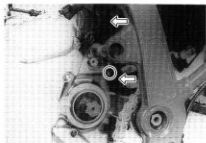

- Remove the engine through the left side of the frame.

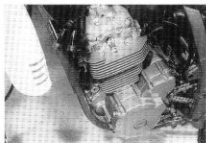
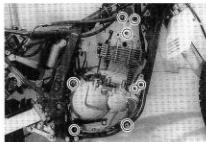

## ENGINE REINSTALLATION

Reinstall the engine in the reverse order of engine removal.

- Insert the two long bolts from left side. Install the brackets, spacers, bolts and nuts properly, as shown in the following illustration.

### NOTE:

The engine mounting nuts are self-locking. Once the nut has been removed, it is no longer of any use. Be sure to use new nuts and tighten them to the specified torque.

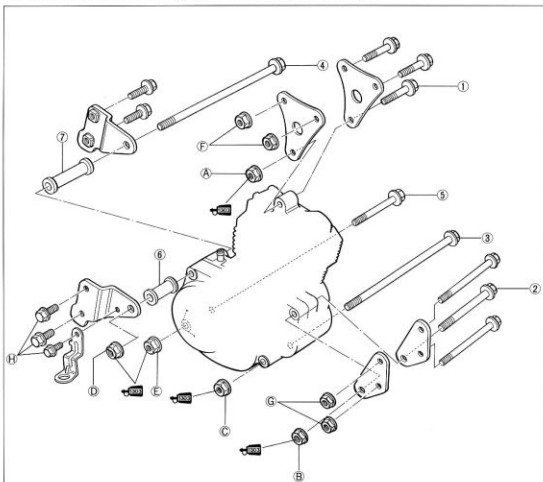

ITEM	N·m	kg·m	lb·ft
A	40	4.0	29.0
B C D E	65	6.5	47.0
F G	40	4.0	29.0
H	23	2.3	16.5

### LENGTH

Bolt ①	53 mm (2.1 in)
Bolt ②	100 mm (3.9 in)
Bolt ③	235 mm (9.3 in)
Bolt ④	235 mm (9.3 in)
Bolt ⑤	130 mm (5.1 in)
Spacer ⑥	27 mm (1.1 in)
Spacer ⑦	65 mm (2.6 in)

- Apply THREAD LOCK SUPER "1303" to the engine sprocket mounting bolts and tighten them to the specified torque.

 99000-32030: THREAD LOCK SUPER "1303"

 Engine sprocket bolt: 6 N·m (0.6 kg-m, 4.5 lb-ft)



- Install the oil cooler hoses to the clutch cover and cylinder head correctly.

**CAUTION**

Replace the O-rings  with new one to prevent oil leakage.

- Tighten the oil cooler hose securing bolts to the specified torque.

 Oil cooler hose bolt: 10 N·m (1.0 kg-m, 7.0 lb-ft)

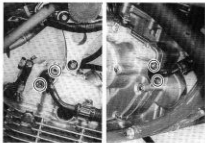
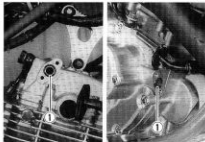

- Tighten the front footrest bolts to the specified torque.

 Front footrest bolt: 39 N·m (3.9 kg-m, 28.0 lb-ft)



- After remounting the engine, route the wiring harnesses, cables and hoses properly by referring to the sections, for wire routing, cable routing and hose routing. (Refer to pages 7-12 through 7-18.)

- Adjust the following items to the specification.
  - \* Throttle cable play ..... (Refer to page 2-6.)
  - \* Idling adjustment ..... (Refer to page 2-6.)
  - \* Clutch cable play ..... (Refer to page 2-7.)
  - \* Drive chain slack ..... (Refer to page 2-9.)
  
- Pour 2.6 L (2.7/2.3 US/Imp qt) of engine oil SAE 10W/40 graded SE, SF or SG into the engine after overhauling engine.
- Start up the engine and allow it run for several minutes at idle speed. About five minutes after stopping engine, check oil level.  
If the level is below the "F" mark, add oil until the level reaches the "F" mark.



Change	2 300 ml (2.4/2.0 US/Imp qt)
Filter change	2 400 ml (2.5/2.1 US/Imp qt)
Overhaul	2 600 ml (2.7/2.3 US/Imp qt)

## ENGINE DISASSEMBLY

- Remove the oil pipe by removing the mounting bolts.
- Remove the cam drive chain tensioner by removing the bolts.
- Remove the two spark plugs.
- Remove the generator cover by removing the bolts.

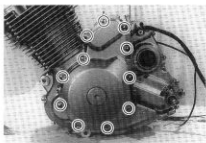
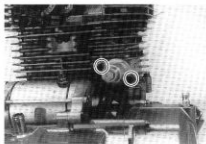
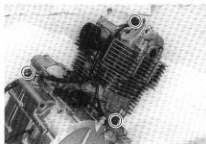

**NOTE:**

When removing the cylinder head cover, the piston must be at top dead center on the compression stroke.

Align "TOP" line ① on the generator rotor with index mark ② on the crankcase.

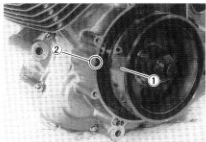



- Remove the valve inspection caps (Intake and Exhaust) by removing the bolts.

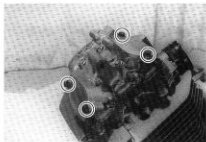

- Loosen the cylinder head cover bolts in the ascending order numbers and remove the cylinder head cover.

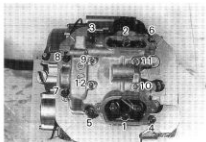

- Flatten the lock washer and remove the camshaft sprocket bolts.
- Remove the sprocket and camshaft/auto-decompression assembly.

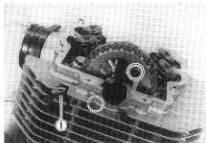
**NOTE:**

The cam chain tensioner bolt ① is to be removed only when disassembling the engine.

 <b>CAUTION</b>
--

<p>Do not drop camshaft drive chain, pin, C-ring or sprocket into the crankcase.</p>
--

- Remove the cylinder head by removing the bolts and nuts diagonally.

**NOTE:**

If it is difficult to remove the cylinder head, gently pry it off while tapping the finless portion of the cylinder head with a plastic hammer. Be careful not to break the fins.

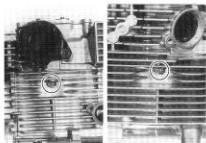
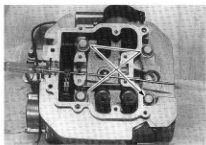

- Remove the cylinder by removing the nuts.

**CAUTION**

If tapping with a plastic hammer is necessary, do not break the fins.

- Place a clean rag over the cylinder base to prevent the piston pin circlips from dropping into crankcase. Remove the piston pin circlips with a long-nose pliers.
- Remove the piston by removing the piston pin.

- Remove the clutch cable holder and starter motor.

- Remove the starter torque limiter ① and starter idle gear ② with shaft.

- Loosen the generator rotor bolt with the 36 mm offset wrench.

**NOTE:**

Do not remove the generator rotor bolt after loosening the bolt. The generator rotor bolt is used in conjunction with the rotor remover, when removing the generator rotor.

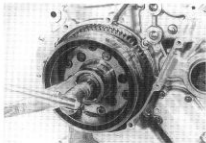
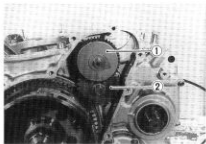

- Remove the generator rotor with the special tool.

 09930-33720: Rotor remover

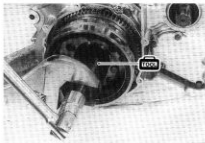

- Remove the key ①.
- Remove the starter gear ②.
- Remove the thrust washer ③.

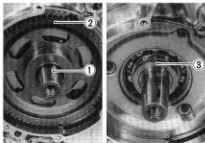

- Remove the ring nut with the special tools, then remove the spacer.

 09917-23711: Ring nut socket wrench  
09910-20116: Conrod holder

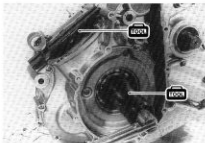

- Remove the crankcase oil separator ④ by removing the screws.
- Remove the spacer ⑤.

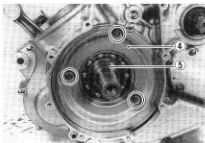

- Remove the gearshift cover by removing the bolts.

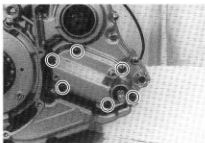

- Extract the gearshift shaft (1) and remove the cam driven gear (2) by removing the screws (3).

**NOTE:**

When removing the cam driven gear, do not lose gearshift pawl (4), pin (5) and spring (6).

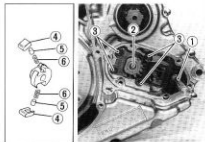

- Remove the clutch cover by removing the bolts.

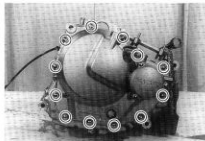

- Remove the clutch pressure plate by removing the bolts diagonally.

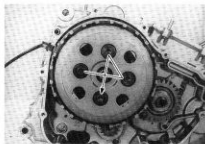

- Remove the clutch drive and driven plates.

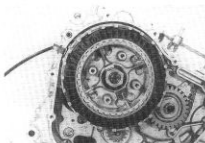

- Flatten the lock washer and remove the clutch sleeve hub nut with the special tool.

 09920-53740: Clutch sleeve hub holder

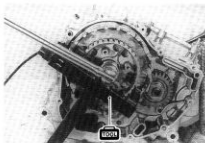

- Remove the thrust washer ① and primary driven gear assembly.
- Remove the thrust washer ②.

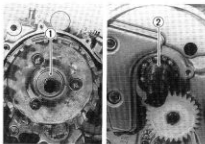

- Remove the primary drive gear nut with the special tool.

**LECO** 09910-20116: Conrod holder

**CAUTION**

This nut has left-hand thread nut.

- Remove the cam drive chain ③ and key ④.

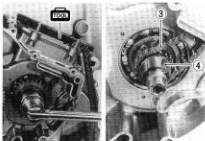

- Remove the idle gear and oil pump driven gear by removing the circlips.

**LECO** 09900-06107: Snap ring pliers

- Remove the oil pump by removing the mounting screws.

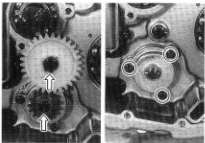

- Remove the breather cover.

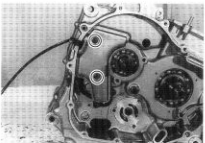

- Remove the neutral position indicator switch.

**NOTE:**

Do not loose the switch contact ⑤ and spring ⑥.

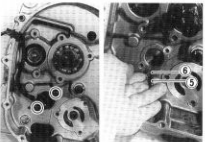

- Remove the crankcase securing bolts.
- Separate the crankcase into 2 parts, right and left with the crankcase separating tools.

**TOOL** 09920-13120: Crankcase separating tool  
 09910-33210: Crankshaft installer attachment

**NOTE:**

*Fit the crankcase separating tool, so that the tool plate is parallel with the end face of the crankcase.*

**CAUTION**

The crankshaft and transmission components must remain in the right crankcase half. This is necessary because the gearshift cam stopper is mounted on the right crankcase half and will be damaged if the transmission components remain in the left half.

- Remove the gearshift cam stopper.

- Remove the gearshift fork shafts and gearshift forks.
- Remove the gearshift cam.

- Remove the driveshaft assembly and countershaft assembly.

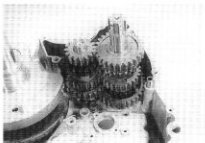
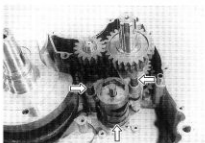
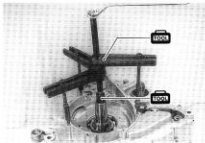
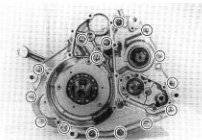

- Align the punched marks on the balancer drive gear and driven gear.
- Remove the balancershaft assembly.

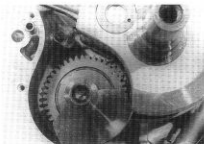

- Remove the crankshaft from the crankcase by using a crankshaft remover.

 09920-13120: Crankshaft remover  
(Crankcase separating tool)

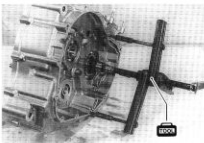

- Remove the oil sump filter cover ① by removing the bolts.
- Remove the oil sump filter ②.

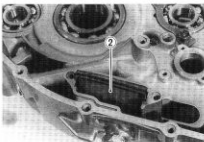
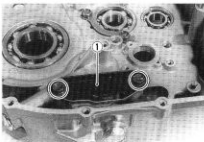

## ENGINE COMPONENTS INSPECTION AND SERVICE

### CYLINDER HEAD COVER SERVICE

**CAUTION**

Be sure to identify each removed part as to its location, and lay the parts out in groups designated as "Exhaust", "Inlet", so that each will be restored to the original location during assembly.

- Remove the intake and exhaust rocker arm shaft set bolts.

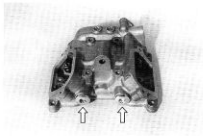

- Remove the intake and exhaust rocker arm shafts with a 6 mm bolt.





## CYLINDER HEAD COVER DISTORTION

After removing sealant from the fitting surface of the cylinder head cover, place the cylinder head cover on a surface plate and check for distortion with a thickness gauge.

**Service Limit: 0.05 mm (0.002 in)**

If the distortion exceeds the limit, replace the cylinder head cover.



## ROCKER ARM SHAFT O.D.

Measure the diameter of rocker arm shaft with a micrometer.

**Standard: 11.973–11.984 mm (0.4714–0.4718 in)**

 09900-20205: Micrometer (0–25 mm)



## ROCKER ARM I.D.

When checking the rocker arm, the inside diameter of the rocker arm and wear of the camshaft contacting surface should be checked.

**Standard: 12.000–12.018 mm (0.4724–0.4731 in)**

 09900-20605: Dial calipers

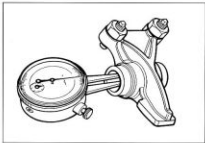

## ROCKER ARM AND SHAFT REASSEMBLY

- Apply SUZUKI MOLY PASTE to the rocker arm shafts.

 099000-25140: SUZUKI MOLY PASTE

- Install the rocker arms and shafts as shown in the illustration.

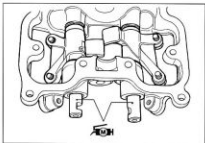

- Tighten the rocker arm shaft set bolts ① to the specified torque.

 Set bolt ①: 28 N·m (2.8 kg·m, 20.0 lb-ft)

### NOTE:

Use new gasket on the set bolts ①.

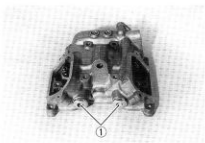

## CYLINDER HEAD SERVICE

- Remove the cam chain tensioner by removing the bolt.

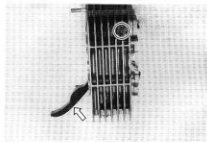

- Compress the springs with the special tools.
- Remove the valve cotters from the valve stem.

**LOCK** 09916-14510: Valve spring compressor  
 09916-14910: Valve spring compressor attachment  
 09916-84511: Tweezers

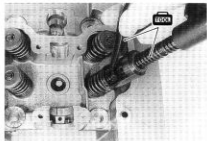

- Remove the valve spring retainer, inner spring and outer spring.
- Remove the valve stem from the other side.

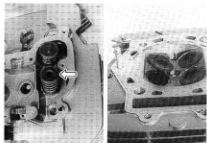

- Remove the oil seal with a long-nose pliers.
- Remove the spring seat.

### NOTE:

Removal of the valves completes ordinary disassembling work. If valve guides have to be removed for replacement after inspecting related parts, carry out the steps shown in valve guide servicing.

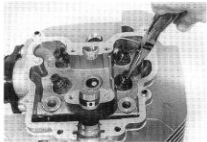

## CYLINDER HEAD DISTORTION

Decarbonize the combustion chamber.

Check the gasketed surface of the cylinder head for distortion with a straightedge and thickness gauge, taking a clearance reading at several places as indicated. If the largest reading at any position of the straightedge exceeds the limit, replace the cylinder head.

**Service Limit: 0.05 mm (0.002 in)**

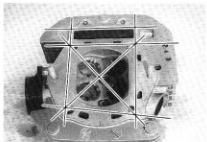

## VALVE FACE WEAR

Measure the thickness  $\text{①}$  and, if the thickness is found to have been reduced to the limit, replace the valve.

### NOTE:

Visually inspect each valve for wear of its seating face. Replace any valve with an abnormally worn face.

**Service Limit:** 0.5 mm (0.02 in)

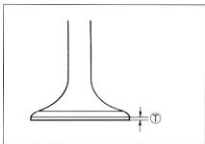

## VALVE STEM RUNOUT

Support the valve with "V" blocks, as shown, and check its runout with a dial gauge. The valve must be replaced if the runout exceeds the limit.

**Service Limit:** 0.05 mm (0.002 in)

-  09900-20701: Magnetic stand
- 09900-20606: Dial gauge (1/100 mm)
- 09900-21304: V-block (100 mm)

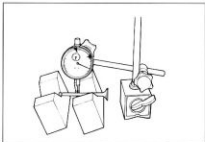

## VALVE HEAD RADIAL RUNOUT

Place the dial gauge at right angles to the valve head, and measure the valve head radial runout. If it measures more than limit, replace the valve.

**Service Limit:** 0.03 mm (0.001 in)

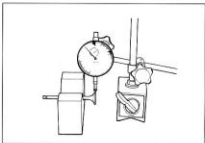

## VALVE STEM DEFLECTION

Lift the valve about 10 mm (0.39 in) from the valve seat. Measure the deflection in two directions, "X" and "Y" perpendicular to each other, by positioning the dial gauge as shown. If the deflection measured exceeds the limit specified below, then determine whether the valve or the guide should be replaced with a new one.

-  09900-20606: Dial gauge (1/100 mm)
- 09900-20701: Magnetic stand

### Service Limit

Intake and exhaust valves: 0.35 mm (0.014 in)

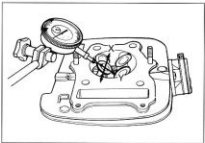

## VALVE STEM WEAR

If the valve stem is worn down to the limit, when measured with a micrometer, where the clearance is found to be in excess of the limit indicated, replace the valve; if the stem is within the limit, then replace the guide. After replacing valve or guide, be sure to recheck the clearance.

**Tools** 09900-20205: Micrometer (0–25 mm)

### Standard

IN.: 5.475–5.490 mm (0.2156–0.2161 in)

EX.: 5.455–5.470 mm (0.2148–0.2154 in)

## VALVE GUIDE SERVICING

- Remove the valve guide toward the camshaft side with the valve guide remover.

**Tools** 09916-44910: Valve guide remover/installer

### NOTE:

- Discard the removed valve guide subassemblies.
- Only oversized valve guides are available as replacement part. (Part No. 11115-32E70.)

- Re-finish the valve guide holes in cylinder head with the reamer ① and handle ②.

**Tools** 09916-34580: Valve guide reamer

09916-34541: Reamer handle

- Fit a ring to each valve guide. Be sure to use new rings and valve guides.
- Oil the stem hole, too, of each valve guide and drive the guide into the guide hole with the valve guide installer.

**Tools** 09916-44910: Valve guide remover/installer

### CAUTION

Failure to oil the valve guide hole before driving the new guide into place may result in a damaged guide or head.

- After fitting the valve guides, re-finish their guiding bores with the reamer ③ and handle ②. Be sure to clean and oil the guides after reaming.

**Tools** 09916-34550: Valve guide reamer

09916-34541: Reamer handle

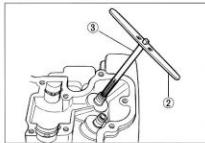
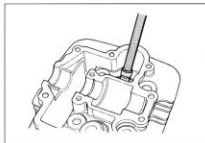
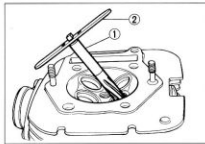
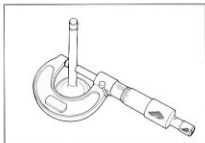

## VALVE SEAT WIDTH

- Coat the valve seat uniformly with Prussian blue. Fit the valve and tap the coated seat with the valve face in a rotating manner, in order to obtain a clear impression of the seating contact. In this operation, use the valve lapper to hold the valve head.
- The ring-like dye impression left on the valve face must be continuous-without any break. In addition, the width of the dye ring, which is the visualized seat "width", must be within the specification.

### Standard

Valve seat width  $\text{W}$ : 0.9–1.1 mm (0.035–0.043 in)

If either requirement is not met, correct the seat by servicing it as follows.

## VALVE SEAT SERVICING

The valve seats for both intake and exhaust valves are machined to two different angles. (The seat contact surface is cut 45°.)

	INTAKE	EXHAUST
45°	N-615	N-615
15°	N-615	N-121

(For U.S.A.)

Valve seat cutter (N-615)
Valve seat cutter (N-121)
Solid pilot (N-140-7.0)

(For the Others)

-  09916-24900: Valve seat cutter set  
 09916-20610: Valve seat cutter (N-121)  
 09916-24210: Valve seat cutter (N-615)  
 (N-140-7.0) : Solid pilot

### NOTE:

The valve seat contact area must be inspected after each cut.

- Insert the solid pilot with a slight rotation, seat the pilot snugly. Install the 45° cutter and T-handle.
- Using the 45° cutter, descale and clean up the seat with one or two turns.
- Inspect the seat by the previously described seat width measurement procedure. If the seat is pitted or burned, additional seat conditioning with the 45° cutter is required.

### NOTE:

Cut the minimum amount necessary from the seat to prevent the possibility of the valve stem becoming too close to the rocker arm for correct valve contact angle.

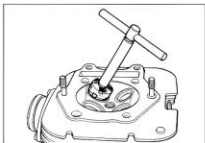
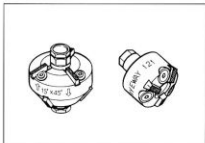
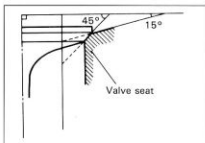
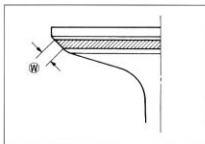

### 3-23 ENGINE

If the contact area is too high on the valve, or if it is too wide, use the 15° cutter to lower and narrow the contact area.

Contact area too high and too wide on face of valve

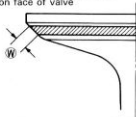

If the contact area is too low or too narrow, use the 45° cutter to raise and widen the contact area.

Contact area too low and too narrow on face of valve

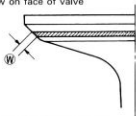

- After the desired seat position and width is achieved, use the 45° cutter very lightly to clean up and burrs caused by the previous cutting operations.

#### **CAUTION**

**DO NOT** use lapping compound after the final cut is made. The finished valve seat should have a velvety smooth finish and not a highly polished or shiny finish. This will provide a soft surface for the final seating of the valve which will occur during the first few seconds of engine operation.

- Clean and assemble the head and valve components. Fill the intake and exhaust ports with gasoline to check for leaks. If any leaks occur, inspect the valve seat and face for burrs or other things that could prevent the valve from sealing.

#### **WARNING**

Always use extreme caution when handling gasoline.

#### **NOTE:**

After servicing the valve seats, be sure to check the valve clearance after the cylinder head has been reinstalled. (Refer to page 2-3.)

## VALVE STEM END CONDITION

Inspect the valve stem end face for pitting and wear. If pitting or wear of the stem end face are present, the valve stem end should be resurfaced, providing that the length ① will not be reduced to less than 2.7 mm (0.11 in). If this length becomes less than 2.7 mm (0.11 in), the valve should be replaced. After installing a valve whose stem end has been ground off as above, check to ensure that the face ② of the valve stem end is above the cotters ③.

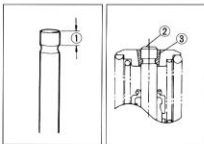

## VALVE SPRING

The force of the coil spring keeps the valve seat tight. Weakened spring result in reduced engine power output, and often account for the chattering noise coming from the valve mechanism.

Check the springs for proper strength by measuring their free length and also by the force required to compress them. If the spring length is less than the service limit, or if the force required to compress the spring does not fall within the range specified, replace both inner and outer springs as a set.

 09900-20102: Vernier calipers

Valve spring free length

Service Limit

INNER : 34.4 mm (1.35 in)

OUTER : 38.1 mm (1.50 in)

Valve spring tension

Standard

INNER : 5.9–6.7 kg/27.5 mm (13.0–14.8 lbs/1.1 in)

OUTER : 13.8–15.8 kg/31.0 mm (30.4–34.8 lbs/1.2 in)

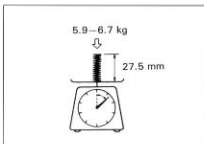
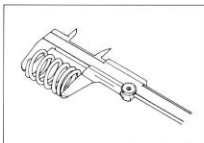

## VALVE AND VALVE SPRING REASSEMBLY

- Install the valve spring seat ①. Be careful not to confuse the lower seat with the spring retainer ②.

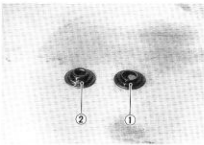

- Lubricate each seal with oil, and fit the seals onto each guide.

### CAUTION

Do not reuse the oil seals.

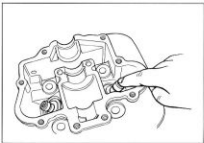

- Insert the valves, with their stems coated with (SUZUKI MOLY PASTE) all around and along the full stem length without any break.  
Similarly oil the lip of the stem seal.

 H99000-25140: SUZUKI MOLY PASTE

**CAUTION**

When inserting each valve, take care not to damage the lip of the stem seal.

- Install the valve springs, making sure that the close-pitch end ① of each spring goes in first to rest on the head. The coil pitch of both inner and outer springs vary: the pitch decreases from top to bottom, as shown in the illustration.

- Put on the valve spring retainer, and using the valve lifter, press down the springs, fit the cotter halves to the stem end, and release the lifter to allow the cotter ② to wedge in between retainer and stem. Be sure that the rounded lip ③ of the cotter fits snugly into the groove ④ in the stem end.

 09916-14510: Valve spring compressor  
09916-14910: Valve spring compressor attachment  
09916-84511: Tweezers

**CAUTION**

Be sure to locate each spring and valve to their original positions.

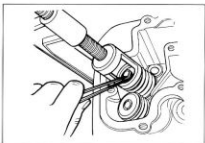
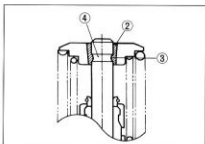
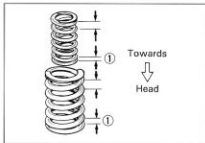
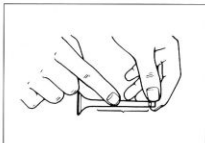

## CAMSHAFT/AUTOMATIC DE-COMP. ASSEMBLY

**CAUTION**

Do not attempt to disassemble the camshaft/automatic de-comp. assembly. It is not serviceable.





## AUTOMATIC DE-COMP.

Move the automatic de-comp. weight by hand to inspect if operating smoothly.

If it does not smoothly must be replaced with a new camshaft/automatic de-comp. assembly.



## CAMSHAFT

The camshaft should be checked for runout and also for wear of cams and journals if the engine has been noted to produce abnormal noise or vibration or to lack output power. Any of these malconditions could be caused by a worn camshaft.

### CAMSHAFT CAM WEAR

Worn-down cams are often the cause of mistimed valve operation resulting in reduced output power.

The limit of cam wear is specified for both intake and exhaust cams in terms of cam height  $\text{H}$ , which is to be measured with micrometer.

Replace the camshaft if found it worn down to the limit.

 09900-20202: Micrometer (25–50 mm)

Cam height  $\text{H}$

Service Limit Intake cam : 33.410 mm (1.3154 in)

Exhaust cam: 33.400 mm (1.3150 in)

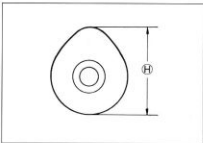

### CAMSHAFT JOURNAL WEAR

Determine whether each journal is worn down to the limit or not by measuring camshaft journal oil clearance with the camshaft installed. Use plastigauge to read the clearance, which is specified as follows:

Camshaft journal oil clearance

Service Limit: 0.150 mm (0.0059 in)

- Tighten the cylinder head cover bolts evenly and diagonally to the specified torque.

 Cylinder head cover bolt: 10 N·m (1.0 kg·m, 7.0 lb·ft)

 09900-22301: Plastigauge

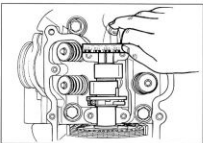

#### NOTE:

To properly measure the oil clearance with plasti-gauge, all gasket material must be removed from fitting surfaces of cylinder head and cover. Do not apply SUZUKI BOND No. 1207B until after the oil clearance has been determined.

If the camshaft journal oil clearance measured exceeds the limit, measure the outside diameter of camshaft.

Replace either the cylinder head set or the camshaft if the clearance is incorrect.

 09900-20205: Micrometer (0–25 mm)

Camshaft journal O.D.: 21.959–21.980 mm  
(Right & Center) (0.8645–0.8654 in)

Camshaft journal O.D.: 17.466–17.484 mm  
(Left) (0.6877–0.6883 in)

### CAMSHAFT RUNOUT

Measure the runout with a dial gauge. Replace the camshaft if the runout exceeds the limit.

Service Limit: 0.10 mm (0.004 in)

 09900-20701: Magnetic stand  
09900-20606: Dial gauge (1/100 mm)  
09900-21304: V-block

### CYLINDER DISTORTION

Check the gasketed surface of the cylinder for distortion with a straightedge and thickness gauge, taking a clearance reading at several places as indicated. If the largest reading at any position of the straightedge exceeds the limit, replace the cylinder.

Service Limit: 0.05 mm (0.002 in)

### CYLINDER BORE

Inspect the cylinder wall for nicks, scratches or other damage.

 09900-20508: Cylinder bore gauge set  
09900-20513: Gauge rod

Standard: 100.000–100.015 mm (3.9370–3.9376 in)

### PISTON DIAMETER

Using a micrometer, measure the piston outside diameter at the place 21 mm (0.8 in) from the skirt end as shown in Fig. If the measurement is less than the limit, replace the piston.

 09900-20204: Micrometer (75–100 mm)

Service Limit: 99.880 mm (3.9323 in)

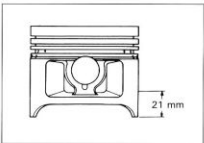
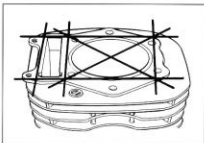
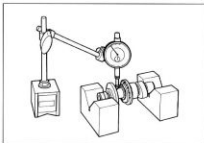
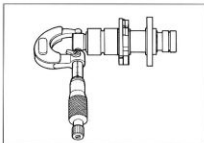

## PISTON—CYLINDER CLEARANCE

As a result of the previous measurement, if the piston to cylinder clearance exceeds the limit, replace both cylinder and piston.

**Service Limit: 0.120 mm (0.0047 in)**

## PISTON RING—GROOVE CLEARANCE

Using a thickness gauge, measure the side clearance of the 1st and 2nd rings. If any of the clearances exceeds the limit, replace both piston and piston rings.

**09900-20803: Thickness gauge**  
**09900-20205: Micrometer (0–25 mm)**

**Piston ring—groove clearance**

**Service Limit**

**1st : 0.180 mm (0.0071 in)**

**2nd: 0.150 mm (0.0059 in)**

**Piston ring groove width**

**Standard**

**1st : 1.23–1.25 mm (0.048–0.049 in)**

**2nd: 1.21–1.23 mm (0.047–0.048 in)**

**Oil : 2.81–2.83 mm (0.110–0.111 in)**

**Piston ring thickness**

**Standard**

**1st : 1.170–1.190 mm (0.0461–0.469 in)**

**2nd: 1.150–1.170 mm (0.0453–0.0461 in)**

### NOTE:

Using a soft-metal scraper, decarbon the crown of the piston. Clean the ring grooves similarly.

## PISTON RING FREE END GAP AND PISTON RING END GAP

Before installing piston rings, measure the free end gap of each ring using vernier calipers.

Next, fit the ring in the cylinder, and measure each ring end gap using a thickness gauge.

If any ring has an excess end gap, replace the ring.

**09900-20102: Vernier calipers**

**Piston ring free end gap**

**Service Limit**

**1st : 10.8 mm (0.43 in)**

**2nd: 9.1 mm (0.36 in)**

**09900-20803: Thickness gauge**

**Piston ring end gap**

**Service Limit**

**1st: 0.50 mm (0.020 in)**

**2nd: 1.00 mm (0.039 in)**

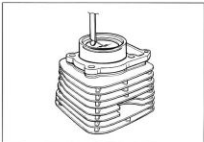
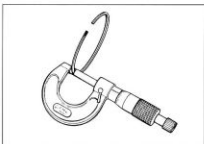

## PISTON PIN AND PIN BORE

Using a caliper gauge, measure the piston pin bore inside diameter, and using a micrometer measure the piston pin outside diameter. If the difference between these two measurements is more than the limits, replace both piston and piston pin.

 09900-20605: Dial calipers  
09900-20205: Micrometer (0–25 mm)

**Piston pin bore**

**Service Limit: 23.030 mm (0.9067 in)**

**Piston pin O.D.**

**Service Limit: 22.980 mm (0.9047 in)**

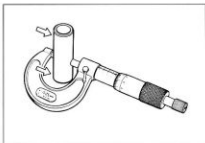
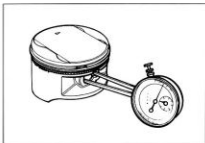

## CONROD SMALL END I.D.

Using a caliper gauge, measure the conrod small end inside diameter.

 09900-20605: Dial calipers

**Service Limit: 23.040 mm (0.9071 in)**

If the conrod small end bore inside diameter exceeds the limit, replace conrod.

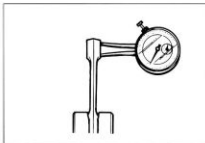

## CONROD DEFLECTION AND CONROD BIG END SIDE CLEARANCE

Wear on the big end of the conrod can be estimated by checking the movement of the small end of the rod. This method can also check the extent of wear on the parts of the conrod's big end.

 09900-20701: Magnetic stand  
09900-20606: Dial gauge (1/100 mm)  
09900-21304: V-block

**Service Limit: 3.0 mm (0.12 in)**

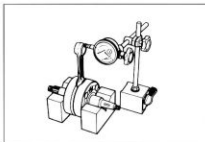

Push the big end of the conrod to one side and measure the side clearance with a thickness gauge.

 09900-20803: Thickness gauge

**Service Limit: 1.00 mm (0.039 in)**

Where the limit is exceeded, replace crankshaft assembly or reduce the deflection and the side clearance to within the limit by replacing the worn parts—conrod, big end bearing and crank pin etc.

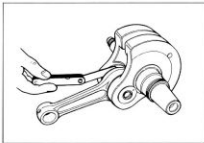

### CRANKSHAFT RUNOUT

Support the crankshaft with "V" blocks as shown, with the two end journals resting on the blocks. Position the dial gauge, as shown, and rotate the crankshaft slowly to read the runout.

Correct or replace the crankshaft if the runout is greater than the limit.

 09900-20606: Dial gauge (1/100 mm)  
 09900-20701: Magnetic stand  
 09900-21304: V-block (100 mm)

**Service Limit: 0.05 mm (0.002 in)**

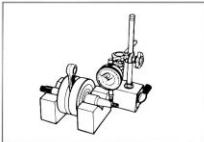

## BALANCERSHAFT AND GEAR

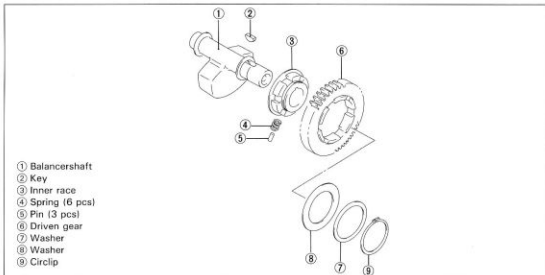

## DISASSEMBLY

- Remove the circlip ① and washers (②, ③).
- Remove the balancer driven gear.

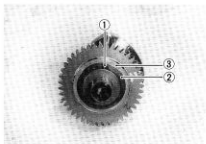

- Remove the 6 springs and 3 pins.

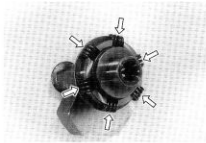

Inspect the crank balancershaft wear or damage.



**REASSEMBLY**

- When installing the inner race, align the pin with groove of inner race.
- When installing the balancer driven gear, align the two punched marks as shown in photo.
- When installing the 6 springs ① and 3 pins ②, set the pins ② to the triangle position as shown in photo.

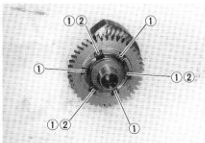
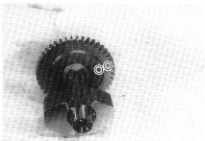
**CLUTCH DRIVE PLATE**

Measure the thickness of each drive plate with vernier calipers. Replace drive plates found to have worn down to the limit.

 09900-20102: Vernier calipers

**Standard**

Thickness No.1 & No.2: 2.9–3.1 mm (0.11–0.12 in)

**Service Limit**

Thickness No.1 & No.2: 2.6 mm (0.10 in)

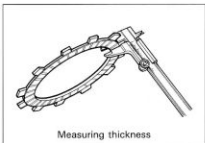

### CLUTCH DRIVEN PLATE

Measure each driven plate for distortion with a thickness gauge. Replace driven plates which exceed the limit.

 09900-20803: Thickness gauge

Service Limit: 0.1 mm (0.004 in)

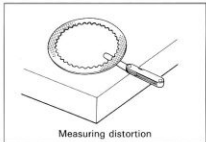

### CLUTCH SPRING FREE LENGTH

Measure the free length of each coil spring with a vernier calipers, and determine the elastic strength of each. Replace any spring not within the limit.

 09900-20102: Vernier calipers

Service Limit: 33.0 mm (1.30 in)

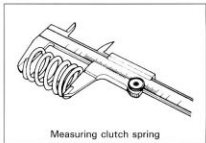

### CLUTCH RELEASE BEARING

Inspect the release bearing for any abnormality, particularly cracks, to decide whether it can be reused or should be replaced. Smooth engagement and disengagement of the clutch depends much on the condition of this bearing.

### CLUTCH RELEASE PINION AND RACK

Rotate the clutch release pinion by hand to inspect for a smooth rotation. If a large resistance is felt to rotation, inspect the pinion and rack for damage or wear. If the defect is found, replace them as a set.

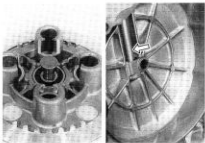



## STARTER CLUTCH

- ① Starter clutch
- ② Bearing
- ③ Starter idle gear
- ④ Idle gear shaft
- ⑤ Starter torque limiter

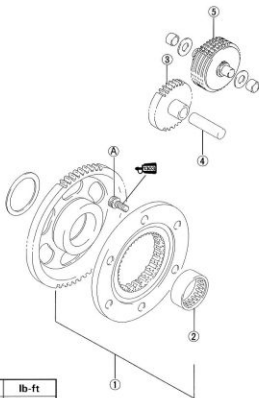

ITEM	N·m	kg·m	lb·ft
(A)	25	2.5	18.0

## DISASSEMBLY

- Remove the starter clutch gear.
  
- Remove the 3 bolts with a 6 mm hexagon wrench and 36 mm offset wrench.

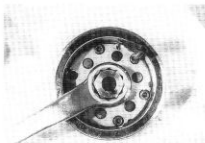

**STARTER CLUTCH**



Inspect the stater clutch wear or damage.

**REASSEMBLY**

- Apply **THREAD LOCK SUPER "1303"** to the bolts and tighten them to the specified torque.

 **99000-32030: THREAD LOCK SUPER "1303"**

 **Bolt: 25 N·m (2.5 kg·m, 18.0 lb·ft)**

Check that the rotor  turns in the direction of the arrow mark  on the rotor while holding the starter gear, and that the rotor never turns in the opposite direction of the arrow mark.

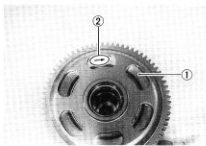
**STARTER TORQUE LIMITER****CAUTION**

Do not attempt to disassemble the starter torque limiter.  
It is not serviceable.

Check the slip torque with the special tools.

**Slip torque: 42–64 N·m (4.2–6.4 kg·m, 30.5–46.5 lb·ft)**

 **09930-73110: Starter torque limiter holder**

**09930-73120: Starter torque limiter socket**

Set the starter torque limiter to the special tools and vise as shown in the photograph.

If the slip torque is not within the specification, replace the starter torque limiter with a new one.

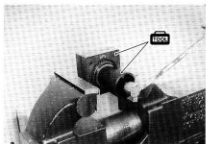

## TRANSMISSION

- Disassemble the transmission gears as shown in the illustration.

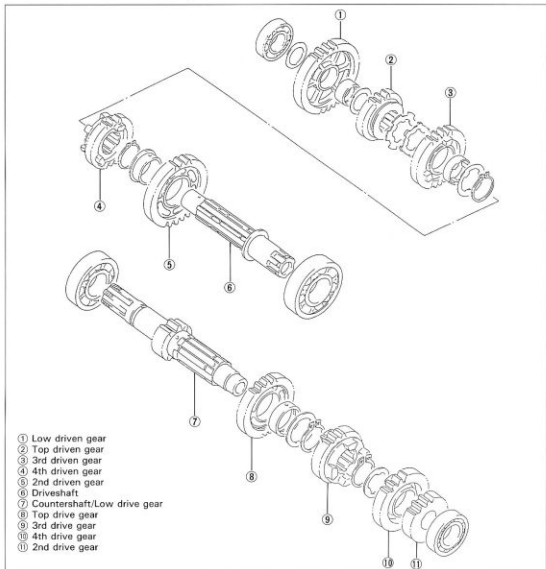

### 2ND DRIVE GEAR DISASSEMBLY

- Remove the 2nd drive gear by using the gear puller and appropriate attachment.

 09913-60910: Gear puller

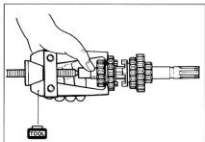

**SHIFT FORK – GROOVE CLEARANCE**

Using a thickness gauge, check the shifting fork clearance in the groove of its gear.

The clearance for each of the three shifting forks plays an important role in the smoothness and positiveness of shifting action.

**Shift fork-Groove clearance**

**Standard:** 0.10–0.30 mm (0.004–0.012 in)

**Service Limit:** 0.50 mm (0.020 in)

If the clearance checked is noted to exceed the limit specified, replace the fork or its gear, or both.

 **09900-20803: Thickness gauge**  
**09900-20102: Vernier calipers**

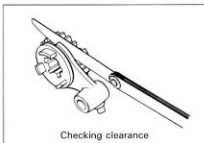
**Shift fork groove width**

**Standard:** 5.0–5.1 mm (0.197–0.200 in)

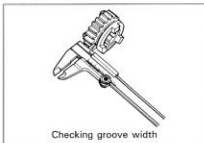
**Shift fork thickness**

**Standard:** 4.8–4.9 mm (0.189–0.193 in)

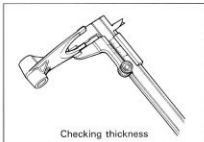

**REASSEMBLY**

Assemble the countershaft and driveshaft, in the reverse order of disassembly. Pay attention to following points:

**NOTE:**

Before installing the gears, lightly coat moly paste or engine oil to the driveshaft and countershaft.

 **99000-25140: SUZUKI MOLY PASTE**

- When installing a new circlip, pay attention to the direction of the circlip. Fit it to the side where the thrust is as shown in the illustration.

**CAUTION**

- Never reuse a circlip. After a circlip has been removed from a shaft, it should be discarded, and a new circlip must be installed.
- When installing a new circlip, care must be taken not to expand the end gap larger than required to slip the circlip over the shaft.
- After installing a circlip, always insure that it is completely seated in its groove and securely fitted.

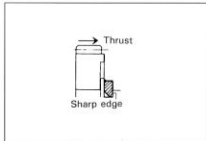
**2ND DRIVE GEAR**

- Press-fit 2nd drive gear ① onto the countershaft.

**NOTE:**

Before reassembling, coat the internal face of the 2nd drive gear with **THREAD LOCK SUPER "1303"**.

 **99000-32030: THREAD LOCK SUPER "1303"**
**NOTE:**

Take care not to smear 4th drive gear with **THREAD LOCK SUPER "1303"**.

**NOTE:**

- After mounting the 2nd drive gear, check that 4th drive gear spins smoothly by moving it with your fingers.
- This procedure may be performed only twice before shaft replacement is required.

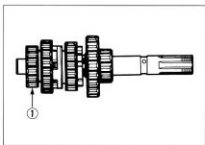
**3RD DRIVEN GEAR BUSHING**

- When installing the gear bushing onto the driveshaft, align the oil hole ② of the shaft with the bushing oil hole ③.

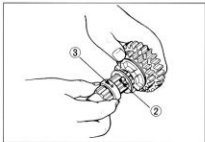

**NOTE:**

*In reassembling the transmission, attention must be given to the locations and positions of washers and circlips. The cross sectional view given here will serve as a reference for correctly mounting the gears, washers and circlips.*

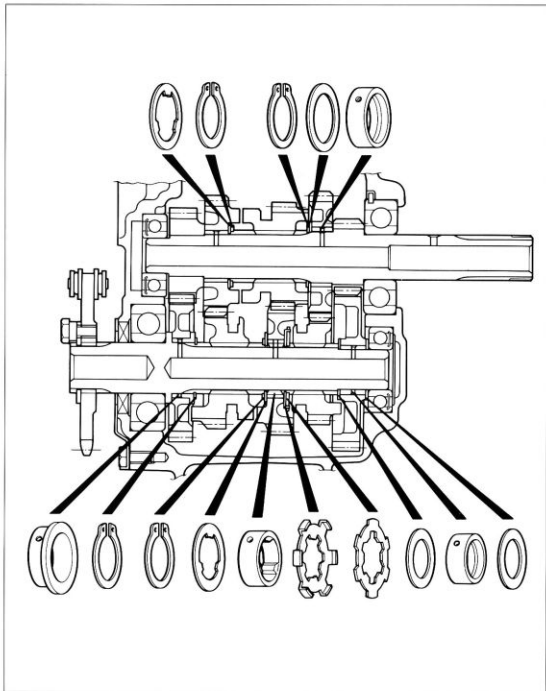

## OIL NOZZLE AND OIL JET

### REMOVAL

- Remove the oil nozzle ① and oil jet ② of the right crankcase.

### CAUTION

The removed oil jet ② should be replaced with a new one.



### INSPECTION

Check the oil nozzle for any damage or clogging.

### REASSEMBLY

- Install the new oil jet ② as shown in the illustration.

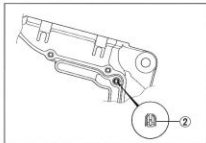

- Install the oil nozzle ①.
- Apply THREAD LOCK SUPER "1303" to the bolt and tighten to the specified torque.

 99000-32030: THREAD LOCK SUPER "1303"

 Bolt: 10 N·m (1.0 kg·m, 7.0 lb·ft)

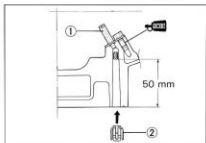

## CRANKCASE BEARINGS

Inspect the play of the crankcase bearings by hand while they are in the left and right crankcase. Rotate each crankcase bearing inner race by hand to inspect for abnormal noise and smooth rotation. Replace the bearing if there is anything unusual.

### NOTE:

When reassembling the bearing retainer ④, apply a small quantity of THREAD LOCK "1342" to the bearing retainer screws and bolts.

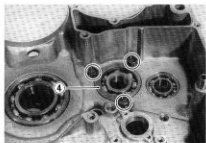
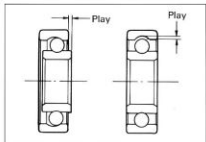

**OIL FILTER**

- Remove the oil filter cap.
- Remove the oil filter ①.
- Install the new oil filter.

**NOTE:**

Before installing the oil filter and oil filter cap, check to be sure that the spring ② and new O-rings ③ and ④ are installed correctly.

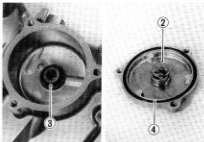
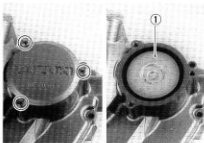
**GENERATOR**

- Remove the generator coil.

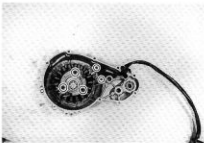

- Remove the bearing by removing the circlip.

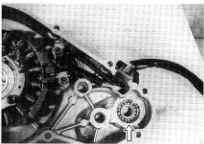



## ENGINE REASSEMBLY

The engine is reassembled by carrying out the steps of disassembly in the reverse order, but there are a number of steps that demand special descriptions or precautionary measures.

**NOTE:**

*Apply engine oil to each running and sliding part before reassembling.*

### OIL SEALS

- Fit the respective oil seals to the crankcase, clutch cover and gearshift cover.
- Apply SUZUKI SUPER GREASE "A" to the lip of oil seals.

 99000-32030: SUZUKI SUPER GREASE "A"

**CAUTION**

Replace the oil seals with new ones every disassembly to prevent oil leakage.

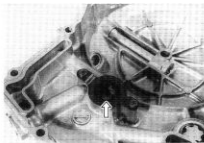
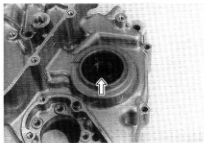

## CRANKSHAFT

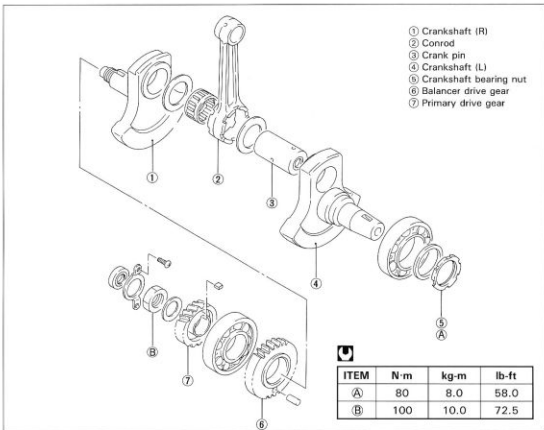

- Decide the width between the webs referring to the figure below when rebuilding the crankshaft.

STD width between webs:  $71.0 \pm 0.1$  mm  
 ( $2.795 \pm 0.004$  in)

- When mounting the crankshaft in the crankcase, it is necessary to pull its right end into the crankcase.

 09910-32812: Crankshaft installer  
 09910-32830: Attachment  
 09910-32860: Attachment

**CAUTION**

Never fit the crankshaft into the crankcase by striking it with a plastic hammer.  
 Always use the special tool, otherwise crankshaft alignment accuracy will be affected.

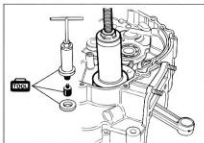
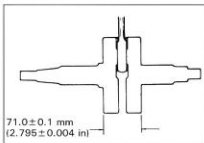

## BALANCERSHAFT

- When installing the balancershaft, align the punched marks (1, 2) on the balancer drive gear and driven gear.

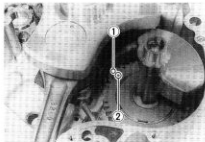

## GEARSHIFT MECHANISM

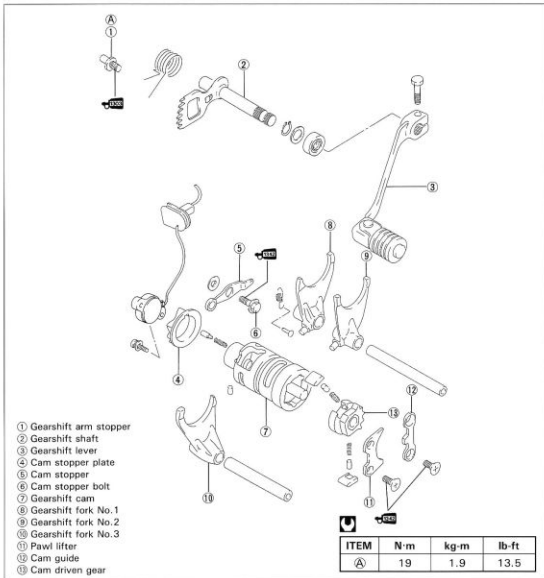

- After installing the countershaft assembly and driveshaft assembly into the right crankcase, fit the gearshift forks ①, ② and ③ into the gearshift fork grooves.

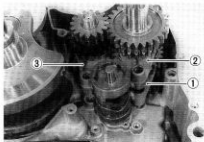

- ① For Top driven gear (No.1)
- ② For 4th driven gear (No.2)
- ③ For 3rd drive gear (No.3)

**NOTE:**

Three kinds of gearshift forks, ①, ② and ③ are used. They resemble each other very closely in external appearance and configuration.

Carefully examine the illustration for correct installing positions and directions.

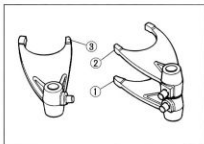

- Position the gearshift cam as shown in photo so that the gearshift fork shafts can be installed easily.



**NOTE:**

When replacing the gearshift cam stopper bolt ④, apply a small quantity of THREAD LOCK "1342" to the threaded part of the bolt.

 99000-32050: THREAD LOCK "1342"

- Hook the gearshift cam stopper spring.



## CRANKCASE

When reassembling the crankcase pay attention to the following points:

- Remove sealant material on the mating surfaces of right and left halves of crankcase and thoroughly remove oil stains.
- Apply SUZUKI BOND NO. 1207B uniformly to the mating surface of the left half of the crankcase, and assemble the cases within few minutes.

### 99104-31140: SUZUKI BOND NO. 1207B

- Fit the dowel pins ① on the right half as shown in photo.
- Apply engine oil to conrod big end of the crankshaft and all parts of the transmission gears.

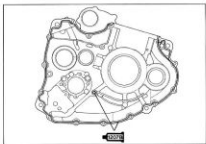

- After the crankcase bolts have been tightened, check if driveshaft and countershaft rotate smoothly.

### Crankcase bolt: 11 N·m (1.1 kg-m, 8.0 lb-ft)

- If a large resistance is felt to rotation, try to free the shafts by tapping the driveshaft or countershaft with a plastic hammer.

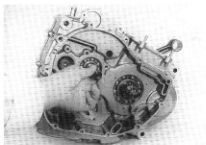

## CAM DRIVEN GEAR

- Install the gearshift pawls into the cam driven gear. The large shoulder (A) must face to the outside as shown in the illustration.
- When installing the cam guide ② and pawl lifter ③, apply a small quantity of THREAD LOCK "1342" to the securing screws ④.

### 99000-32050: THREAD LOCK "1342"

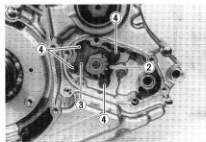
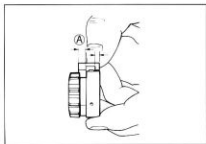

## GEARSHIFT SHAFT

- Fit a spring to the gearshift shaft correctly.
- Install the gearshift shaft. Match the center teeth of the gear on the gearshift shaft with the center teeth on the cam driven gear as shown.

### NOTE:

When replacing the gearshift arm stopper ①, apply a small quantity of **THREAD LOCK SUPER "1303"** to its threaded part and tighten it to the specified torque. (See page 7-24.)

### 99000-32030: **THREAD LOCK SUPER "1303"**

- Fit the dowel pins ② and new gasket.
- Fit the gearshift cover and tighten the bolts diagonally.

### NOTE:

After the gearshift cover and gearshift lever have been fitted, confirm that gear change is normal while turning the countershaft and driveshaft. If gear change is not obtained, it means that assembly of gears or installation of gearshift fork is incorrect. If this is the case, disassemble and trace the mistake.

## NEUTRAL POSITION INDICATOR SWITCH

- Install the neutral position indicator switch spring ③ and switch contact ④.

- Install the neutral position indicator switch with two screws.
- Install the breather cover.

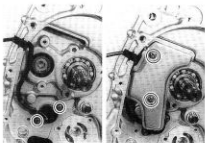
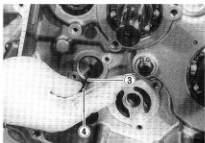
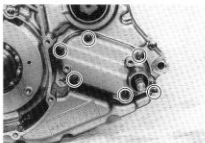
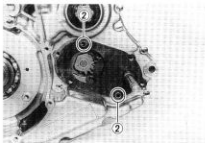
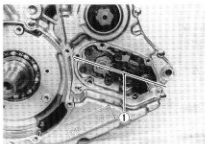

## OIL PUMP

- Before mounting oil pump, apply engine oil to the sliding surfaces of the case, outer rotor, inner rotor and shaft.
- Apply a small quantity of THREAD LOCK "1342" to the oil pump mounting screws.

 99000-32050: THREAD LOCK "1342"

- Tighten the oil pump mounting screws.
- Fix the oil pump driven gear with the circlip.

### NOTE:

After installing the oil pump driven gear, rotate the pump gear by hand to see if it turns smoothly.

- Fix the idle gear with the circlip.

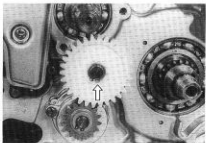
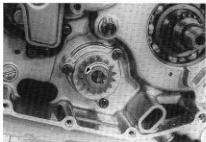
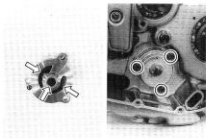

## CAM DRIVE CHAIN AND PRIMARY DRIVE GEAR

- Engage the cam drive chain.
- Fit the key ① in the key slot on the crankshaft, then install the primary drive gear and nut.

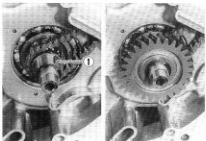

- Tighten the primary drive gear nut to the specified torque with the special tool.

 09910-20116: Conrod holder

 Primary drive gear nut: 100 N·m (10.0 kg·m, 72.5 lb·ft)

### NOTE:

This nut has left-hand thread nut.

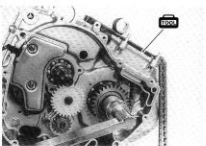

## CLUTCH

- ① Clutch release arm
- ② Clutch release pinion
- ③ Clutch release rack
- ④ Clutch pressure plate
- ⑤ Clutch sleeve hub
- ⑥ Washer seat
- ⑦ Concaved washer
- ⑧ Clutch driven plate
- No. 2 (Thicker plate, 1 pc)
- ⑨ Stopper ring
- ⑩ Clutch drive plate No. 2 (1 pc)
- ⑪ Clutch driven plate No. 1 (7 pcs)
- ⑫ Clutch drive plate No. 1 (7 pcs)
- ⑬ Primary driven gear ass'y

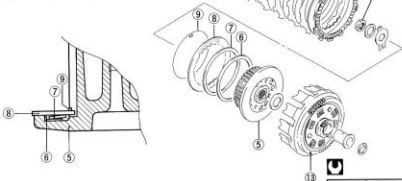
**NOTE:**

Check to be sure that concaved washer ⑦ is properly installed.

ITEM	N·m	kg·m	lb·ft
(A)	10	1.0	7.0
(B)	50	5.0	36.0

- Install the thrust washer ①.
- Install the spacer with primary driven gear assembly.

**NOTE:**

When inserting the spacer into the primary driven gear, apply engine oil to both inside and outside of the spacer.

- Install the thrust washer ②.

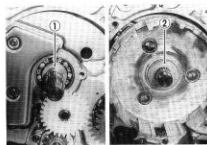

- Install the clutch sleeve hub and lock washer ③.

**NOTE:**

When installing the lock washer ③, align the slit ④ of lock washer with the rib of clutch sleeve hub.

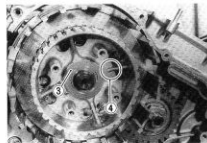



- Tighten the clutch sleeve hub nut to the specified torque with the special tool.

 09920-53740: Clutch sleeve hub holder

 Clutch sleeve hub nut: 50 N·m (5.0 kg·m, 36.0 lb-ft)

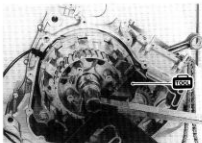

- After tightening the clutch sleeve hub nut, be sure to lock the nut by firmly bending the tongue of the lock washer.
- Install the clutch drive plates and driven plates one by one.
- Install the clutch pressure plate.



- Tighten the clutch spring mounting bolts diagonally to the specified torque with the special tool.

 09910-20116: Conrod holder

 Clutch spring mounting bolt: 10 N·m (1.0 kg·m, 7.0 lb-ft)

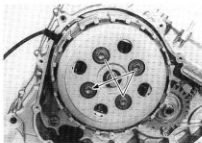

- Fit the dowel pins.

**CAUTION**

Use a new gasket to prevent oil leakage.

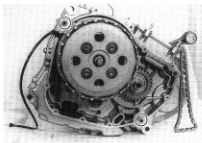

- Engage the teeth of clutch release rack with those of pinion gear at the clutch cover side, and replace clutch cover. Make sure that the rack and pinion gear engage positively. To install the cover, tap lightly with plastic hammer, and tighten the bolts.

①: Gasket

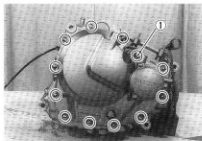

## STARTER CLUTCH AND GENERATOR

- Install the crankcase oil separator and spacer ①.

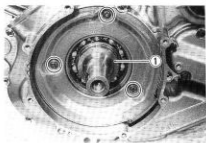

- Tighten the ring nut to the specified torque with the special tools.

 09917-23711: Ring nut socket wrench  
09910-20116: Conrod holder

 Ring nut: 80 N·m (8.0 kg-m, 58.0 lb-ft)

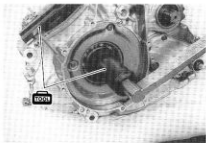

- Install the starter gear and thrust washer.
- Degrease the tapered portion of the generator rotor and also the crankshaft.

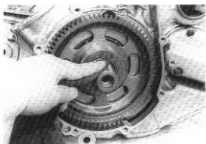

- Fill the key ② in the key slot on the crankshaft, then install the generator rotor.



- Apply a small quantity of THREAD LOCK SUPER "1303" to the threaded part of rotor bolt.

 99000-32030: THEAD LOCK SUPER "1303"



- Tighten the generator rotor bolt to the specified torque with the 36 mm off-set wrench.

 Generator rotor bolt: 160 N·m (16.0 kg·m, 115.5 lb-ft)

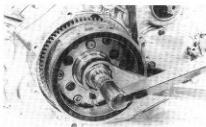

- Install the starter torque limiter and idle gear.
- Install the starter motor.

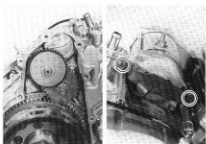

- Fit the dowel pin and install the new gasket.
- Install the generator cover.

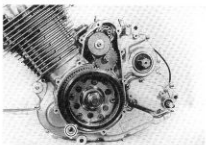

## OIL RING

Install the spacer ① into the oil ring groove first. Then install both side rails ②, one on each side of the spacer. The spacer and side rails do not have a specific top or bottom when they are new. When reassembling used parts, install them in their original place and direction.

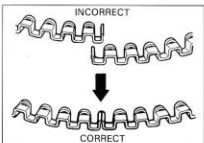
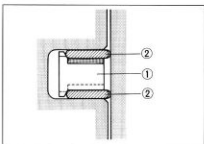

## TOP RING AND 2ND RING

Top and 2nd rings differ in the shape of the ring face. Top and 2nd rings have a letter "R" or "RN" marked on the side. Be sure to bring the marked side to top when fitting them to the piston.

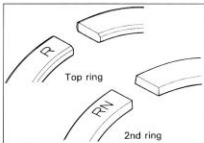

- Position the gaps of the three rings as shown. Before inserting piston into the cylinder, check that the gaps are so located.

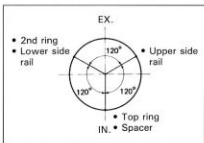

- Place a clean rag over the cylinder base to prevent the piston pin circlips from dropping into the crankcase.
- Rub a small quantity of SUZUKI MOLY PASTE onto the piston pin.

**999000-25140: SUZUKI MOLY PASTE**

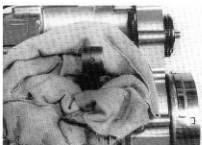

- When fitting the piston, turn arrow mark ① on the piston head to exhaust side.
- Fit the piston pin circlips with long-nose pliers.

### CAUTION

Use new piston pin circlip to prevent circlip failure which will occur with a bent one.

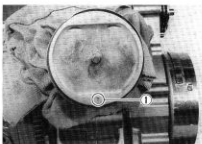

- Fit the dowel pins ② to the crankcase and attach a new gasket.

### CAUTION

Use a new gasket to prevent oil leakage.



- Hold each piston ring with proper position, and insert the piston into the cylinder.

**NOTE:**

When mounting the cylinder, keep the camshaft drive chain ① taut. The camshaft drive chain must not be caught between cam drive chain sprocket and crankcase when crankshaft is rotated.

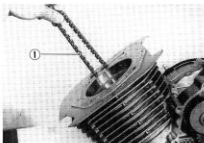

- Install the cam chain guide.

**NOTE:**

There is a holder for the bottom end of the cam chain guide cast in the crankcase. Be sure that the cam chain guide ② is inserted properly.

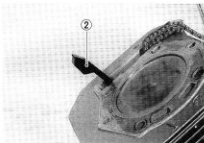

- Temporarily tighten the cylinder base nuts.

- Fit the dowel pins ③ to the cylinder and attach a new gasket.

**CAUTION**

Use a new cylinder head gasket to prevent oil leakage. Do not use the old gasket.



- Place the cylinder head on the cylinder.
- Cylinder head bolts and new gaskets must be fitted in the correct position, as shown in the photograph.

Ⓐ: 200 mm bolt

Ⓑ: 190 mm bolt

Ⓒ: 180 mm bolt

**NOTE:**

Apply engine oil to the new gaskets before installing.

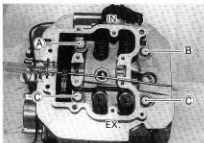

- Fasten the cylinder head by tightening the bolts and nuts diagonally. Tighten each bolt and nut to the specified torque.

- **Cylinder head bolt: 38 N·m (3.8 kg·m, 27.5 lb-ft)**  
**Cylinder head nut: 25 N·m (2.5 kg·m, 18.0 lb-ft)**

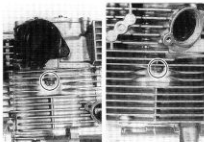

- After tightening the cylinder head bolts and nuts, tighten the cylinder base nut to the specified torque.

 Cylinder base nut: 10 N·m (1.0 kg·m, 7.0 lb-ft)

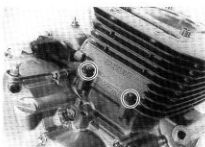

## CAMSHAFT

- Turn the crankshaft counterclockwise with the box wrench and align "T" line ① on the generator rotor with the center of hole on the generator cover keeping the camshaft drive chain pulled upward.

### CAUTION

If crankshaft is turned without drawing the camshaft drive chain upward, the chain will be caught between crankcase and cam chain drive sprocket.

- Install the C-ring ② into the ring groove of the cylinder head.

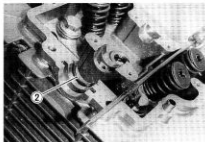
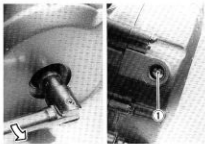

### NOTE:

Apply grease on the cam sprocket locating pin and install the pin into the camshaft.

- Engage the chain on the cam sprocket with the locating pin hole ③ at two o'clock position.

### NOTE:

Do not rotate the generator rotor while doing this. When the sprocket is not positioned correctly, turn the sprocket. When installing the camshaft into the cam sprocket, pay attention not to dislodge the locating pin or it may fall into the crankcase.

- Align the engraved line mark ④ on the camshaft so it is parallel with the surface of the cylinder head.

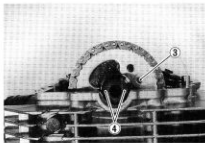

- Fit the lock washer so that it is covering the locating pin.
- Apply THREAD LOCK SUPER "1303" to the cam sprocket bolts and tighten them to the specified torque.

 Cam sprocket bolt: 15 N·m (1.5 kg·m, 11.0 lb-ft)

 99000-32030: THREAD LOCK SUPER "1303"

- Bend up the washer tongue positively to lock the bolts.

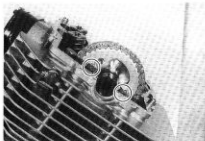

- Apply SUZUKI MOLY PASTE to the camshaft journals and cam faces.

 99000-25140: SUZUKI MOLY PASTE

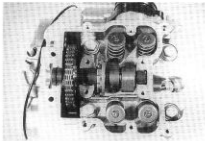

- Thoroughly wipe off oil from the fitting surfaces of cylinder head and cover.
- Fit the dowel pins ① and camshaft end cap ② to the cylinder head side.

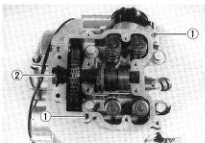

- Apply SUZUKI BOND NO. 1207B uniformly to the mating surface of the cylinder head cover, and install the cylinder head cover within few minutes.

 99104-31140: SUZUKI BOND NO. 1207B

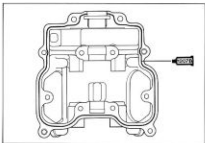

- Fit the two gaskets ③ to the head cover bolts correctly as shown in Fig.

#### CAUTION

Use a new gasket to prevent oil leakage.

#### NOTE:

When tightening the cylinder head cover bolts, the piston must be at top dead center on the compression stroke.



- Lightly tighten the cylinder head cover bolts sequentially in the ascending order of numbers, and then if everything is satisfactory, tighten securely with a torque wrench to the specified torque.

 **Cylinder head cover bolt:** 10 N·m (1.0 kg·m, 7.0 lb-ft)



- Turn the slotted end of the chain tensioner adjuster to lock it with a screwdriver in the clockwise direction.
- Install the chain tensioner adjuster on the cylinder.

 **Cam chain tensioner adjuster mounting bolt ①:**  
10 N·m (1.0 kg·m, 7.0 lb-ft)

- Turn back and pull out the screwdriver from the chain tensioner adjuster. As the cylinder turns, the tensioner rod is advanced under spring force and pushes the tensioner against the cam drive chain.

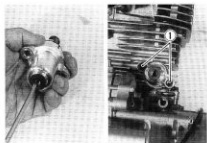

**NOTE:**

The cam drive chain tensioner adjuster is maintained at the proper tension by an automatically adjusted tensioner. Before installing the cam drive chain tensioner adjuster, inspect the smooth movement.

- Tighten the tensioner adjuster cap bolt ②.

 **Bolt ②:** 6 N·m (0.6 kg·m, 4.5 lb-ft)

- Install the oil pipe and tighten the union bolt to the specified torque.

 **Oil pipe union bolt ③:** 23 N·m (2.3 kg·m, 16.5 lb-ft)  
**④:** 20 N·m (2.0 kg·m, 14.5 lb-ft)

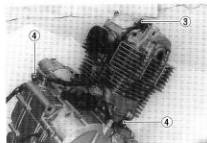
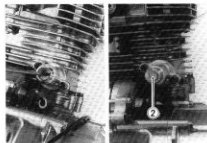



# FUEL AND LUBRICATION SYSTEM

## CONTENTS

<b>FUEL SYSTEM</b> .....	4- 1
<b>FUEL VALVE</b> .....	4- 2
<b>FUEL TANK</b> .....	4- 3
<b>CARBURETOR</b> .....	4- 4
<b>CONSTRUCTION</b> .....	4- 4
<b>SPECIFICATIONS</b> .....	4- 5
<b>I.D. NO. LOCATION</b> .....	4- 6
<b>SLOW SYSTEM</b> .....	4- 7
<b>MAIN SYSTEM</b> .....	4- 8
<b>STARTER SYSTEM</b> .....	4- 9
<b>FLOAT SYSTEM</b> .....	4- 9
<b>REMOVAL</b> .....	4-10
<b>DISASSEMBLY</b> .....	4-10
<b>CARBURETOR CLEANING</b> .....	4-11
<b>INSPECTION</b> .....	4-13
<b>NEEDLE VALVE INSPECTION</b> .....	4-13
<b>FLOAT HEIGHT ADJUSTMENT</b> .....	4-13
<b>THROTTLE POSITION SWITCH</b> .....	4-13
<b>REASSEMBLY AND REMOUNTING</b> .....	4-14
<b>LUBRICATION SYSTEM AND COOLING SYSTEM</b> .....	4-14
<b>ENGINE LUBRICATION/CYLINDER HEAD</b>	
<b>COOLING SYSTEM CHART</b> .....	4-15
<b>OIL COOLER</b> .....	4-17

## FUEL SYSTEM

When turning starter motor, negative pressure is generated in the combustion chamber. This negative pressure works on the diaphragm of fuel valve through passage way provided in the carburetor main bore and vacuum hose, and diaphragm builds up a negative pressure which is higher than the spring pressure. Valve in the fuel valve is forced to open due to diaphragm operation, and thus allows fuel to flow into carburetor float chamber.

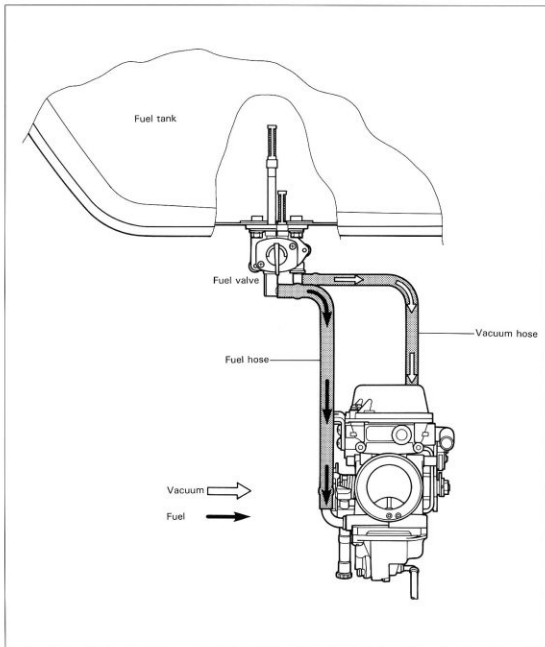

## FUEL VALVE

### FUEL VALVE MECHANISM

A valve is provided at the end of the fuel valve lever and can switch over to "ON", "PRI" and "RES".

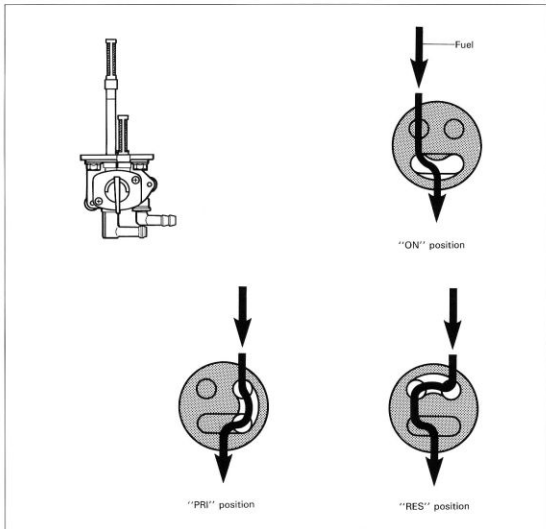

### FUEL VALVE/FUEL FILTER REMOVAL

- Remove the frame cover and seat. (Refer to pages 5-1 and 2.)
- Remove the fuel tank. (Refer to page 4-3.)
- Remove the fuel valve by removing the mounting bolts.

#### **▲ WARNING**

Gasoline is very explosive. Extreme care must be taken. Gaskets and O-ring must be replaced with new ones to prevent fuel leakage.

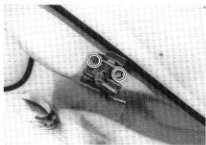

### INSPECTION AND CLEANING

If the fuel filter is dirty with sediment or rust, fuel will not flow smoothly and loss in engine power may result. Clean the fuel filter with compressed air.



### FUEL TANK

#### FUEL TANK REMOVAL

- Remove the frame cover and seat. (Refer to pages 5-1 and 2.)
- Turn the fuel valve to "ON" position.

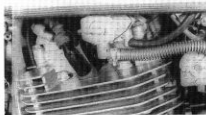

- Remove the fuel tank mounting bolts ①.
- Slide the fuel tank backward and lift up it after disconnecting the fuel hose ② and vacuum hose ③.
- Remove the fuel tank.

#### **⚠ WARNING**

Gasoline is very explosive. Extreme care must be taken.

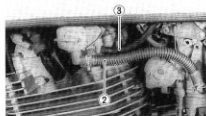
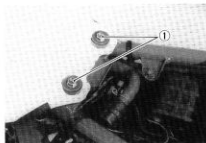

## CARBURETOR CONSTRUCTION

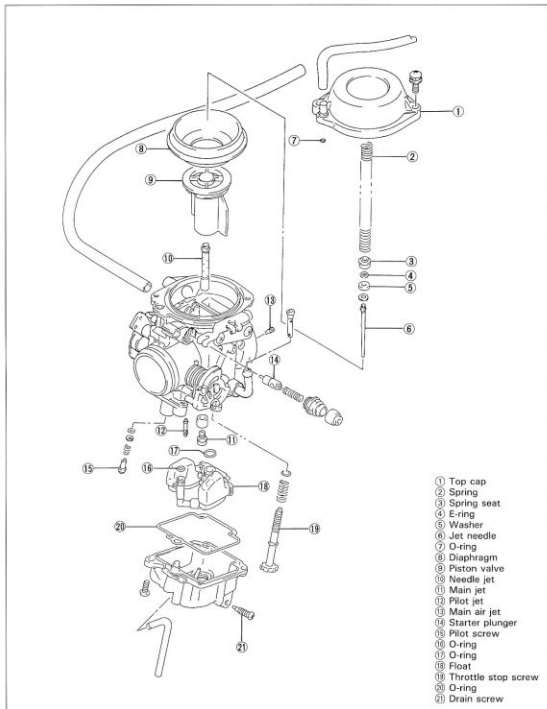

## SPECIFICATIONS

ITEM	SPECIFICATION			
	E-02,04,34	E-37	E-17,22,24	U-type E-22
Carburetor type	MIKUNI BST40SS	←	←	←
Bore size	40 mm	←	←	←
I.D. No.	32E0	32E8	32E3	32E4
Idle r/min.	1 500 ± 100 r/min	←	←	←
Float height	14.7 ± 1.0 mm (0.58 ± 0.04 in)	←	←	←
Main jet (M.J.)	# 140	←	←	←
Jet needle (J.N.)	6F19-3rd	←	←	←
Needle jet (N.J.)	Y-5	←	←	←
Throttle valve (Th.V.)	# 95	←	←	←
Pilot jet (P.J.)	# 42.5	←	←	←
Starter jet (G.S.)	# 40	←	←	←
Pilot screw (P.S.)	PRE-SET (1½ turns back)	←	PRE-SET (1.0 turn back)	PRE-SET (1½ turns back)
Throttle cable play (pulling cable)	0.5—1.0 mm (0.02—0.04 in)	←	←	←
Starter cable play	0.5—1.0 mm (0.02—0.04 in)	←	←	←

## COUNTRY OR AREA

E-02 : U.K.	E-24 : Australia
E-03 : U.S.A.	E-28 : Canada
E-04 : France	E-33 : California (U.S.A.)
E-17 : Sweden	E-34 : Italy
E-18 : Switzerland	E-37 : Brazil
E-22 : Germany	

ITEM	SPECIFICATION			
	E-03	E-33	E-28	E-18
Carburetor type	MIKUNI BST40SS	←	←	←
Bore size	40 mm	←	←	←
I.D. No.	32E1	32E6	32E5	32E2
Idle r/min.	1 500 ± 100 r/min	←	←	1 500 ± 50 r/min
Float height	14.7 ± 1.0 mm (0.58 ± 0.04 in)	←	←	←
Main jet (M.J.)	# 140	←	# 140	# 137.5
Jet needle (J.N.)	6F23	←	6F19-3rd	6H21-4th
Needle jet (N.J.)	Y-5M	←	Y-5	←
Throttle valve (Th.V.)	# 95	←	←	←
Pilot jet (P.J.)	# 42.5	←	# 42.5	←
Starter jet (G.S.)	# 40	←	←	←
Pilot screw (P.S.)	PRE-SET	←	PRE-SET (1½ turns back)	PRE-SET (1.0 turn back)
Throttle cable play (pulling cable)	0.5 – 1.0 mm (0.02 – 0.04 in)	←	←	←
Starter cable play	0.5 – 1.0 mm (0.02 – 0.04 in)	←	←	←

### I.D. NO. LOCATION

Each carburetor has I.D. Number ① printed on the carburetor body according to its specification.

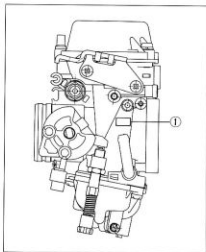

**SLOW SYSTEM**

This system supplies fuel during engine operation with throttle valve ① closed or slight opened. The fuel from float chamber ② is metered by pilot jet ③ where it mixes with air coming in through pilot air jet ④. This mixture, rich with fuel, then goes up through pilot passage to pilot screw ⑤. A part of the mixture is discharged into the main bore out of bypass ports ⑥. The remainder of mixture is metered by pilot screw ⑤ and sprayed out into the main bore through pilot outlet ⑦.

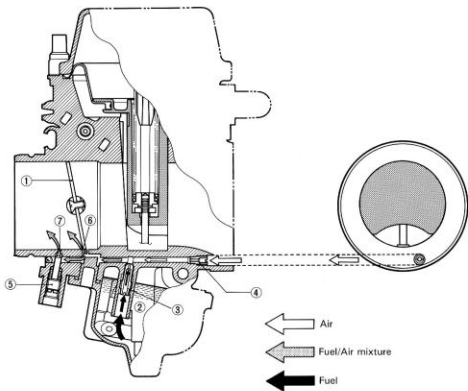



## MAIN SYSTEM

As throttle valve ① is opened, engine speed rises, and this increases negative pressure in the venturi (A). Consequently the piston valve ② moves upward.

Meanwhile, the fuel in float chamber ③ is metered by main jet ④, and the metered fuel enters needle jet ⑤, in which it mixes with the air admitted through main air jet ⑥ to form an emulsion.

The emulsified fuel then passes through the clearance between needle jet ⑤ and jet needle ⑦, and is discharged into the venturi (A), in which it meets main air stream being drawn by the engine.

Mixture proportioning is accomplished in needle jet ⑤; the clearance through which the emulsified fuel must flow in large or small, depending ultimately on throttle position.

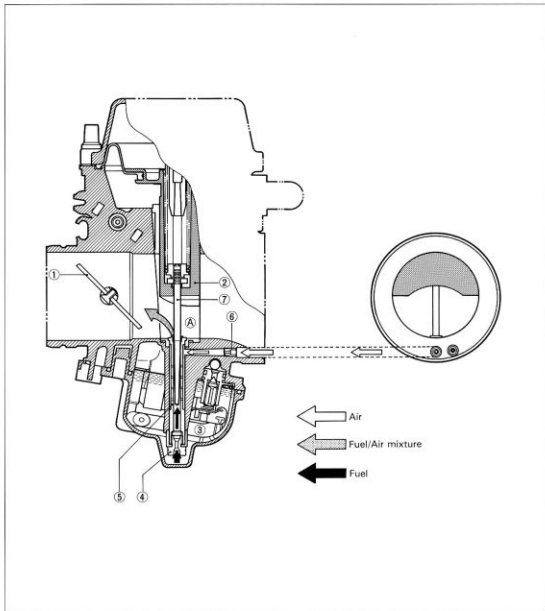

## STARTER SYSTEM

Pulling the starter cable ①, fuel is drawn into the starter circuit from the float chamber ②. Starter jets ③, ④ meters this fuel, which then flows into fuel pipe ⑤ and mixes with the air coming from the float chamber. The mixture, rich in fuel content, reaches starter plunger ⑥ and mixes again with the air coming through a passage extending from behind the diaphragm. The two successive mixings of fuel with air are such that proper fuel/air mixture for starting is produced when the mixture is sprayed out through starter outlet port ⑦ into the main bore.

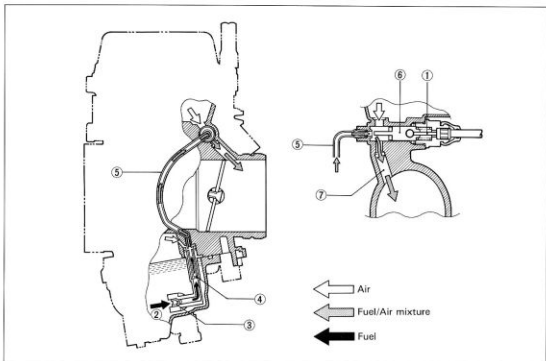

## FLOAT SYSTEM

Floats ① and needle valve ② are associated with the same mechanism, so that, as the floats ① move up and down, the needle valve ② too moves likewise.

When fuel level is up in float chamber ③, floats ① are up and needle valve ② remains pushed up against valve seat. Under this condition, no fuel enters the float chamber ③. As the fuel level falls, floats ① go down and needle valve ② unseats itself to admit fuel into the chamber ③. In this manner, needle valve ② admits and shuts off fuel alternately to maintain a practically constant fuel level inside the float chamber ③.

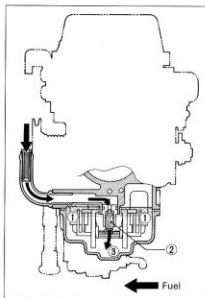

## REMOVAL

Refer to page 3-4.

## DISASSEMBLY

### NOTE:

Before disassembly, prepare a clean and well lit work place where carburetor components can be layed out neatly and won't get lost.

- Remove the carburetor top cap ①.

### CAUTION

Do not blow the carburetor body with compressed air, before removing the diaphragm. It may cause a damage to the diaphragm.

- Remove the piston valve return spring ② and piston valve with diaphragm ③.

- Remove the jet needle ④ out of the piston valve.

- Remove the float chamber body ⑤.

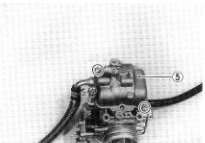
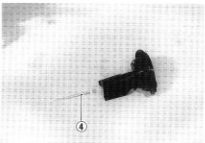
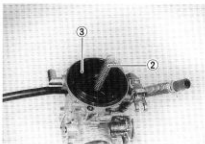
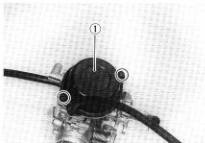

- Remove the float assembly ① and needle valve ②.

### ⚠ CAUTION

Do not use a wire for cleaning the valve seat.

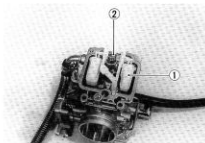

- Remove the main jet ③, pilot jet ④ and pilot screw ⑤ (Refer to PILOT SCREW REMOVAL of page 4-12 for E-03, 18 and 33 models).

### ⚠ CAUTION

Do not use a wire for cleaning of passage and jets.

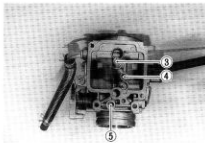

#### NOTE:

Before removing the pilot screw ⑤, slowly turn the pilot screw in clockwise and count the number of turns until the screw is lightly seated. Make a note of how many turns were made so the screw can be reset correctly after removing.

- Remove the main air jet ⑥.

### ⚠ CAUTION

Do not use a wire for cleaning of jet.

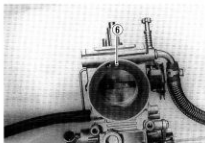

## CARBURETOR CLEANING

### ⚠ WARNING

Some carburetor cleaning chemicals, especially dip-type soaking solutions, are very corrosive and must be handled carefully. Always follow the chemical manufacturer's instructions on proper use, handling and storage.

#### NOTE:

Remove the pilot screw as described next page before cleaning.

- Clean all jets with a spray-type carburetor cleaner and blow dry with compressed air.
- Clean all circuits of the carburetor thoroughly - not just the perceived problem area. Clean the circuits in the carburetor body with a spray-type cleaner and allow each circuit to soak if necessary to loosen dirt and varnish. Blow the body dry with compressed air.

#### **CAUTION**

Do not use wire to clean jets or passageways. Wire can damage jets and passageways. If the components cannot be cleaned with a spray cleaner it may be necessary to use a dip-type cleaning solution and allow them to soak. Always follow the chemical manufacturer's instructions for proper use and cleaning of the carburetor components.

- After cleaning, reassemble the carburetor with new seals and gaskets. Reinstall the pilot screw to the original factory setting with a new O-ring seal.
- Install a new cap over the pilot screw opening. (for E-03, 18, 33 models)

#### **PILOT SCREW REMOVAL (FOR E-03, 18 AND 33 MODELS)**

Because harsh cleaning solvents can damage the O-ring seals in the pilot system, the pilot system components should be removed before cleaning.

- Use a 1/8" size drill bit with a drill-stop to remove the pilot screw plug. Set the drill-stop 6 mm from the end of the bit to prevent drilling into the pilot screw. Carefully drill through the plug.
- Thread a self-tapping sheet metal screw into the plug. Pull on the screw head with pliers to remove the plug. Carefully clean any metal shavings from the area.
- Slowly turn the pilot screw in clockwise and count the number of turns until the screw is lightly seated. Make a note of how many turns were made so the screw can be reset correctly after cleaning.
- Remove the pilot screw with the spring, washer, and O-ring.
- After cleaning reinstall the pilot screw to the original setting by turning the screw in until it lightly seats, and then backing it out the same number of turns counted during disassembly.
- Install new plug by tapping it into place with a punch.

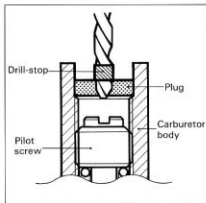

## INSPECTION

Check the following items for any damage.

- \* Pilot jet
- \* Main jet
- \* Main air jet
- \* Pilot air jet
- \* Needle jet air bleeding hole
- \* Float
- \* Needle valve
- \* Starter jet
- \* Gasket and O-ring
- \* Throttle shaft oil seal
- \* Diaphragm
- \* Pilot outlet and by-pass holes

## NEEDLE VALVE INSPECTION

If foreign matter is caught between the valve seat and the needle, the gasoline will continue flowing and cause it to overflow. If the seat and needle are worn beyond the permissible limits, similar trouble will occur. Conversely, if the needle sticks, the gasoline will not flow into the float chamber. Clean the float chamber and float parts with gasoline. If the needle is worn as shown in the illustration, replace it together with a valve seat. Clean the fuel passage of the mixing chamber with compressed air.

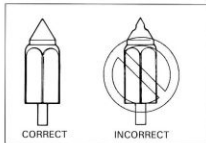

## FLOAT HEIGHT ADJUSTMENT

To check the float height, invert the carburetor body, with the float arm kept free, measure the height (A) while float arm is just in contact with needle valve by using calipers. Bend the tongue as necessary to bring the height (A) to this value.

Float height (A):  $14.7 \pm 1.0$  mm ( $0.58 \pm 0.04$  in)

 09900-20102: Vernier calipers

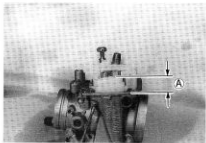

## THROTTLE POSITION SWITCH (Except for E-03,18,24,28 and 33 models)

- Remove the fuel tank. (Refer to page 4-3.)

Inspect the throttle position switch for continuity with pocket tester. If any abnormality is found, replace the respective switch assemblies with new ones.

 09900-25002: Pocket tester

 Tester knob indication: X 1Ω range

Position	Color	
	B	B
ON (full-throttle)	○ ————— ○	○ ————— ○
OFF		

B: Black

### NOTE:

When making above test, it is not necessary to start the engine.

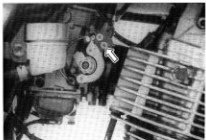

## REASSEMBLY AND REMOUNTING

Reassemble and remount the carburetor assembly in the reverse order of removal and disassembly.

- When installing the carburetor top cap, align the vacuum ports (①, ②).
  
- After remounting the carburetor, the following adjustments are necessary.
  - \* Engine idle r/min ..... Page 2-6
  - \* Throttle cable play ..... Page 2-6



## LUBRICATION SYSTEM AND COOLING SYSTEM

### OIL PRESSURE

Refer to page 2-18.

### OIL FILTER

Refer to page 2-8.

### OIL SUMP FILTER

Refer to page 3-16.

#### NOTE:

*When separating the crankcase, wash the oil sump filter with cleaning solvent, and then blow compressed air through it to dry off solvent.*

ENGINE LUBRICATION/CYLINDER HEAD COOLING SYSTEM CHART

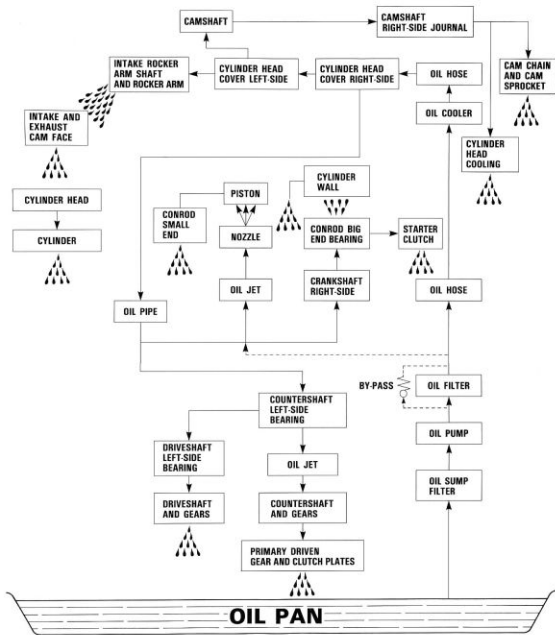



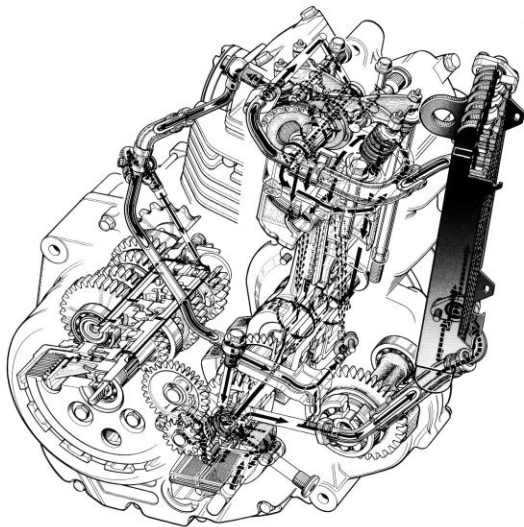

## OIL COOLER

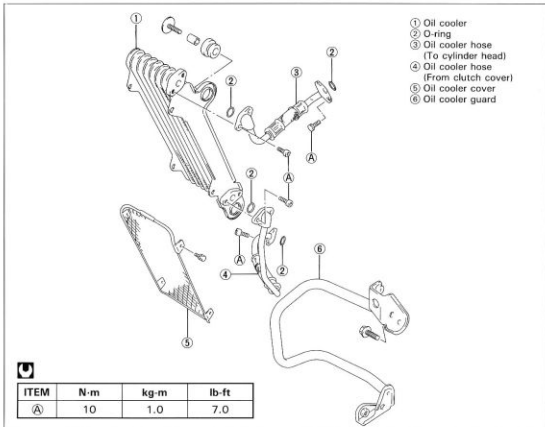

## REMOVAL

- Drain engine oil. (Refer to page 3-1.)
  - Remove the oil cooler hose mounting bolts.
- 
- Remove the oil cooler holder with cooler by removing its mounting bolts.

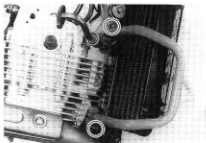
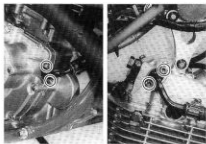

# CHASSIS

## CONTENTS

FRAME COVER AND SEAT .....	5- 1
FRONT WHEEL .....	5- 2
REMOVAL .....	5- 2
INSPECTION AND DISASSEMBLY .....	5- 3
REASSEMBLY AND REMOUNTING .....	5- 4
FRONT BRAKE .....	5- 6
BRAKE PAD REPLACEMENT .....	5- 7
BRAKE FLUID REPLACEMENT .....	5- 7
CALIPER REMOVAL AND DISASSEMBLY .....	5- 8
CALIPER INSPECTION .....	5- 9
CALIPER REASSEMBLY AND REMOUNTING .....	5- 9
BRAKE DISC INSPECTION .....	5-10
MASTER CYLINDER REMOVAL AND DISASSEMBLY .....	5-11
MASTER CYLINDER INSPECTION .....	5-12
MASTER CYLINDER REASSEMBLY AND REMOUNTING .....	5-13
FRONT FORK .....	5-14
REMOVAL AND DISASSEMBLY .....	5-14
INSPECTION .....	5-16
REASSEMBLY AND REMOUNTING .....	5-17
STEERING .....	5-20
REMOVAL AND DISASSEMBLY .....	5-20
INSPECTION .....	5-25
REASSEMBLY AND REMOUNTING .....	5-25
REAR WHEEL .....	5-27
REMOVAL .....	5-27
INSPECTION AND DISASSEMBLY .....	5-29
REASSEMBLY AND REMOUNTING .....	5-31
REAR BRAKE .....	5-33
BRAKE PAD REPLACEMENT .....	5-34
BRAKE FLUID REPLACEMENT .....	5-34
CALIPER REMOVAL AND DISASSEMBLY .....	5-35
CALIPER AND DISC INSPECTION .....	5-36
CALIPER REASSEMBLY AND REMOUNTING .....	5-36
MASTER CYLINDER REMOVAL AND DISASSEMBLY .....	5-37
MASTER CYLINDER INSPECTION .....	5-38
MASTER CYLINDER REASSEMBLY AND REMOUNTING .....	5-38
REAR SWINGARM AND SUSPENSION .....	5-39
REMOVAL .....	5-40
INSPECTION AND DISASSEMBLY .....	5-42
REASSEMBLY AND REMOUNTING .....	5-44
REASSEMBLING INFORMATION .....	5-45
FINAL INSPECTION AND ADJUSTMENT .....	5-46
LOWERING THE SEAT HEIGHT .....	5-47
OPTIONAL PARTS SUPPLY .....	5-47
SPECIAL TOOLS .....	5-47
FRONT FORK .....	5-48
REAR SHOCK ABSORBER .....	5-53
SIDE STAND .....	5-56
WARNING LABEL .....	5-57

## FRAME COVER AND SEAT REMOVAL AND REMOUNTING

- Remove the right and left frame covers by removing the mounting screws.

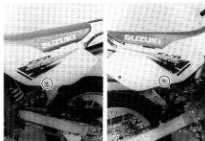

- Remove the seat by removing the mounting bolts.

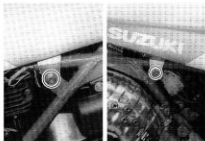

- Remount the seat and frame covers.

## FRONT WHEEL

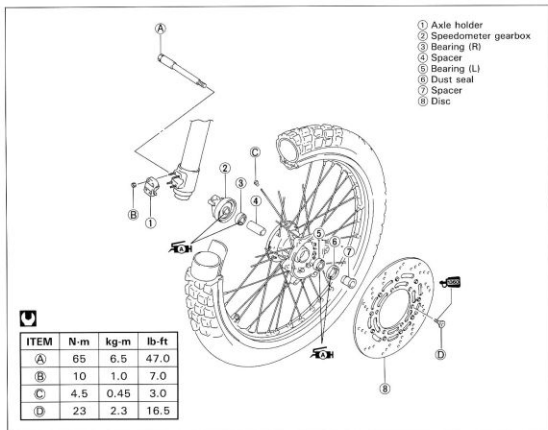

## REMOVAL

- Loosen the front axle holder nuts ① and axle shaft ②.
- Carefully position a jack under the chassis tubes and raise until the front wheel is slightly off the ground.
- Remove the front wheel by removing the front axle.

## NOTE:

Do not operate the brake lever while dismantling the front wheel.

- Remove the disc by removing the mounting bolts.

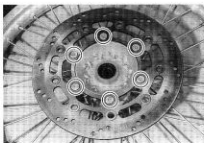
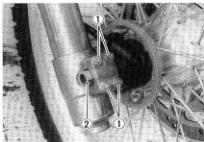

## INSPECTION AND DISASSEMBLY

## WHEEL BEARING

Inspect the play of bearing inner ring by hand while mounted in the wheel.

Rotate the inner ring by hand to inspect if any abnormal noise occurs or rotating smoothly.

Replace the bearing if there is anything unusual.

- Remove the dust seal.
- Drive out the both bearing with the special tool in the following procedures.

 **09941-50111: Bearing remover**

- Insert the adapter into the bearing.
- After inserting the wedge bar from the opposite side, lock the wedge bar in the slit of the adapter.
- Drive out the bearing by knocking the wedge bar.

 **CAUTION**

The removed bearing should be replaced with new ones.

## FRONT AXLE

Check the front axle runout with a dial gauge and replace it if the runout exceeds the limit.

 **09900-20606: Dial gauge (1/100 mm)**

**09900-20701: Magnetic stand**

**09900-21304: "V" block set**

**Service Limit: 0.25 mm (0.010 in)**

## WHEEL RIM

Make sure that the wheel rim runout does not exceed the service limit when checked as shown.

An excessive runout is usually due to worn or loose wheel bearings and can be reduced by replacing the bearings. If bearing replacement fails to reduce the runout, replace the wheel.

**Service Limit : 2.0 mm (0.08 in)**  
(Axial and Radial)

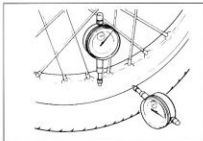
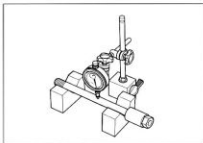
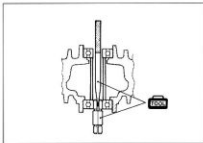
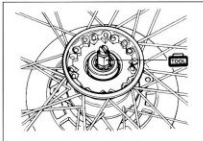
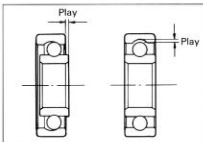

**SPOKE NIPPLE**

Check to be sure that all nipples are tight, and retighten them as necessary.

 Spoke nipple: 4.5 N·m (0.45 kg·m, 3.0 lb-ft)

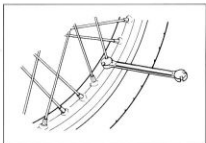

**TIRE** (Refer to page 2-12.)

**REASSEMBLY AND REMOUNTING**

Reassemble and remount the front wheel in the reverse order of removal and disassembly, and also carry out the following steps:

**WHEEL BEARING**

- Apply grease to the bearings.

 99000-25030: SUZUKI SUPER GREASE "A"



- Install the wheel bearings with the special tools.

 09924-84510: Bearing installer  
09924-84521: Bearing installer

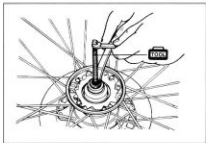
**NOTE:**

First install the wheel bearing for left side.

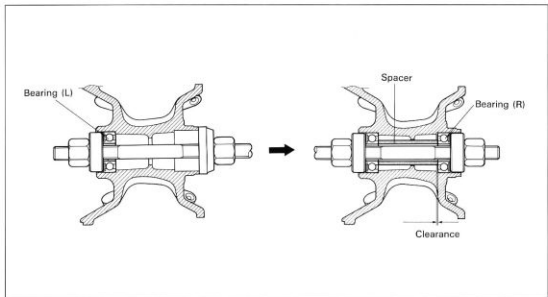

## BRAKE DISC



- Make sure that the brake disc is clean and free of any greasy matter. Apply THREAD LOCK SUPER "1360" to the disc mounting bolts and tighten them to the specified torque.

 99000-32130: THREAD LOCK SUPER "1360"

 Disc bolt: 23 N·m (2.3 kg·m, 16.5 lb·ft)

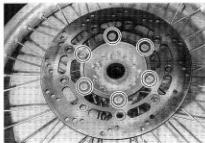
- Align the drive lugs  to the recesses  of the wheel hub.



- Before tightening the front axle, position the stopper  of speedometer gearbox against stopper .

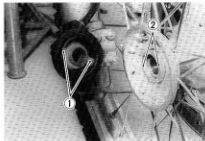

- Tighten the front axle to the specified torque and then move the front fork up and down.
- Tighten the axle holder nuts to the specified torque.

## NOTE:

When tightening the axle holder nuts, first tighten the upper nuts.

 Front axle: 65 N·m (6.5 kg·m, 47.0 lb·ft)  
Axle holder nut: 10 N·m (1.0 kg·m, 7.0 lb·ft)

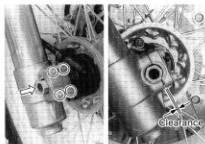
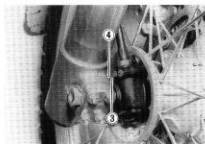



## FRONT BRAKE

- ① Piston/cup set  
 ② Brake hose  
 ③ Pad  
 ④ Piston set

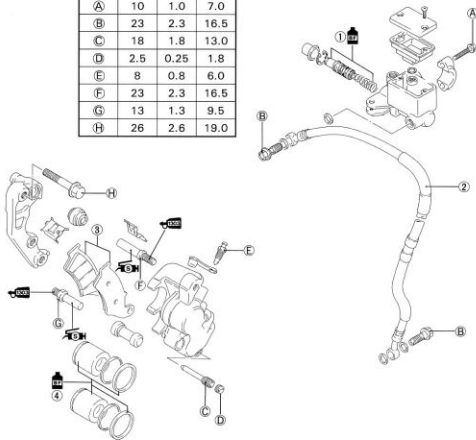

ITEM	N-m	kg-m	lb-ft
(A)	10	1.0	7.0
(B)	23	2.3	16.5
(C)	18	1.8	13.0
(D)	2.5	0.25	1.8
(E)	8	0.8	6.0
(F)	23	2.3	16.5
(G)	13	1.3	9.5
(H)	26	2.6	19.0

**▲ WARNING**

- \* This brake system is filled with a ethylene glycol-based DOT 4 brake fluid. Do not use or mix different types of fluid such as silicone-based or petroleum-based.
- \* Do not use any brake fluid taken from old, used or unsealed containers. Never reuse brake fluid left over from the last servicing or stored for long periods.
- \* When storing the brake fluid, seal the container completely and keep away from children.
- \* When replenishing brake fluid, take care not to get dust into fluid.
- \* When washing brake components, use fresh brake fluid. Never use cleaning solvent.
- \* A contaminated brake disc or brake pad reduces braking performance. Discard contaminated pads and clean the disc with high quality brake cleaner or neutral detergent.

**▲ CAUTION**

Handle brake fluid with care: the fluid reacts chemically with paint, plastics rubber materials etc.

## BRAKE PAD REPLACEMENT

- Remove the plug ①.
- Remove the brake pads by removing the mounting pin ②.

### CAUTION

- \* Do not operate the brake lever while dismantling the pads.
- \* Replace the brake pad as a set, otherwise braking performance will be adversely affected.

- Install the new pads.

### WARNING

Make sure that the pads are properly engaged with the guide plates as shown in photo.

- Tighten the pad mounting pin ② and plug ① to the specified torque.

-  Pad mounting pin: 18 N·m (1.8 kg·m, 13.0 lb·ft)  
 Plug: 2.5 N·m (0.25 kg·m, 1.8 lb·ft)

### NOTE:

After replacing the brake pads, pump with the brake lever few times to operate the brake correctly and then check the brake fluid level.

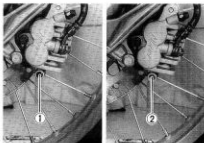

## BRAKE FLUID REPLACEMENT

- Place the motorcycle on a level surface and keep the handlebars straight.
- Remove the master cylinder reservoir cap and diaphragm.
- Suck up the old brake fluid as much as possible.
- Fill the reservoir with fresh brake fluid.

 Specification and classification: DOT 4

- Connect a clear hose ③ to the air bleeder valve ④, and insert the free end of hose into a receptacle.
- Loosen the bleeder valve and pump the brake lever until no more old brake fluid flows out of the bleeder valve.
- Close the air bleeder valve, and disconnect a clear hose. Fill the reservoir with fresh brake fluid to the upper end of the inspection window.

### CAUTION

Bleed air in the brake fluid circuit. (Refer to page 2-11.)

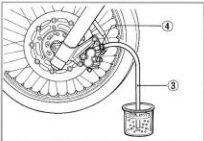

## CALIPER REMOVAL AND DISASSEMBLY

- Disconnect the brake hose by removing the union bolt and catch the brake fluid in a suitable receptacle.
- Remove the caliper by removing the mounting bolts.

### ⚠ CAUTION

Never reuse the brake fluid left over from previous servicing and stored for long periods.

### ⚠ WARNING

Brake fluid, if it leaks, will interfere with safe running and discolor painted surfaces.

Check the brake hose and hose joints for cracks and oil leakage.

- Remove the brake pad. (Refer to page 5-7.)
- Remove the caliper holder ① and spring ②.

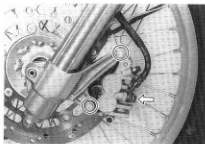

- Place a rag over the piston to prevent its popping out and push out the pistons with an air gun.

### ⚠ CAUTION

Do not use high pressure air to prevent piston damage.

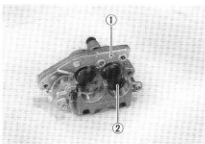

- Remove the dust seals and piston seals.

### ⚠ CAUTION

Do not reuse the removed seals to prevent fluid leakage.

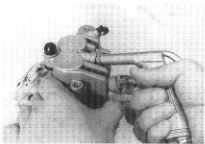

## CALIPER INSPECTION

Inspect the caliper cylinder wall for nicks, scratches or other damage.

Inspect the piston surface for any scratches or other damage.

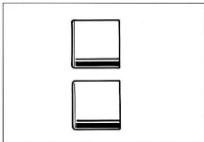
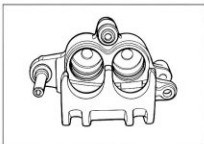

## CALIPER REASSEMBLY AND REMOUNTING

Reassemble and remount the caliper in the reverse order of removal and disassembly. Pay attention to the following points:

- Wash the caliper bores and pistons with specified brake fluid. Particularly wash the dust seal grooves and piston seal grooves.

 Specification and classification: DOT 4

### CAUTION

- \* Wash the caliper components with fresh brake fluid before reassembly.
- \* Do not wipe the brake fluid off after washing the components.
- \* When washing the components, use the specified brake fluid. Never use different types of fluid or cleaning solvent such as gasoline, kerosine or the others.
- \* Replace the piston seals and dust seals with new ones when reassembly. Apply the brake fluid to both seals when installing them.

- Apply SUZUKI SILICONE GREASE to the caliper axles.

 99000-25100: SUZUKI SILICONE GREASE



- Tighten each bolt to the specified torque.

- U** Caliper mounting bolt ①: 26 N·m (2.6 kg-m, 19.0 lb-ft)  
 Pad mounting pin ②: 18 N·m (1.8 kg-m, 13.0 lb-ft)  
 Plug ③: 2.5 N·m (0.25 kg-m, 1.8 lb-ft)  
 Brake hose union bolt ④: 23 N·m (2.3 kg-m, 16.5 lb-ft)  
 Air bleeder valve ⑤: 8 N·m (0.8 kg-m, 6.0 lb-ft)

**NOTE:**

Before remounting the caliper, push the piston all the way into the caliper.

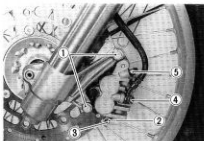

**CAUTION**

Bleed air from the system after reassembling the caliper.  
 (Refer to page 2-11.)

## BRAKE DISC INSPECTION

- Remove the front and rear wheels. (Refer to pages 5-2 and 5-27.)

Visually check the brake disc for damage or cracks.

Measure the thickness with a micrometer.

Replace the disc if the thickness is less than the service limit or if damage is found.

**LEOON** 09900-20205: Micrometer (0–25 mm)

**Service Limit**

Front disc: 3.5 mm (0.14 in)

Rear disc : 4.0 mm (0.16 in)

Measure the runout with a dial gauge.

Replace the disc if the runout exceeds the service limit.

**LEOON** 09900-20606: Dial gauge (1/100 mm)

09900-20701: Magnetic stand

**Service Limit**

Front and Rear disc: 0.3 mm (0.012 in)

- Remove the disc. (Refer to pages 5-3 and 5-29.)
- Install the disc. (Refer to pages 5-5 and 5-32.)

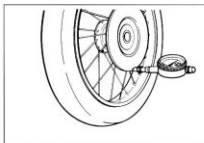
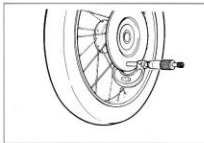

## MASTER CYLINDER REMOVAL AND DISASSEMBLY

- Remove the brake lever cover and rear view mirror.



- Remove the brake lever.
- Disconnect the front brake switch lead wires.

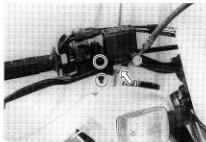

- Place a rag underneath the union bolt on the master cylinder to catch any spilled drops of brake fluid. Remove the union bolt and disconnect the brake hose/master cylinder joint.



### **CAUTION**

Immediately and completely wipe off any brake fluid contacting any part of the motorcycle. The fluid reacts chemically with paint, plastics and rubber materials, etc. and will damage them severely.

- Remove the master cylinder assembly.

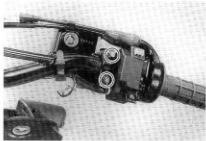

- Remove the front brake switch.



- Remove the reservoir cap and diaphragm.
- Drain brake fluid.

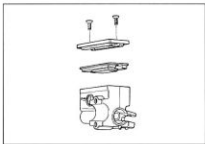

- Remove the dust boot.
- Remove the circlip with the special tool.

 **09900-06108: Snap ring pliers**

- Remove the piston/secondary cup, primary cup and spring.

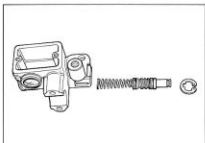

## MASTER CYLINDER INSPECTION

Inspect the master cylinder bore for any scratches or other damage.

Inspect the piston surface for any scratches or other damage.

Inspect the primary cup, secondary cup and dust seal for wear or damage.

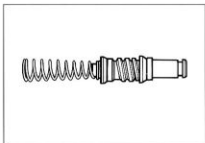
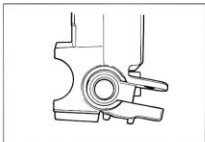

## MASTER CYLINDER REASSEMBLY AND REMOUNTING

Reassemble the master cylinder in the reverse order of removal and disassembly. Pay attention to the following points:

### CAUTION

- Wash the master cylinder components with fresh brake fluid before reassembly. Never use cleaning solvent or gasoline to wash them.
- Do not wipe the components with a rag.
- Apply brake fluid to the cylinder bore and all the component to be inserted into the bore.

**BP** Specification and classification: DOT 4

- When remounting the master cylinder on the handlebars, align the master cylinder holder's lower mating surface ① with punched mark ② on the handlebars and tighten the upper clamp bolt first as shown.

**U** Master cylinder mounting bolt:  
10 N·m (1.0 kg·m, 7.0 lb·ft)

### CAUTION

Bleed air from the system after reassembling master cylinder. (Refer to page 2-11.)

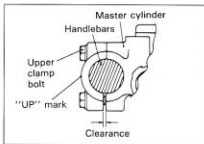
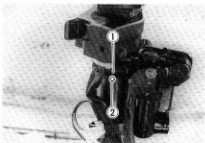
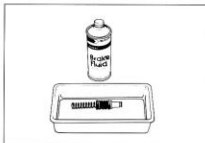



## FRONT FORK

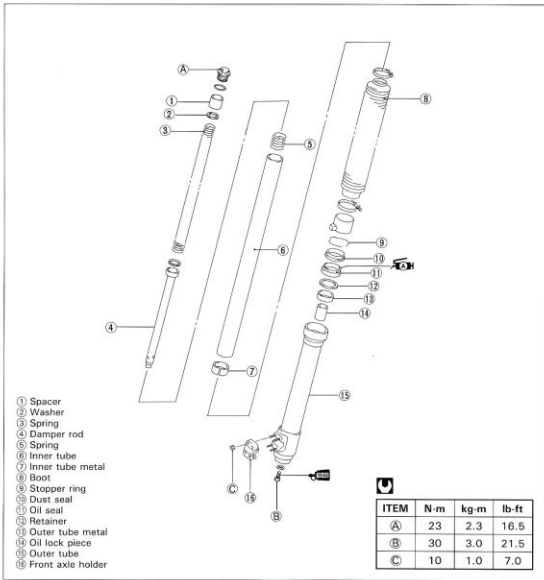

## REMOVAL AND DISASSEMBLY

- Remove the front wheel. (Refer to page 5-2.)
- Remove the front brake caliper. (Refer to page 5-8.)
- Remove the front brake hose clamp ①.
- Remove the speedometer cable guide bolt ②.

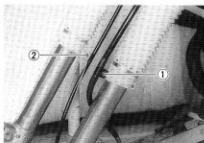

- Slightly loosen the front fork cap bolt ① after loosening the front fork upper clamp bolt ② to facilitate later disassembly.
- Remove the front fork by loosening the lower clamp bolts ③.

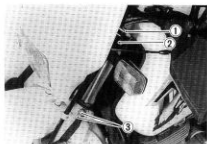

- Remove the front fork cap bolt ①, spacer ④, washer ⑤ and spring ⑥.

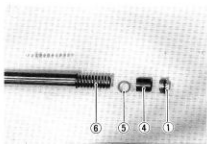

- Invert the fork and stroke it several times to drain fork oil.
- Hold the fork inverted for a few minutes to drain fork oil.

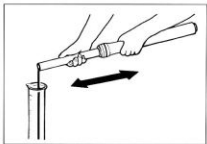

- Remove the damper rod bolt with a 8 mm hexagon wrench and special tools.

 09940-34520: "T" handle  
09940-34592: Attachment "G"

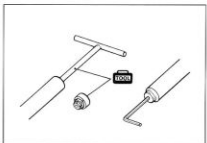

- Remove the damper rod with spring.

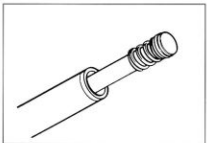

- Remove the boot by loosening the clamp screws.

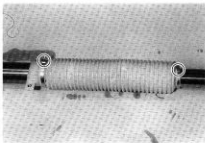

- Remove the dust seal stopper ring.



- Separate the inner tube from the outer tube.

#### CAUTION

- The removed dust seal and oil seal should be replaced.
- When separating the inner tube from the outer tube, both anti-friction metals may be damaged and must be replaced with new ones.

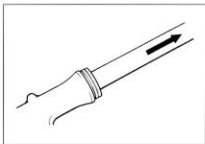

## INSPECTION

### FORK SPRING

Measure the fork spring free length. If it is shorter than service limit, replace it.

**Service Limit: 548 mm (21.6 in)**



### INNER TUBE AND OUTER TUBE

Inspect the inner tube sliding surface for any scuffing and check for bend. Inspect the outer tube sliding surface for any scuffing.

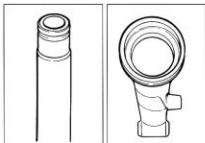

**DAMPER ROD RING**

Inspect the damper rod ring for wear or damage.

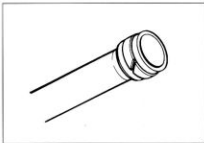
**REASSEMBLY AND REMOUNTING**

Reassemble and remount the front fork in the reverse order of removal and disassembly, and also carry out the following steps:

**INNER TUBE METAL**

- Install the metal by hand as shown in the illustration.

**CAUTION**

Use special care to prevent damage to the "Teflon" coated surface of the Anti-friction metal when mounting it.

**OUTER TUBE METAL, OIL SEAL AND DUST SEAL**

- Clean the metal groove of outer tube and metal outer surface.
- Apply grease to the lip of new oil seal ③.

 99000-25030: SUZUKI SUPER GREASE "A"

- Install the outer tube metal ①, oil seal retainer ②, oil seal ③ and dust seal ④.

 09940-52860: Front fork oil seal installer

**CAUTION**

Use special care to prevent damage to the "Teflon" coated surface of the Anti-friction metal when mounting it.

- Install the dust seal stopper ring ⑤.

**CAUTION**

Make sure that the oil seal stopper ring fitted securely.

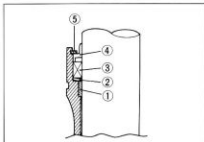
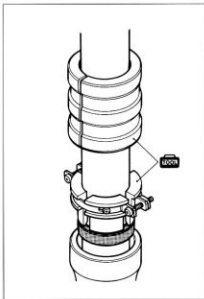

**DAMPER ROD BOLT**

Apply **THREAD LOCK "1342"** to the damper rod bolt and tighten it to the specified torque with the special tools and 8-mm hexagon wrench.

 **99000-32050: THREAD LOCK "1342"**

 **09940-34520: "T" handle**

**09940-34592: Attachment "G"**

 **Damper rod bolt: 30 N-m (3.0 kg-m, 21.5 lb-ft)**

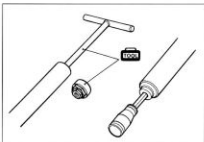
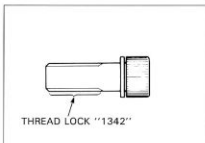
**FORK OIL**

- For the fork oil, be sure to use a front fork oil whose viscosity rating meets specifications below.

**Fork oil type: Fork oil # 10**

**Fork oil capacity: 565 ml (19.1/19.9 US/Imp oz)**

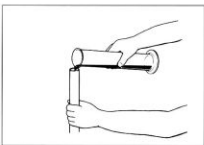

- Hold the front fork vertical and adjust the fork oil level with the special tool.

**NOTE:**

*When adjusting oil level, remove the fork spring and compress the inner tube fully.*

 **09943-74111: Fork oil level gauge**

**Oil level: 164 mm (6.5 in)**

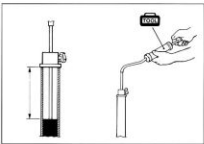
**FORK SPRING**

- Install the fork spring close pitch side up.



**FRONT FORK REMOUNTING**

- Align the top surface ① of the inner tube to the top surface ② of the steering stem upper bracket.

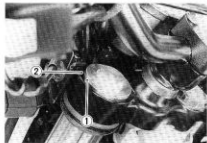

- Tighten each bolt to the specified torque.

- U** Front fork cap bolt ③: 23 N·m (2.3 kg-m, 16.5 lb-ft)  
Upper clamp bolt ④: 29 N·m (2.9 kg-m, 21.0 lb-ft)  
Lower clamp bolt ⑤: 26 N·m (2.6 kg-m, 19.0 lb-ft)

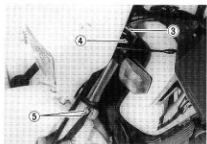

## STEERING

- ① Handlebar clamp
- ② Handlebar holder
- ③ Cap
- ④ Damper (Upper)
- ⑤ Steering stem upper bracket
- ⑥ Damper (Lower)
- ⑦ Steering stem nut
- ⑧ Bearing (Upper)
- ⑨ Bearing (Lower)
- ⑩ Steering stem lower bracket

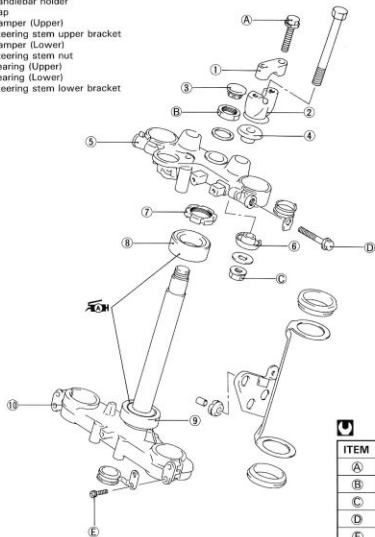

ITEM	N-m	kg-m	lb-ft
Ⓐ	23	2.3	16.5
Ⓑ	90	9.0	65.0
Ⓒ	25	2.5	18.0
Ⓓ	29	2.9	21.0
Ⓔ	26	2.6	19.0

## REMOVAL AND DISASSEMBLY

- Remove the front wheel. (Refer to page 5-2.)
- Remove the front fork. (Refer to page 5-14.)
- Remove the speedometer cable clamp and the front fender.

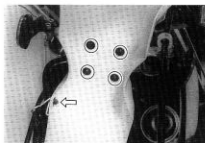

- Remove the headlight cover by removing the three screws.



- Remove the lead wire cover ①.
- Disconnect each lead wire coupler.

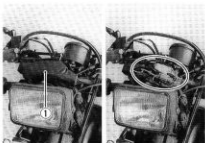

- Remove the headlight bracket with headlight by removing the four bolts.



- Remove the front brake master cylinder with brake hose.
- Remove the left turn signal light.

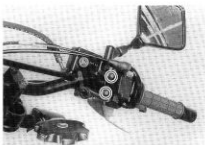



- Unlock the clamps.
- Remove the right turn signal light.

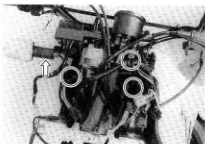

- Remove the headlight bracket holders.



- Remove the speedometer cable ①.
- Remove the speedometer by removing the nuts.

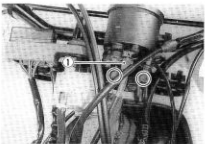

- Remove the throttle grip case screws.
- Disconnect the throttle cables.

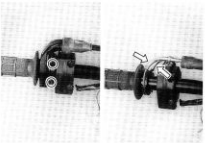

- Remove the left handlebar switch case screws.
- Disconnect the starter cable.

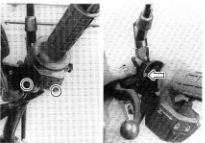

- Remove the clutch lever cover.
- Remove the clutch cable ①.



- Remove the indicator light panel ②.

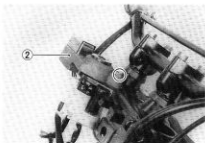

- Remove the ignition switch mounting bolts with the special tools.

 09930-11920: Torx bit JT40H  
09930-11940: Bit holder

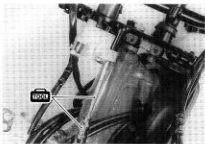

- Remove the handlebars by removing the four mounting bolts.

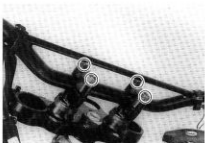

- Remove the handlebar holder by removing the mounting nuts.

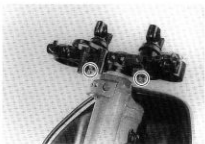

- Remove the steering stem upper bracket by removing the stem head nut.



- Loosen the steering stem nut with the special tools.

**MOON** 09940-14911: Steering stem nut socket wrench  
09940-14960: Steering stem nut socket

- Remove the steering stem lower bracket.

**NOTE:**

Hold the steering stem lower bracket by hand to prevent it from falling.



- Remove the upper bearing.



- Remove the steering stem lower bearing with a chisel.

**CAUTION**

The removed bearing should be replaced with a new one.

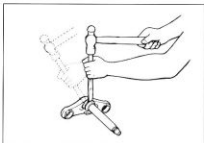

- Remove the steering stem bearing races, upper and lower with the special tools.

**MOON** 09941-54911: Steering race remover  
09941-74910: Steering bearing remover and installer

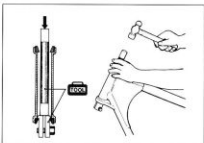

## INSPECTION

Inspect the removed parts for the following abnormalities.

- \* Handlebars distortion
- \* Handlebar clamp wear
- \* Race wear and brinelling
- \* Abnormal noise of bearing
- \* Distortion of steering stem

Inspect the play of dampers by hands while fixing it in the steering stem upper bracket. If the play can be found, replace the dampers.

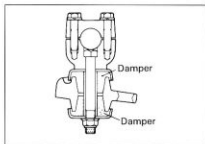

## REASSEMBLY AND REMOUNTING

Reassemble and remount the steering stem in the reverse order of removal and disassembly. Pay attention to the following points:

### BEARING RACES

- Press in the upper and lower bearing races with the special tool.

 09941-34513: Steering outer race installer

### BEARING

- Press in the lower bearing with the special tool.

 09925-18010: Steering bearing installer

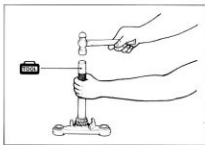
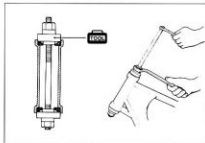

- Apply grease to the upper and lower bearings.

 099000-25030: SUZUKI SUPER GREASE "A"

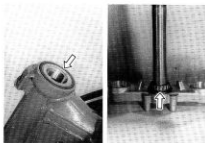

### STEM NUT

- Tighten the steering stem nut to 45 N·m (4.5 kg·m, 32.5 lb-ft) with the special tools.

 09940-14911: Steering stem nut wrench  
09940-14960: Steering stem nut socket



- Turn the steering stem bracket about five or six times to the left and right until it locks in position so that the taper roller bearing will be seated properly.
- Turn back the stem nut by 1/4–1/2 turn.

**NOTE:**

*This adjustment will vary from motorcycle to motorcycle.*

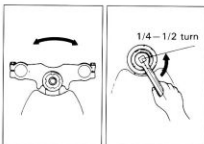

- Tighten the steering stem nut to the specified torque.

**U** Steering stem head nut: 90 N·m (9.0 kg·m, 65.0 lb-ft)

**NOTE:**

*Before tightening the steering stem nut, install the front fork temporarily.*

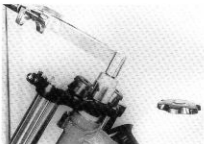

- Tighten the handlebar holder nuts to the specified torque.

**U** Handlebar holder nut: 25 N·m (2.5 kg·m, 18.0 lb-ft)

**NOTE:**

*Before tighten the handlebar holder nuts, install the handlebars temporarily.*

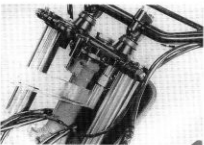
**HANDLEBARS**

- Set the handlebars to match its punched mark to the mating face of the holder.
- Secure the each handlebar clamp in such a way that the clearances (A) ahead and behind of the handlebars are equalized.

**U** Handlebar clamp bolt: 23 N·m (2.3 kg·m, 16.5 lb-ft)

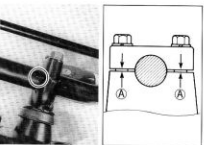
**CAUTION**

After performing the adjustment and installing the steering stem upper bracket, “rock” the front wheel assembly forward and back to ensure that there is no play and that the procedure was accomplished correctly. Finally check to be sure that the steering stem moves freely from left to right with own weight. If play or stiffness is noticeable, re-adjust the steering stem nut.

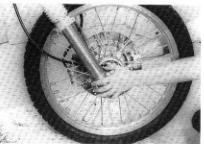

## REAR WHEEL

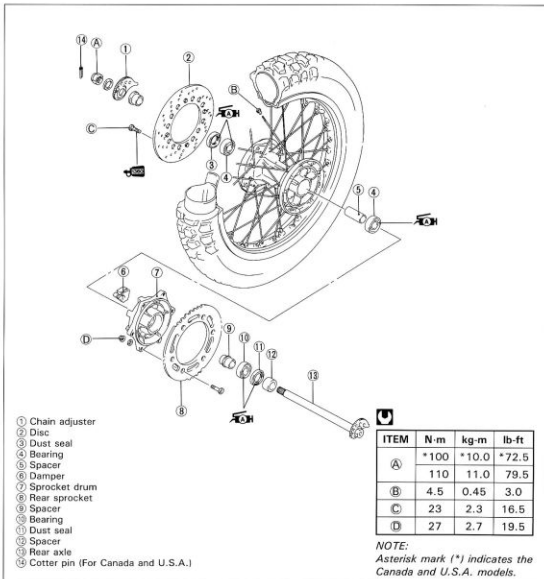

## REMOVAL

- Remove the cotter pin. (For Canada and U.S.A.)
- Loosen the axle nut.
- Support the motorcycle with a jack.
- Remove the axle nut and axle.

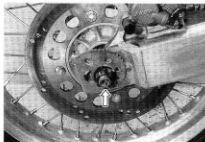

- Remove the rear wheel by disengaging the drive chain.

**CAUTION**

Do not operate the brake pedal while dismantling the rear wheel.

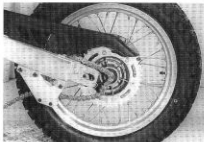

- Remove the rear sprocket mounting drum from the wheel.

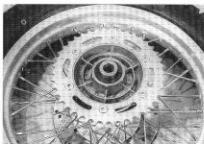

- Remove the cushions.

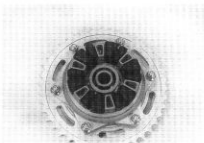

- Remove the spacer ①.
- Remove the rear sprocket by removing the mounting nuts and bolts.

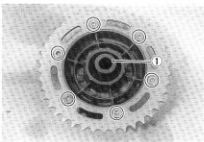

- Remove the dust seal with the special tool.

 09913-50121: Dust seal remover

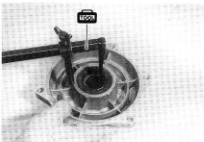

- Remove the brake disc by removing the mounting bolts.



## INSPECTION AND DISASSEMBLY

TIRE ..... Refer to page 2-12.

REAR WHEEL ..... Refer to page 5-10.

### WHEEL BEARING AND SPROCKET DRUM BEARING

Inspect the play of bearing inner ring by hand while mounted in the wheel or sprocket drum. Rotate the inner ring by hand to inspect any abnormal noise occurs or rotating smoothly. Replace the bearing if there is anything unusual.

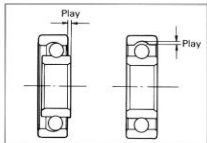

Remove the both bearing with the special tool in the following procedures.

- Insert the adapter into the bearing.

 09941-50111: Bearing remover



- After inserting the wedge bar from the opposite side, lock the wedge bar in the slit of the adapter.
- Drive out the bearing by hammering the wedge bar.

### CAUTION

The removed bearings should be replaced with new ones.

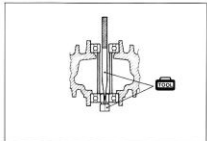



- Remove the sprocket drum bearing with the special tool.

 09913-75830: Bearing remover

**CAUTION**

The removed bearing should be replaced with a new one.



### REAR AXLE

Using a dial gauge, check the rear axle for runout. If the runout exceeds the limit, replace the rear axle.

 09900-20606: Dial gauge (1/100 mm)  
09900-20701: Magnetic stand  
09900-21304: "V" block set

Service Limit: 0.25 mm (0.010 in)

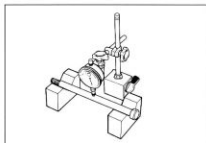

### REAR SPROCKET

Inspect the sprocket teeth for wear. If they are worn as illustrated, replace the sprocket and drive chain.

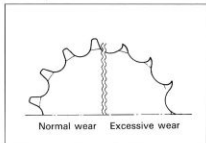

### REAR SPROCKET DAMPER

Inspect the dampers for wear and damage. If any defects are found, replace the dampers as a set.

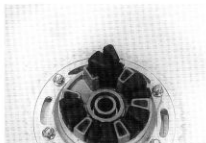

## REASSEMBLY AND REMOUNTING

Reassemble and remount the rear wheel in the reverse order of removal and disassembly. Pay attention to the following points:

### WHEEL BEARING

- Apply grease to the bearings.

 099000-25030: SUZUKI SUPER GREASE "A"

- Install the wheel bearings with the special tools.

 09924-84510: Bearing installer  
09924-84521: Bearing installer

#### NOTE:

First install the bearing for right side. Seal side of bearing goes toward outside.

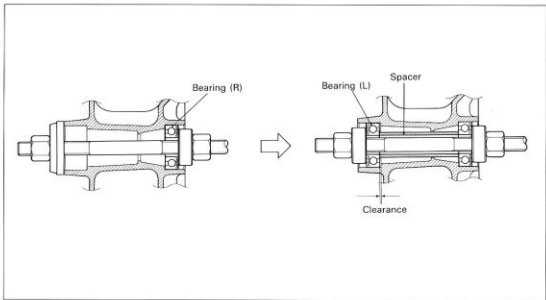
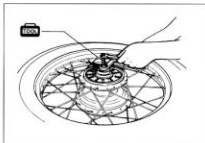

- Install the rear sprocket drum bearing by using a bearing installer.

 09913-75810: Bearing installer

#### NOTE:

Seal side of bearing goes toward outside.

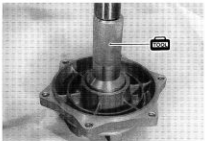

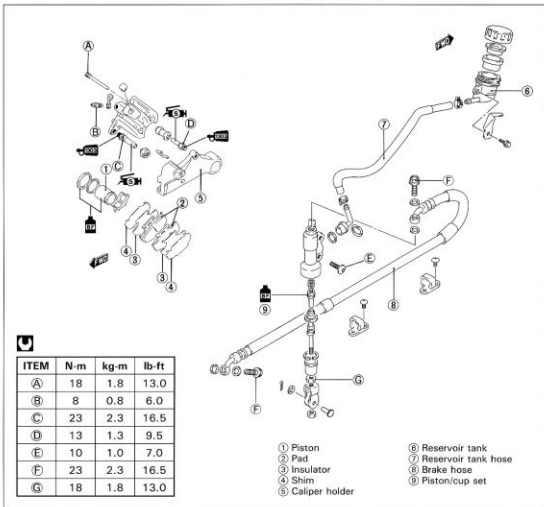

## REAR BRAKE

**▲ WARNING**

- \* This brake system is filled with a ethylene glycol-based DOT 4 brake fluid. Do not use or mix different types of fluid such as silicone-based or petroleum-based.
- \* Do not use any brake fluid taken from old, used or unsealed containers. Never reuse brake fluid left over from the last servicing or stored for long periods.
- \* When storing the brake fluid, seal the container completely and keep away from children.
- \* When replenishing brake fluid, take care not to get dust into fluid.
- \* When washing brake components, use fresh brake fluid. Never use cleaning solvent.
- \* A contaminated brake disc or brake pad reduces braking performance. Discard contaminated pads and clean the disc with high quality brake cleaner or neutral detergent.

**▲ CAUTION**

Handle brake fluid with care: the fluid reacts chemically with paint, plastics, rubber materials etc.

## BRAKE PAD REPLACEMENT

- Remove the brake pad mounting pins ①.
- Remove the inside pad first.

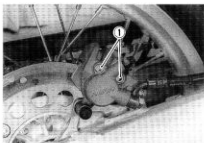

- Slide the caliper housing to outside then remove the pad ②.

### CAUTION

- Do not operate the brake pedal while dismantling the pads.
- Replace the brake pad as a set, otherwise braking performance will be adversely affected.

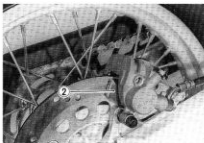

- Install the new pads correctly.
- Tighten the pad mounting pin ① to the specified torque.

 Pad mounting pin: 18 N·m (1.8 kg-m, 13.0 lb-ft)

### NOTE:

After replacing the brake pads, pump with brake pedal few times to operate the brake correctly and then check the brake fluid level.

## BRAKE FLUID REPLACEMENT

- Remove the reservoir tank mounting bolt.
- Replace brake fluid in the same manner of the front brake.  
(Refer to page 5-7.)

 Specification and classification: DOT 4

### CAUTION

Bleed air in the brake fluid circuit. (Refer to page 2-11.)

**CALIPER REMOVAL AND DISASSEMBLY**

- Remove the rear wheel. (Refer to page 5-27.)
- Place a rag underneath the union bolt on the brake caliper to catch any spilled drops of brake fluid.
- Remove the union bolt and catch brake fluid in a suitable receptacle.

**CAUTION**

Never reuse the brake fluid left over from previous servicing and stored for long periods.

**WARNING**

Brake fluid, if it leaks, will interfere with safe running and discolor painted surfaces. Check the brake hose and hose joints for cracks and fluid leakage.

- Remove the caliper with caliper holder.
- Remove the caliper holder ①.
- Remove the pads. (Refer to page 5-34.)

- Place a rag over the piston to prevent popping up. Force out the piston with an air gun.

**CAUTION**

Do not use high pressure air to prevent piston damage.

- Remove the dust seal and piston seal.

**CAUTION**

Do not reuse the removed seals to prevent fluid leakage.

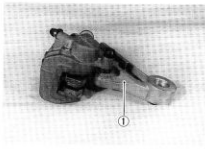

## CALIPER AND DISC INSPECTION

Inspect the caliper cylinder bore wall for nicks, scratches or other damage.

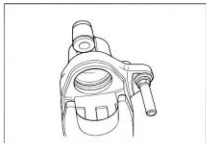

Inspect the pistons for damage and wear.

**DISC** ..... Refer to page 5-10.

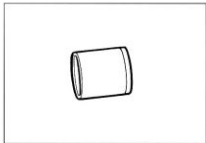

## CALIPER REASSEMBLY AND REMOUNTING

Reassemble and remount the caliper in the reverse order of removal and disassembly. Pay attention to the following points:

### ⚠ CAUTION

- \* Wash the caliper components with fresh brake fluid before reassembly. Never use cleaning solvent or gasoline to wash them.
- \* Apply brake fluid to the caliper bore and piston to be inserted into the bore.



 Specification and classification: DOT 4

- Tighten the brake hose union bolt to the specified torque.

 Brake hose union bolt: 23 N·m (2.3 kg·m, 16.5 lb-ft)

### ⚠ CAUTION

Bleed air from the system after reassembling the caliper.  
(Refer to page 2-11.)

## MASTER CYLINDER REMOVAL AND DISASSEMBLY

- Place a cloth underneath the union bolt on the master cylinder to catch spilled drops of brake fluid.



- Loosen the rear brake rod lock nut ①.
- Remove the master cylinder mounting bolts ②.
- Disconnect the brake rod by rotating brake rod ③.

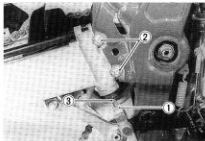

- Disconnect the brake hose ④.
- Remove the reservoir tank by removing the mounting bolt ⑤.

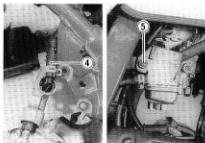

- Remove the connector by removing the circlip ⑥.

 09900-06108: Snap ring pliers

- Remove the O-ring ⑦.

### CAUTION

The removed O-ring should be replaced with a new one.

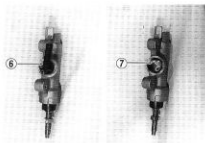

- Remove the dust boot.
- Remove the circlip with the special tool.

 09900-06108: Snap ring pliers

- Remove the rod, piston, primary cup and spring.

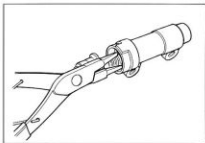



## MASTER CYLINDER INSPECTION

Inspect the cylinder bore wall for any scratches or other damage.



Inspect the piston surface for scratches or other damage.  
Inspect the primary cup for damage.

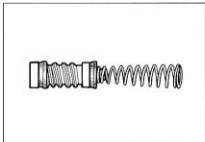



## MASTER CYLINDER REASSEMBLY AND REMOUNTING

Reassemble and remount the master cylinder in the reverse order of removal and disassembly. Pay attention to the following points:

### CAUTION

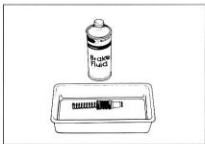
- \* Wash the master cylinder components with fresh brake fluid before reassembly. Never use cleaning solvent or gasoline to wash them.
- \* Apply brake fluid to the cylinder bore and all the internals to be inserted into the bore.



 Specification and classification: DOT 4

### MASTER CYLINDER

- Tighten the bolts and nut to the specified torque.

-  Master cylinder mounting bolt ① : 10 N-m (1.0 kg-m, 7.0 lb-ft)
- Master cylinder rod lock nut ② : 18 N-m (1.8 kg-m, 13.0 lb-ft)
- Brake hose
- Union bolt ③ : 23 N-m (2.3 kg-m, 16.5 lb-ft)

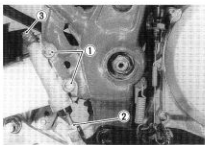

### CAUTION

- \* Bleed air from the system after reassembling master cylinder. (Refer to page 2-11.)
- \* Adjust the brake pedal height. (Refer to page 2-11.)

## REAR SWINGARM AND SUSPENSION

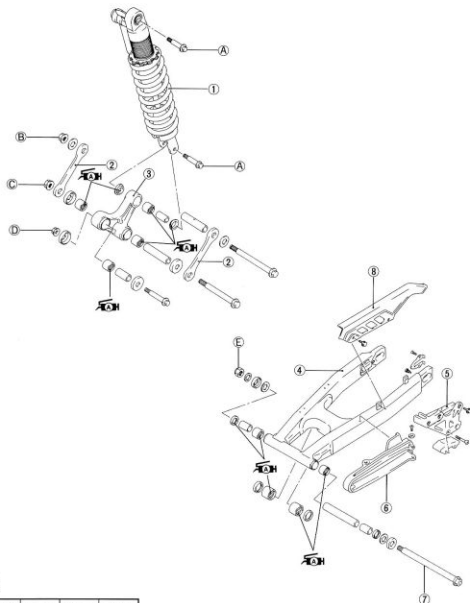

ITEM	N-m	kg-m	lb-ft
(A)	55	5.5	40.0
(B)	100	10.0	72.5
(C)	100	10.0	72.5
(D)	80	8.0	58.0
(E)	77	7.7	55.5

- ① Shock absorber
- ② Cushion rod
- ③ Cushion lever
- ④ Swingarm
- ⑤ Chain guide
- ⑥ Chain buffer
- ⑦ Rear axle
- ⑧ Chain cover

**REMOVAL**

- Remove the frame covers and seat. (Refer to page 5-1.)
- Remove the rear wheel. (Refer to page 5-27.)
- Loosen the carburetor clamp screw ①.
- Disconnect the crankcase breather hose ②.

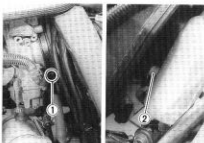

- Remove the air cleaner by removing the mounting bolts ③.

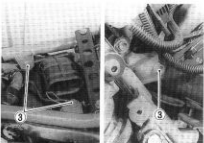

- Disconnect the brake hose from the hose guides.



- Remove the drive chain cover and guide.

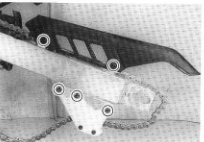

- Remove the rear shock absorber lower mounting bolt ④.
- Remove the cushion lever mounting nut ⑤ and bolt.

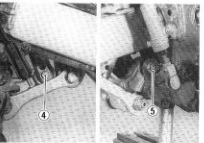

## 5-41 CHASSIS

---

- Remove the rear swingarm pivot nut after removing the caps.
- Remove the rear swingarm by removing the pivot shaft.

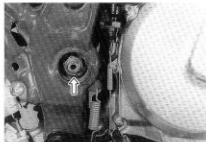

- Remove the rear shock absorber.

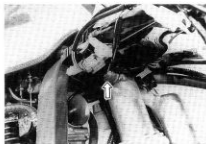

- Remove the cushion rods with cushion lever.

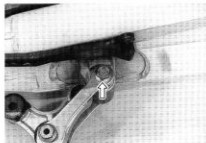

- Remove the drive chain buffer.

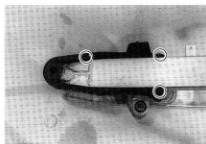

- Remove the brake hose guides and mud guard.

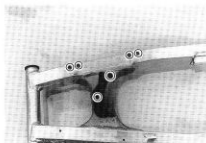

- Remove the cushion rods.



- Remove the swingarm dust seals and spacers.

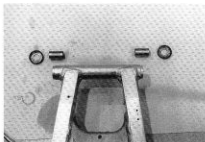

- Remove the cushion lever dust seals and spacers.



## INSPECTION AND DISASSEMBLY

### SWINGARM

Inspect the swingarm for wear or damage.

Inspect the spacer for any flaws or other damage.

Insert the spacer into the bearing and check the play to move the spacer up and down.

If an excessive play is noted, replace the bearing with a new one.



- Draw out the swingarm bearings and spacer with the special tools.

 09923-74510: Bearing remover  
09930-30102: Sliding shaft

#### CAUTION

The removed bearings should be replaced with new ones.

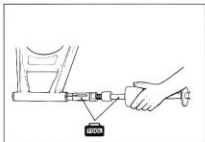

**CUSHION LEVER**

Inspect the spacer for any flaws or other damage. Insert the spacer into the bearing and check the play to move the spacer up and down. If an excessive play is noted, replace the bearing with new ones.

- Draw out the bearing with the special tools and appropriate tool.

 09923-73210: Bearing remover  
09930-30102: Sliding shaft

**CAUTION**

The removed bearing should be replaced with new ones.

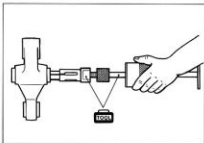
**SHOCK ABSORBER**

Inspect the shock absorber for oil leakage or other damage. If any defects are found, replace the shock absorber with new one.

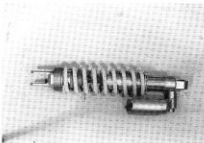
**SWINGARM PIVOT SHAFT**

Using a dial gauge, check the pivot shaft runout and replace it if the runout exceeds the limit.

 09900-20606: Dial gauge  
09900-20701: Magnetic stand  
09900-21304: V-block

Service Limit: 0.3 mm (0.01 in)

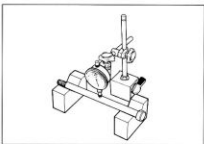

## REASSEMBLY AND REMOUNTING

Reassemble and remount the rear swingarm and suspension in the reverse order of removal and disassembly. Pay attention to the following points:

### SWINGARM BEARING

- Install the new bearing with the special tool.

 09941-34513: Bearing installer

**NOTE:**

*When installing the bearing, punch-marked side of bearing faces outside.*

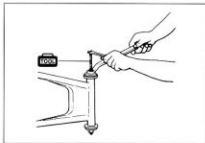

### CUSHION LEVER BEARING

- Install the new bearing with the special tool.

 09924-84521: Bearing installer

**NOTE:**

*When installing the bearing, punch-mark side of bearing faces outside.*

- Remount the rear suspension. (Refer to page 5-45.)

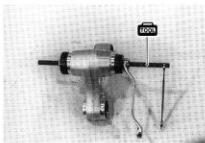

## REASSEMBLING INFORMATION

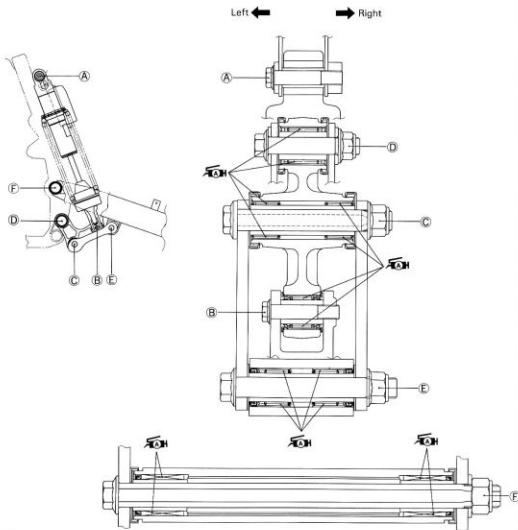

ITEM	N-m	kg-m	lb-ft
(A)	55	5.5	40.0
(B)	55	5.5	40.0
(C)	100	10.0	72.5
(D)	80	8.0	58.0
(E)	100	10.0	72.5
(F)	77	7.7	55.5



## FINAL INSPECTION AND ADJUSTMENT

After installing the rear suspension and wheel, the following adjustments are required before driving.

- \* Drive chain ..... Page 2- 9.
- \* Rear brake pedal height ..... Page 2-11.
- \* Tire pressure ..... Page 2-13.

### SHOCK ABSORBER SPRING PRE-LOAD ADJUSTMENT

Spring pre-load is adjustable by changing the spring adjuster ring position after removing the shock absorber. Turning the spring adjuster ring counterclockwise or clockwise as viewed from for increase or decrease the spring pre-load after loosening the adjuster lock ring. The standard set length is 247.5 mm.

After adjusting the pre-load, tighten the spring adjuster lock ring securely.

 09910-60611: Universal clamp wrench

#### CAUTION

Do not set the spring to the length less than 238.5 mm (9.4 in).

### SPRING SETTING TABLE

	Spring pre-set length
Softest	253.5 mm (10.0 in)
Standard	247.5 mm (9.7 in)
Stiffest	238.5 mm (9.4 in)

### SHOCK ABSORBER DAMPING FORCE ADJUSTMENT

Fully turn the damping force adjuster clockwise. It is at stiffest position and turn it out to the standard setting position.

STD position: 8 clicks turns out

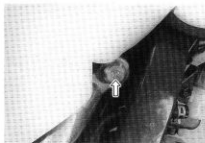
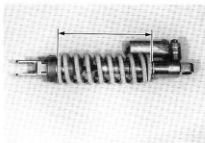
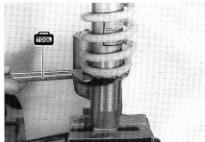

## LOWERING THE SEAT HEIGHT

The seat height can be lowered 40 mm by changing the location of the inner parts of the front fork and rear shock absorber and replace the optional side stand.



### OPTIONAL PARTS SUPPLY

Part No.	Part Name	PCS	Note	
42300-32820	Non	Side stand <b>(A)</b> (Silver painting)	1	For E-03 E-24 E-28 E-33
	09248-10006	Plug	1	
	62184-32E00	Plate	1	
	68380-32E10	Label set	1	
42300-32810	Non	Side stand <b>(B)</b> (Silver painting)	1	For the others
	09248-10006	Plug	1	
	62184-32E00	Plate	1	
	68380-32E00	Label set	1	

**NOTE:**

Side stand length **(A)** is different from **(B)** in the above chart.

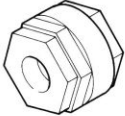
### SPECIAL TOOLS

 <p>This special tool is used for loosening and tightening the front fork damper rod bolt. 09940-34520: "T" handle</p>	 <p>This special tool is used with tool (09940-34520) for loosening and tightening the front fork damper rod bolt. 09940-34592: Attachment "G"</p>
 <p>This special tool is used for adjusting the front fork oil level. 09943-74111: Front fork oil level gauge</p>	 <p>This special tool is used for loosening and tightening the rear shock absorber ring. 09910-60611: Universal clamp wrench</p>

## FRONT FORK

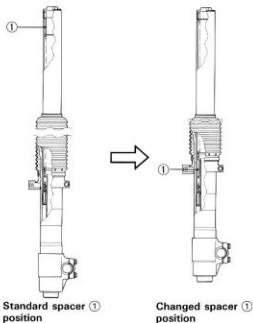
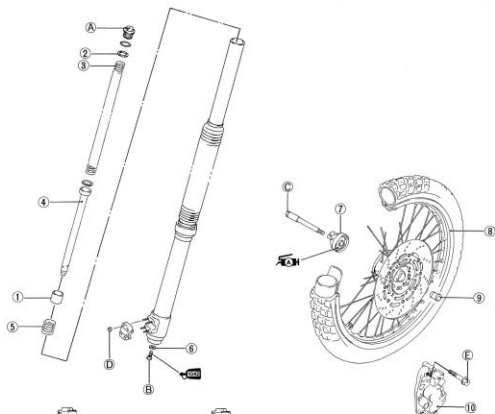

- ① Spacer
- ② Washer
- ③ Spring
- ④ Damper
- ⑤ Spring
- ⑥ Gasket
- ⑦ Speedometer gearbox
- ⑧ Front wheel
- ⑨ Spacer
- ⑩ Front brake caliper



ITEM	N-m	kg-m	lb-ft
Ⓐ	23	2.3	16.5
Ⓑ	30	3.0	21.5
Ⓒ	65	6.5	47.0
Ⓓ	10	1.0	7.0
Ⓔ	26	2.6	19.0

## REMOVAL AND DISASSEMBLY

- Loosen the front axle holder nuts ① and axle ②.
- Carefully position a jack under the chassis tubes and raise until the front wheel is slightly off the ground.
- Remove the front wheel by removing the axle.

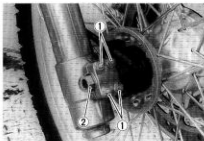

- Remove the front brake caliper mounting bolts ③.
- Remove the front brake hose clamp bolt ④ and speedometer cable guide bolt ⑤.

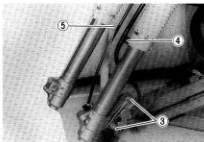

- Slightly loosen the front fork cap bolt ⑥ after loosening the front fork upper clamp bolt ⑦ to facilitate later disassembly.
- Remove the front fork by loosening the lower clamp bolts ⑧.
- Remove the other side front fork the same way.

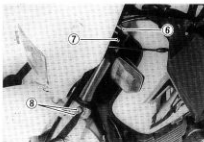

- Remove the front fork cap bolt ⑥, spacer ⑨, washer ⑩ and spring ⑪.

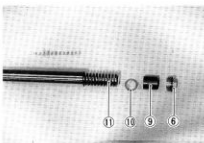

- Invert the front fork and stroke it several times to drain fork oil.

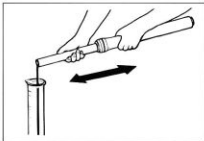

- Remove the damper rod bolt with a 8 mm hexagon wrench and special tools.

 09940-34520: "T" handle  
09940-34592: Attachment "G"

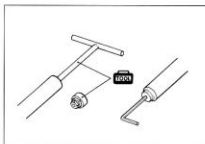

- Remove the damper rod ① with spring ②.

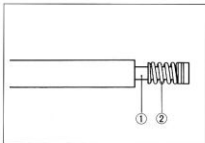

#### REASSEMBLY AND REMOUNTING

Reassemble and remount the front fork and front wheel in the reverse order of removal and disassembly. Pay attention to the following points:

- Install the removed spacer ③ and spring ② to the damper rod as shown in the photo.

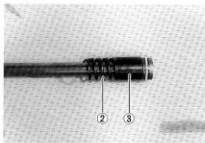

- Insert the damper rod assembly to the inner tube with the special tool.

 09940-34520: "T" handle  
09940-34592: Attachment "G"

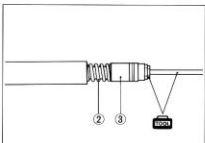

- Apply THREAD LOCK "1342" to the damper rod bolt.

 99000-32050: THREAD LOCK "1342"

#### CAUTION

Use a new gasket ④ to prevent oil leakage.

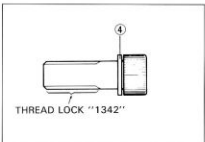

- Tighten the damper rod bolt to the specified torque with a 8 mm hexagon wrench and special tools.

 Damper rod bolt: 30 N·m (3.0 kg-m, 21.5 lb-ft)

 09940-34520: "T" handle  
09940-34592: Attachment "G"

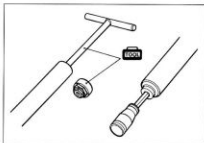

- Pour specified fork oil into the inner tube.

 Fork oil type: Fork oil # 10  
99000-99044-10G: SUZUKI FORK OIL # 10

Capacity (each leg): 563 ml (19.0/19.8 US/Imp oz)

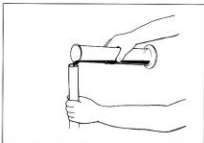

- Hold the front fork vertical and adjust the fork oil level with the special tool.

 09943-74111: Fork oil level gauge

Oil level: 150 mm (5.9 in)

**NOTE:**

When adjusting the oil level, remove the fork spring and compress the inner tube fully.

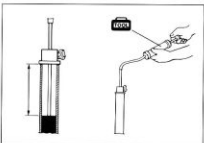

- Install the fork spring close pitch side up.
- Install the washer and fork cap bolt, and tighten the cap bolt your hand.

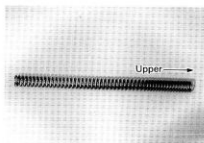

- When remounting the front fork, align the upper surface ① of the inner tube with the upper surface ② of the steering stem upper bracket.

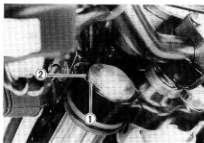

- Tighten the front fork lower clamp bolts and fork cap bolt to the specified torque.
- Tighten the front fork upper clamp bolt to the specified torque.

**🔧** Front fork cap bolt: 23 N·m (2.3 kg-m, 16.5 lb-ft)  
 Upper clamp bolt : 29 N·m (2.9 kg-m, 21.0 lb-ft)  
 Lower clamp bolt : 26 N·m (2.6 kg-m, 19.0 lb-ft)

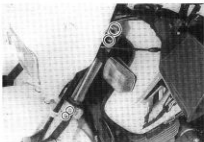

- Install the brake hose clamp and speedometer cable guide correctly.
- Tighten the front brake caliper mounting bolts to the specified torque.

**🔧** Brake caliper mounting bolt: 26 N·m  
 (2.6 kg-m, 19.0 lb-ft)

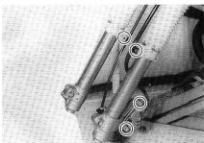

- Align the drive lugs ① with the recesses ② of the wheel hub.

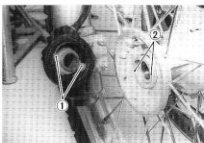

- Before tightening the front axle, position the stopper ③ of the speedometer gearbox against stopper ④.

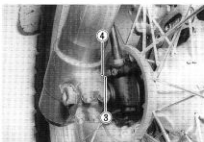

- Tighten the front axle to the specified torque and then move the front fork up and down.
- Tighten the upper axle holder nuts first and then lower nuts to the specified torque.

**🔧** Front axle: 65 N·m (6.5 kg-m, 47.0 lb-ft)  
 Axle holder nut: 10 N·m (1.0 kg-m, 7.0 lb-ft)

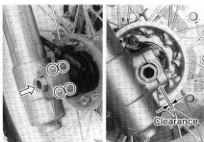

## REAR SHOCK ABSORBER

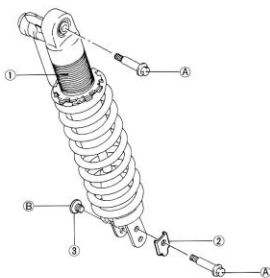

- ① Rear shock absorber
- ② Plate (Optional part)
- ③ Plug (Optional part)
- ④ Spring seat

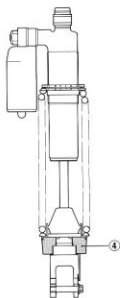

Standard spring seat ④ and mounting position

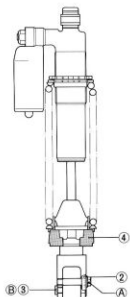

Changed spring seat ④ and mounting position.



ITEM	N-m	kg-m	lb-ft
Ⓐ	55	5.5	40.0
Ⓑ	30	3.0	21.5



**REMOVAL AND DISASSEMBLY**

- Remove the right and left frame covers.
- Remove the seat by removing mounting bolts.
- Loosen the carburetor clamp screw ①.
- Disconnect the crankcase breather hose ②.
- Remove the air cleaner by removing mounting bolts ③.
- Remove the rear shock absorber by removing mounting bolts ④, ⑤.

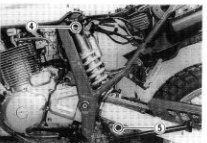
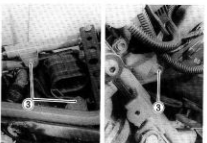
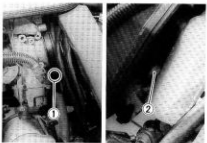
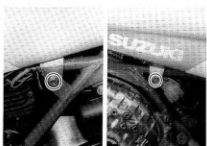
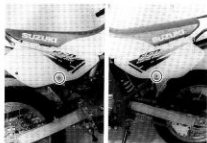

- Loosen the spring pre-load adjuster lock ring and adjuster ring fully with the special tool.

 09910-60611: Universal clamp wrench

- Remove the spring seat ① and plate ② by moving the cushion ③ to the shock absorber cylinder side.

**NOTE:**

The removed plate ② will not be used when reassembling the shock absorber.

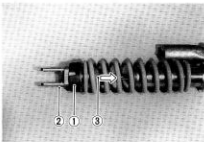
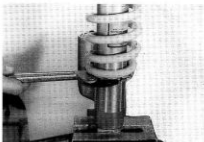

**REASSEMBLY AND REMOUNTING**

Reassemble and remount the rear shock absorber and air cleaner in the reverse order of removal and disassembly. Pay attention to the following points:

- When installing the spring seat ① to the shock absorber, invert it from standard position.

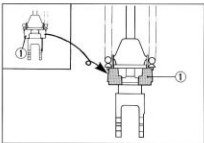

- Position the cushion ③ against washer ④.
- Tighten the spring adjuster ring and adjust the spring pre-load with the special tool. The standard set length is 247.5 mm.
- After adjusting the pre-load, tighten the adjuster lock ring securely.

 09910-60611: Universal clamp wrench

**SPRING SETTING TABLE**

	Spring pre-set length
Softest	253.5 mm (10.0 in)
Standard	247.5 mm (9.7 in)
Stiffest	238.5 mm (9.4 in)

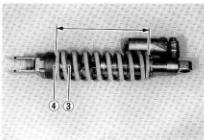

- Tighten the plug ① (optional part) to the lower mounting part of shock absorber ② to the specified torque.

**U** Plug: 30 N·m (3.0 kg·m, 21.5 lb-ft)

- Install the shock absorber lower plate ③ (optional part) as shown in the illustration.
- Install the rear shock absorber and tighten it to the specified torque.

**U** Mounting bolt : 55 N·m (5.5 kg·m, 40.0 lb-ft)  
(Upper and lower)

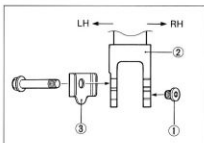

## SIDE STAND

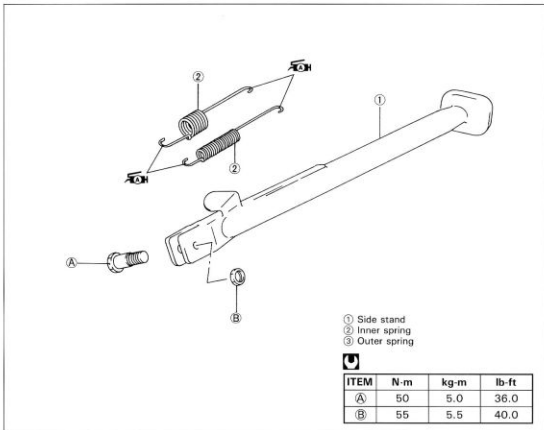

**SIDE STAND REMOVAL AND INSTALLATION**

- Support the motorcycle with jack or wooden block.
- Remove the original side stand by removing mounting nut and bolt.

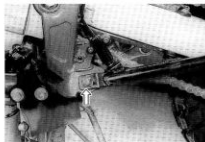

- Apply SUZUKI SUPER GREASE "A" to the side stand pivot portion and spring hooks.

 **99000-25030: SUZUKI SUPER GREASE "A"**

- Install the optional shorter side stand (silver-colored) and springs correctly as shown in the illustration.

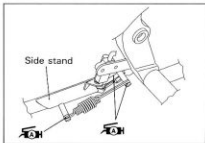

- Tighten the side stand mounting bolt and nut to the specified torque.

 Bolt: 50 N·m (5.0 kg-m, 36.0 lb-ft)  
Nut: 55 N·m (5.5 kg-m, 40.0 lb-ft)

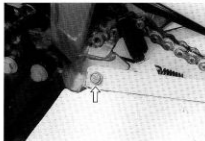

 **WARNING**

A new, shorter, silver-colored optional side stand must be installed for safe parking.

**NOTE:**

Make sure that the side stand switch operation after installing the side stand.

**WARNING LABEL**

- Attach the warning label (optional part) to the swingarm as shown in the illustration.

**NOTE:**

Select the appropriate language label for your country.

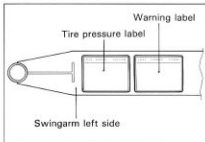

# ELECTRICAL SYSTEM

## CONTENTS

<b>CAUTIONS IN SERVICING</b> .....	6- 1
<b>LOCATION OF ELECTRICAL COMPONENTS</b> .....	6- 3
<b>CHARGING SYSTEM</b> .....	6- 4
<b>DESCRIPTION</b> .....	6- 4
<b>TROUBLESHOOTING</b> .....	6- 5
<b>INSPECTION</b> .....	6- 6
<b>STARTER SYSTEM AND SIDE-STAND/IGNITION INTERLOCK SYSTEM</b> .....	6- 9
<b>STARTER SYSTEM DESCRIPTION</b> .....	6- 9
<b>SIDE-STAND/IGNITION INTERLOCK SYSTEM DESCRIPTION</b> .....	6- 9
<b>TROUBLESHOOTING</b> .....	6-11
<b>STARTER MOTOR REMOVAL AND DISASSEMBLY</b> .....	6-12
<b>STARTER MOTOR INSPECTION</b> .....	6-12
<b>STARTER MOTOR REASSEMBLY</b> .....	6-13
<b>STARTER RELAY INSPECTION</b> .....	6-14
<b>SIDE-STAND/IGNITION INTERLOCK SYSTEM INSPECTION</b> .....	6-15
<b>IGNITION SYSTEM</b> .....	6-17
<b>DESCRIPTION</b> .....	6-17
<b>TROUBLESHOOTING</b> .....	6-18
<b>INSPECTION</b> .....	6-19
<b>SPEEDOMETER AND PILOT INDICATOR</b> .....	6-22
<b>REMOVAL AND DISASSEMBLY</b> .....	6-22
<b>INSPECTION</b> .....	6-22
<b>LAMPS</b> .....	6-24
<b>HEADLIGHT</b> .....	6-24
<b>TAIL/BRAKE LIGHT, TURN SIGNAL LIGHT AND LICENSE PLATE LIGHT</b> .....	6-25
<b>TURN SIGNAL RELAY</b> .....	6-26
<b>SWITCHES</b> .....	6-26
<b>BATTERY</b> .....	6-27
<b>SPECIFICATIONS</b> .....	6-27
<b>INITIAL CHARGING</b> .....	6-27
<b>SERVICING</b> .....	6-28
<b>RECHARGING OPERATION</b> .....	6-29

## CAUTIONS IN SERVICING

### CONNECTOR

- When connecting a connector, be sure to push it in until a click is felt.
- Inspect the connector for corrosion, contamination and breakage in its cover.

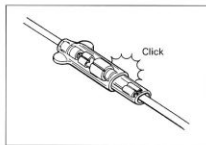

### COUPLER

- With a lock type coupler, be sure to release the lock before disconnecting it and push it in fully till the lock works when connecting it.
- When disconnecting the coupler, be sure to hold the coupler itself and do not pull the lead wires.
- Inspect each terminal on the coupler for being loose or bent.
- Inspect each terminal for corrosion and contamination.

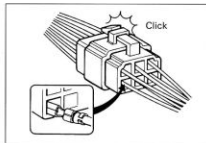

### CLAMP

- Clamp the wire harness at such positions as indicated in "WIRE HARNESS ROUTING" (Refer to pages 7-12 and 13.).
- Bend the clamp properly so that the wire harness is clamped securely.
- In clamping the wire harness, use care not to allow it to hang down.
- Do not use wire or any other substitute for the band type clamp.

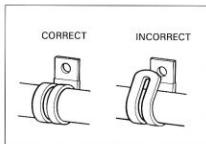

### FUSE

- When a fuse blows, always investigate the cause, correct it and then replace the fuse.
- Do not use a fuse of a different capacity.
- Do not use wire or any other substitute for the fuse.

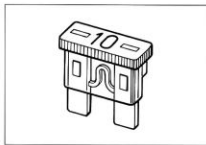

### SEMI-CONDUCTOR EQUIPPED PART

- Be careful not to drop the part with a semi-conductor built in such as a CDI unit and regulator/rectifier.
- When inspecting these parts, follow inspection instruction strictly. Neglecting proper procedure may cause damage to these parts.

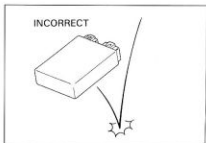

## BATTERY

- The MF battery used in this vehicle does not require maintenance as inspection of electrolyte level and replenishment of water.
- No hydrogen gas is produced during normal charging of the battery, but such gas may be produced when it is overcharged. Therefore, do not bring fire near the battery while it is being charged.
- Note that the charging system for the MF battery is different from that of an ordinary battery. Do not replace with an ordinary battery.

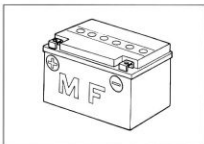

## CONNECTING BATTERY

- When disconnecting terminals from the battery for disassembly or servicing, be sure to disconnect the negative (⊖) terminal first.
- When connecting terminals to the battery, be sure to connect the positive (⊕) terminal first.
- If the terminal is found corroded, remove the battery, pour warm water over it and clean with a wire brush.
- Upon completion of connection, apply grease lightly.
- Put a cover over the positive (⊕) terminal.

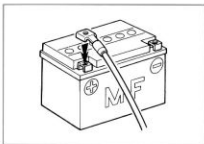
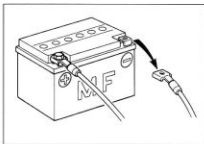

## WIRING PROCEDURE

- Route the wire harness properly according to "WIRE HARNESS ROUTING" (Refer to pages 7-12 and 13.).

## USING POCKET TESTER

- Be sure to use positive (⊕) and negative (⊖) probes of the tester properly. Their false use may cause damage in the tester.
- If the voltage and current values are not known, start measuring in the higher range.
- Before measuring the resistance and after changing the resistance range, always perform 0 Ω adjustment.
- Taking a measurement where voltage is applied in the resistance range may cause damage in the tester. When measuring resistance, check to make sure that no voltage is applied there.
- After using the tester, turn the switch to the OFF position.

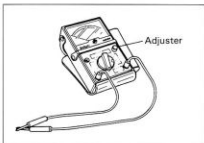

## LOCATION OF ELECTRICAL COMPONENTS

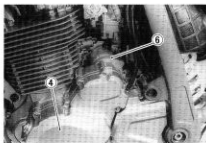
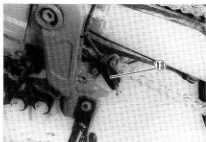
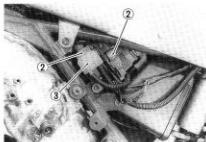
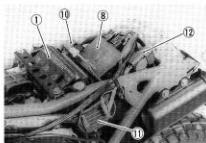

- ① Battery
- ② Fuse
- ③ Starter relay
- ④ Generator
- ⑤ Ignition coil
- ⑥ Starter motor
- ⑦ Horn
- ⑧ CDI unit
- ⑨ Diode
- ⑩ Turn signal relay
- ⑪ Regulator/rectifier
- ⑫ Side-stand/ignition interlock relay
- ⑬ Side-stand switch

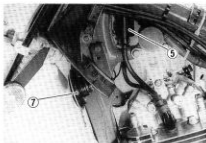



## CHARGING SYSTEM

### DESCRIPTION

The circuit of the charging system is indicated in the figure, which is composed of an AC generator, regulator/rectifier unit and battery.

The AC current generated from AC generator is converted by rectifier and is turned into DC current, then it charges the battery.

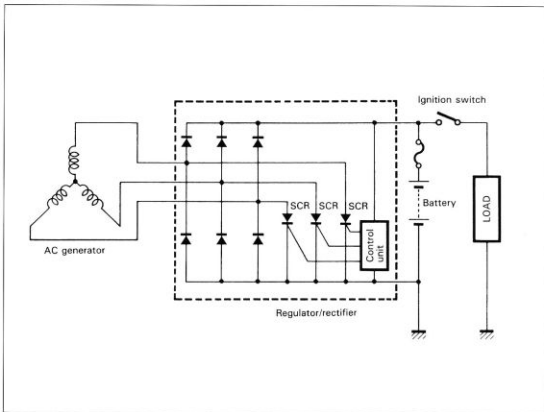

## TROUBLESHOOTING

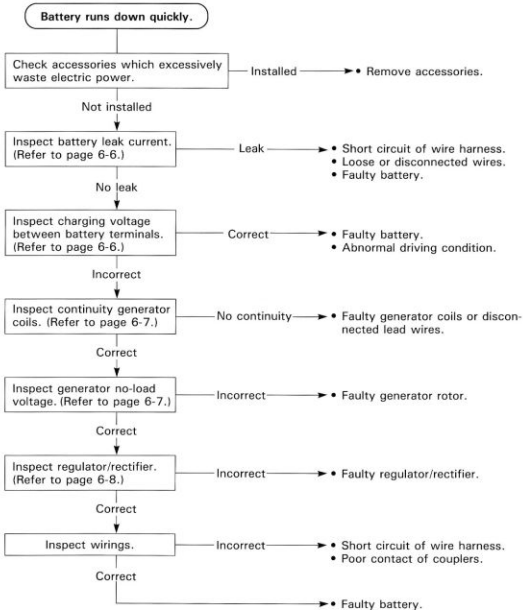
**Others**

Battery overcharge

- Faulty regulator/rectifier
- Faulty battery
- Poor contact of generator lead wire coupler

## INSPECTION

### BATTERY LEAK CURRENT INSPECTION

- Remove the frame covers and seat.
- Remove the battery holder plate ①.
- Turn the ignition switch to the OFF position.
- Disconnect the battery  $\ominus$  lead wire.

Note that leakage is indicated if the needle swings even a little when the milliampere meter of the pocket tester is connected between a  $\ominus$  terminal and the lead wire of the battery as shown.

 09900-25002: Pocket tester

#### CAUTION

- Because the leak current might be large, turn the tester to high range first when connecting an ammeter.
- Do not turn the ignition switch to the ON position when measuring current.

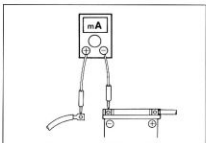

When leakage is found, look for the part where the needle does not swing through the couplers and connectors are removed one by one.

### CHARGING OUTPUT INSPECTION

- Remove the frame covers and seat.
- Remove the battery holder plate.
- Start the engine and keep it running at 5 000 r/min. with lighting switch turned ON and dimmer switch turned HI position.

Measure the DC voltage between the battery terminals  $\oplus$  and  $\ominus$  with a pocket tester. If the tester reads under the specified value, inspect the generator coil and regulator/rectifier.

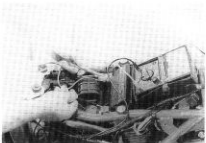

#### CAUTION

If the pocket tester is set to read current or resistance and a voltage is applied across the test probes, damage will result. Therefore, it is important that the tester knob on the pocket tester be set the proper position before making any measurements.

#### NOTE:

When making this test, be sure that the battery is fully-charged condition.

 09900-25002: Pocket tester

 Tester knob indication: DC 25V

Charging output

Standard: 13.0–16.0 at 5 000 r/min.

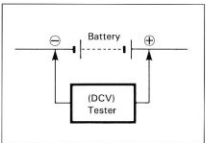

**GENERATOR COIL CONTINUITY INSPECTION**

- Remove the frame covers and seat.
- Disconnect the generator lead wire coupler ①.

Using a pocket tester, inspect the continuity between the three lead wires.

If there is no continuity, replace the generator coil with a new one.

 09900-25002: Pocket tester

 Tester knob indication: X 1  $\Omega$  range

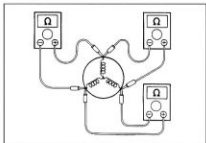
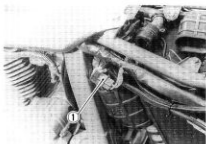
**GENERATOR NO-LOAD PERFORMANCE INSPECTION**

- Remove the frame covers and seat.
- Disconnect the generator lead wire coupler ①.
- Start the engine and keep it running at 5 000 r/min.

Using a pocket tester, measure the voltage between the three lead wires.

If the tester reads under the specified value, replace the generator coil with a new one.

 09900-25002: Pocket tester

 Tester knob indication: AC250V

Generator no-load performance:

More than 75V/5 000 r/min

(When engine is cold)

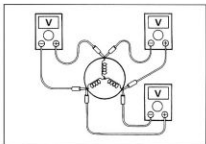
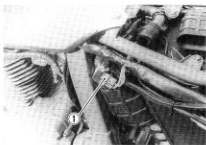

**REGULATOR/RECTIFIER INSPECTION**

- Remove the right frame cover.
- Disconnect the regulator/rectifier coupler ①.

Using a pocket tester (x 1k $\Omega$  range), measure the resistance between the terminals in the following table.

If resistance is incorrect, replace the regulator/rectifier.

 **09900-25002: Pocket tester**

 **Tester knob indication: X 1k $\Omega$  range**

Unit: k $\Omega$

① Probe of tester to:	⊕ Probe of tester to:				
	⊕	⊖	Y <sub>1</sub>	Y <sub>2</sub>	Y <sub>3</sub>
⊕					
⊖	1-20		1-10	1-10	1-10
Y <sub>1</sub>	1-10	$\infty$		$\infty$	$\infty$
Y <sub>2</sub>	1-10	$\infty$	$\infty$		$\infty$
Y <sub>3</sub>	1-10	$\infty$	$\infty$	$\infty$	

$\infty$ : Infinity

**NOTE:**

As diodes, thyristors are used inside this regulator/rectifier, the resistance values will differ when an ohmmeter other than the SUZUKI pocket tester is used.

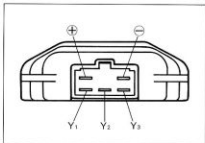
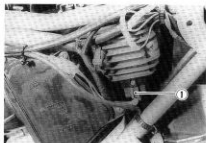

## STARTER SYSTEM AND SIDE-STAND/IGNITION INTERLOCK SYSTEM

### STARTER SYSTEM DESCRIPTION

The starter system is shown in the diagram below: namely, the starter motor, starter relay, side-stand relay, side-stand switch, neutral switch, clutch lever position switch, starter switch, engine stop switch, IG switch and battery.

Depressing the starter switch (on the right handlebars switch box) energizes the relay, causing the contact points to close which connects the starter motor to the battery. The motor draws about 70 amperes to start the engine.

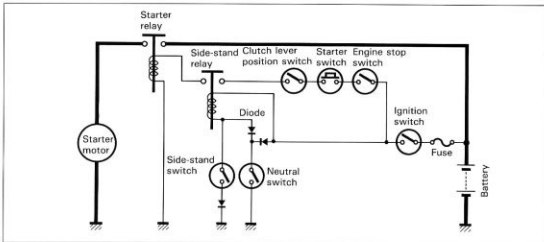

### SIDE-STAND/IGNITION INTERLOCK SYSTEM DESCRIPTION

This side-stand/ignition interlock system is to prevent starting the motorcycle with the side-stand left down. The system is operated by an electric circuit provided between the battery and ignition coil.

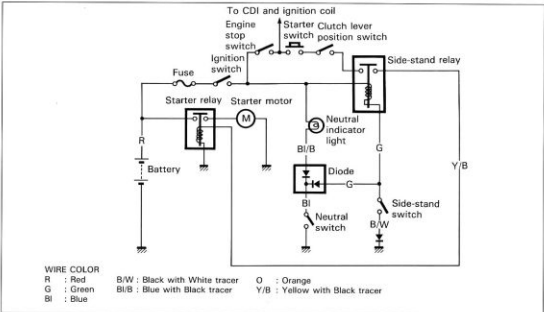

The circuit consists of relay, lamp, diode and switches and decides to live the ignition coil depending on the position of the TRANSMISSION and SIDE-STAND with the neutral and side-stand switches working mutually.

The ignition coil lives only in two situations as follows.

1. Transmission: "NEUTRAL (ON)" Side-stand: "DOWN (OFF)"

The current flow (A) turns "ON" the relay and the ignition coil lives even the side-stand is kept down. This is or warming up the engine.

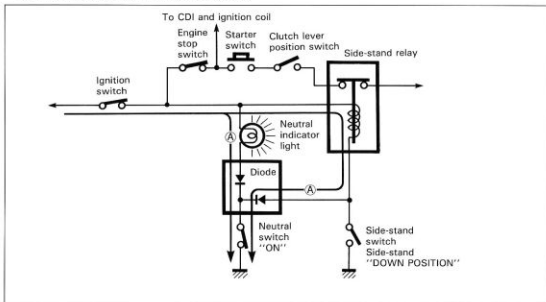

2. Side-stand: "UP-RIGHT (ON)"

The current flow (B) turns "ON" the relay and the ignition coil lives. The engine can be easily started at any transmission position.

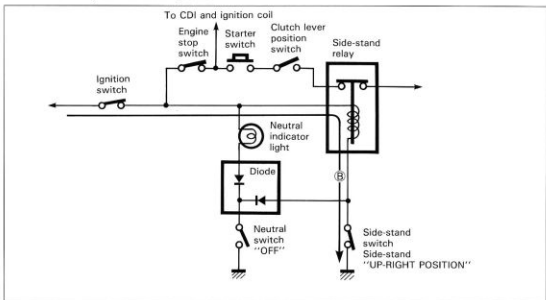

## TROUBLESHOOTING

Starter motor will not run.

The transmission is in neutral. Turn on the ignition switch with the engine stop switch in "RUN" position. Check whether to hear the click noise from the starter relay when the starter button is pushed.

Clicks

Check whether to run the starter motor when connect the starter motor terminal to the battery  $\oplus$  terminal directly. (Do not use thin wire, because a large amount of current flows.)

Run

Not run

- Faulty starter motor

- Faulty starter relay
- Loosen or disconnected starter motor lead wire

No click

Measure the starter relay voltage at the starter relay connectors (between Y/G  $\oplus$  and B/W  $\ominus$ ) when the starter button is pushed.

Not voltage

- Faulty ignition switch
- Faulty engine stop switch
- Faulty neutral switch
- Faulty diode
- Faulty side-stand relay
- Faulty starter button
- Faulty clutch lever position switch
- Poor contact of connector
- Open circuit in wiring harness

Voltage measured

Check the starter relay. (Refer to page 6-14.)

Incorrect

- Faulty starter relay

Correct

- Poor contact of the starter relay

Starter motor runs when the transmission is in neutral, but does not run with the transmission in any position except neutral, with the side-stand up position.

Check the side-stand switch. (Refer to page 6-16.)

Incorrect

- Faulty side-stand switch

Correct

- Open circuit in wiring harness
- Poor contact of connector

Others

Engine does not turn though starter motor runs.

- Faulty starter clutch



## STARTER MOTOR REMOVAL AND DISASSEMBLY

- Remove the exhaust pipe.
- Remove the cam drive chain tensioner.
- Disconnect the starter motor lead wire and remove the starter motor by removing the mounting bolts.  
(Refer to page 3-11.)

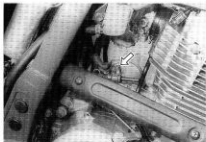

- Disassemble the starter motor as shown in the illustration.

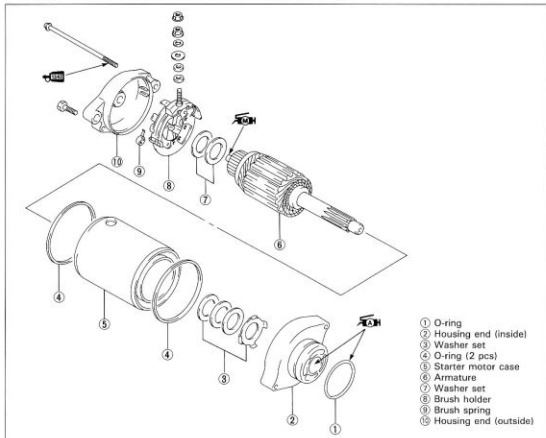

## STARTER MOTOR INSPECTION

### CARBON BRUSH

Inspect the brushed for abnormal wear, crack or smoothness in the brush holder.

If the brush has failed, replace the brush sub assy.

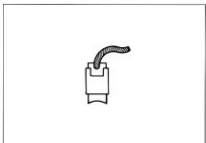

**COMMUTATOR**

Inspect the commutator for discoloration, abnormal wear or undercut (A).

If the commutator is abnormally worn, replace the armature. When surface is discolored, polish it with # 400 sand paper and clean it with dry cloth.

If there is no undercut, scrape out the insulator (1) with saw blade.

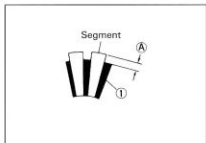
**ARMATURE COIL INSPECTION**

Check for continuity between each segment.

Check for continuity between each segment and the armature shaft.

If there is no continuity between the segments or there is continuity between the segments and shaft, replace the armature with a new one.

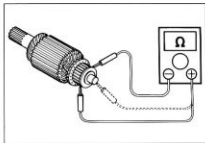
**OIL SEAL INSPECTION**

Check the seal lip for damage or leakage.

If any damage is found, replace the bracket.

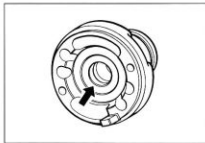
**STARTER MOTOR REASSEMBLY**

Reassemble the starter motor in the reverse order of disassembly. Pay attention to the following points:

**CAUTION**

Replace the O-rings with new ones to prevent oil leakage and moisture.

- Apply SUZUKI SUPER GREASE "A" to the lip of the oil seal.

 99000-25030: SUZUKI SUPER GREASE "A"

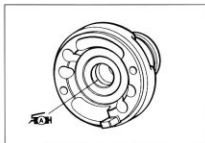

- Apply a small quantity of MOLY PASTE to the armature shaft.

 99000-25140: SUZUKI MOLY PASTE

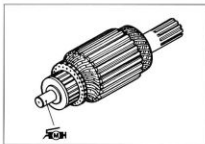

- Apply a small quantity of THREAD LOCK "1342" to the starter motor housing bolts.

 99000-32050: THREAD LOCK "1342"



## STARTER RELAY INSPECTION

- Remove the right frame cover.
- Remove the starter relay cover.
- Disconnect the starter motor lead wire and battery lead wire at the starter relay.
- Disconnect the lead wire coupler from the starter relay.



Apply 12 volts to ① and ② terminals, inspect the continuity between the terminals, positive and negative. If the starter relay is in sound condition, continuity is found.

 09900-25002: Pocket tester

 Tester knob indication: X 1Ω range

### CAUTION

Do not apply a battery voltage more than 5 seconds to the starter relay as it may overheat and cause damage to the relay coil.

Check the coil for "open", "ground" and ohmic resistance. The coil is in good condition if the resistance is as follows.

 09900-25002: Pocket tester

 Tester knob indication: X 1Ω range

Starter relay resistance

Standard: 3–5Ω

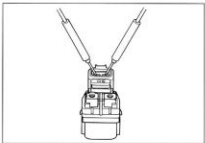
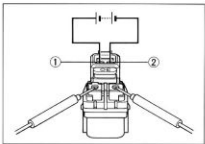

### STARTER RELAY CIRCUIT DIAGRAM

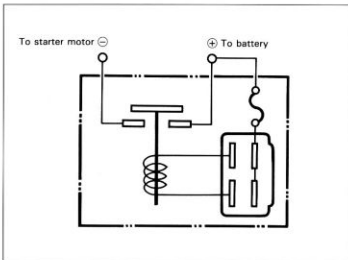

### SIDE-STAND/IGNITION INTERLOCK SYSTEM INSPECTION

If the interlock system does not operate properly, check each component. If any abnormality is found, replace the component with a new one.

 09900-25002: Pocket tester

### DIODE

The diode is located under the seat.

The diode can pass current only in one direction.

Check the continuity between ① and ②. If one way continuity the diode is in good condition.

Also check the continuity between ② and ③ as required.

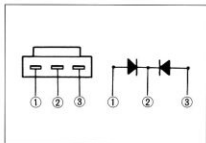

**NEUTRAL SWITCH**

The neutral lead wire coupler is located behind the left frame cover.

- Remove the frame covers and seat.
- Disconnect the neutral switch lead and check the continuity between Blue and Ground with the transmission in "NEUTRAL".

**SIDE-STAND SWITCH**

	Green (⊖ Probe)	Black/White (⊕ Probe)
ON (UP-right position)	○ — ○	○ — ○
OFF (Down position)		

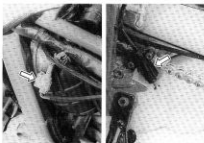
**SIDE-STAND/IGNITION INTERLOCK RELAY**

The side-stand/ignition interlock relay is located under the seat.

- Remove the frame covers and seat.



First, check the insulation between ① and ② terminals with pocket tester. Then apply 12 volts to ③ and ④ terminals, ⊕ to ③ and ⊖ to ④, and check the continuity between ① and ②.

If there is no continuity, replace it with a new one.

 09900-25002: Pocket tester

 Tester knob indication: X 1Ω range

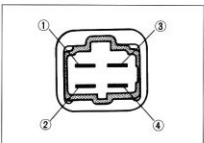
**CLUTCH LEVER POSITION SWITCH**

	Yellow/Green	Yellow/Green
ON (Squeeze)	○ — ○	○ — ○
OFF		



## IGNITION SYSTEM

### DESCRIPTION

In the capacitor discharged ignition system, the electrical energy generated by the magneto charges the capacitor. This energy is released in a single surge at the specified ignition timing point, and current flows through the primary side of the ignition coil. A high voltage current is induced in the secondary windings of the ignition coil resulting in strong spark between the spark plug gap.

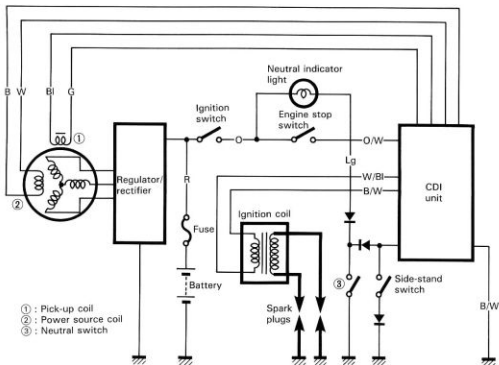

## TROUBLESHOOTING

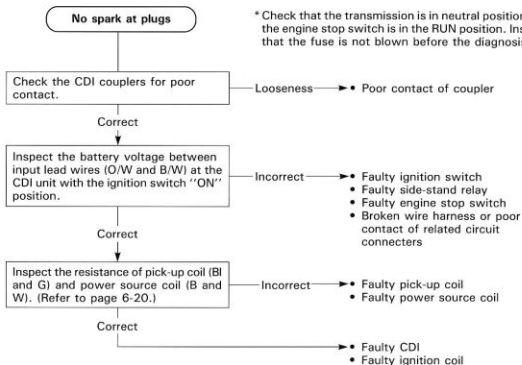

\* If only one spark plug does not spark, it is defective or high-tension cord is disconnected because one ignition coil furnishes two spark plugs.

## INSPECTION

### IGNITION COIL (Checking with Electro Tester)

- Remove the fuel tank.
- Remove the ignition coil.

#### NOTE:

Make sure that the three-needle sparking distance of electro tester is set at 8 mm (0.3 in).

With the tester and jumper wire, test the ignition coil for sparking performance in accordance with the following two steps.

STEP ① : Connect the jumper wire to the spark plug cap and ignition coil ground.

STEP ② : Switch over the jumper wire to the other plug cap and ground.

If no sparking or orange color sparking occurs in the above conditions, it may be caused by defective coil.

 09900-28107: Electro tester

Spark performance: Over 8 mm (0.3 in)

#### **WARNING**

Do not touch the wire clips to prevent an electric shock when testing.

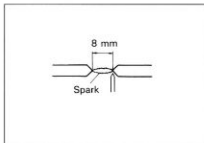
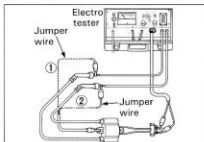

### IGNITION COIL (Checking with Pocket Tester)

A SUZUKI pocket tester or an ohm meter may be used, instead of the electro tester. In either case, the ignition coil is to be checked for continuity in both primary and secondary windings. Exact ohmic readings are not necessary, but, if the windings are in sound condition, their continuity will be noted with these approximate ohmic values.

 09900-25002: Pocket tester

#### Ignition coil resistance

Primary: 0.07—0.12  $\Omega$  (+ Black lead—⊖ Black/white lead)

 Tester knob indication: X 1  $\Omega$  range

Secondary: 23—25 k $\Omega$  (Plug cap—Plug cap)

 Tester knob indication: X 1 k $\Omega$  range

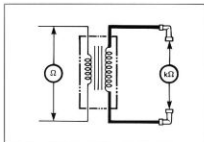
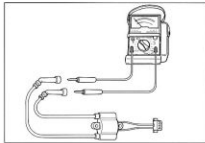



**POWER SOURCE COIL AND PICK-UP COIL**

- Remove the frame covers and seat.
- Disconnect the lead wire coupler ① from the CDI unit. Measure each coil resistance between lead wires. If the resistance is infinity or less than the specifications, the power source coil and pick-up coil must be replaced.

**09900-25002: Pocket tester**

Power source coil resistance: 0.1—0.2Ω  
(Black—White)

Tester knob indication: X 1Ω range

Pick-up coil resistance: 170—256Ω  
(Blue—Green)

Tester knob indication: X 100Ω range

**CDI UNIT**

- Remove the frame covers and seat.
- Disconnect the lead wire couplers ② from the CDI unit. Measure the CDI unit resistance between the terminals. If the resistance is incorrect, the CDI unit must be replaced.

**NOTE:**

As capacitor, thyristors, diodes, etc. are used inside this CDI unit, the resistance values will differ when an ohmmeter other than SUZUKI pocket tester is used.

**09900-25002: Pocket tester**

Tester knob indication: X 1 kΩ range

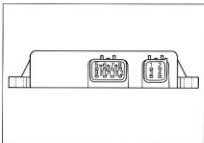

Unit: kΩ

		⊕ Probe of tester											
		1	2	3	4	5	6	7	8	9	10	11	12
① Probe of tester	1	0	6-26	12-50	2.4-10	2.6-12	0	0	50-400	200-∞	35-400	1.2-5	
	2	0	5.5-24	12-50	2.4-10	2.6-12	0	0	50-400	200-∞	35-500	1.2-5	
	3	5.5-24	5.5-24	20-90	8-35	8-35	5.5-24	5.5-24	50-400	200-∞	45-500	7-28	
	4	15-70	15-70	26-150	16-70	17-80	5.5-70	5.5-70	80-500	200-∞	80-∞	14-60	
	5	2.2-9.5	2.2-9.5	8-35	11-70	3-13	2.2-9.5	2.2-9.5	50-400	200-∞	40-500	1.4-6	
	6	2.8-12	2.8-12	8-35	17-70	3-13	2.8-12	2.8-12	50-400	200-∞	40-500	1.8-8	
	7	0	0	6-26	12-50	2.2-9.5	2.6-11	0	0	50-400	200-∞	35-500	1.2-4.8
	8	0	0	6-26	12-50	2.2-9.5	2.6-11	0	0	50-400	200-∞	70-500	3.6-4.8
	9	1.8-7.5	1.8-7.5	10-45	24-200	5-22	6-24	1.8-7.5	1.8-7.5	200-∞	70-∞	3.6-11	
	10	11-50	11-50	22-100	35-400	17-70	17-70	11-50	12-50	80-1000	200-∞	14-60	
	11	∞	∞	∞	∞	∞	∞	∞	∞	∞	∞	∞	
	12	1.2-5	1.2-5	7-28	14-60	1.4-6	1.8-8	1.2-5	1.2-5	50-400	200-∞	35-500	

**NOTE:** When the capacitor is discharged state, the needle of tester swings first then return to a certain value.

∞ : Infinity

**SPARK PLUG**

- Remove the spark plugs.

 09930-10121: Spark plug socket wrench set

**Carbon Deposit**

Check to see the carbon deposit on the plug.

If the carbon is deposited, remove it with a spark plug cleaner machine or carefully using a tool with a pointed end.

**Spark Plug Gap**

Measure the plug gap with a thickness gauge if it is correct. If not, adjust it to the following gap.

 09900-20803: Thickness gauge

Standard: 0.7–0.8 mm (0.028–0.031 in)

**Electrode's Condition**

Check to see a worn or burnt condition of the electrode. If it is extremely worn or burnt, replace the plug. Also replace the plug if it has a broken insulator, damaged thread, etc.

**Heat Range**

NGK CR10E or NIPPONDENSO U31ESR-N should be used as the standard. However, the heat range of the spark plug should be selected to meet the requirements of speed, actual load, fuel and etc. Proper heat range would be indicated if all insulators were LIGHT BROWN in color. If they are blackened by carbon, they should be replaced with a hot type plug NGK CR9E or NIPPONDENSO U27ESR-N.

	Standard	Hot type
NGK	CR10E	CR9E
NIPPONDENSO	U31ESR-N	U27ESR-N

**⚠ CAUTION**

Confirm the thread size and reach when replacing the plug. If the reach is too short, carbon will be deposited on the screw portion of the plug hole and engine damage may result.

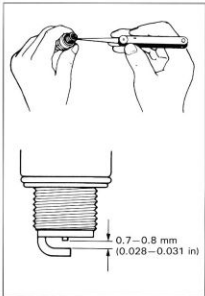

## SPEEDOMETER AND PILOT INDICATOR

### REMOVAL AND DISASSEMBLY

- Remove the speedometer and pilot indicator. (Refer to page 5-4.)
- Disassemble the speedometer and pilot indicator as follows.

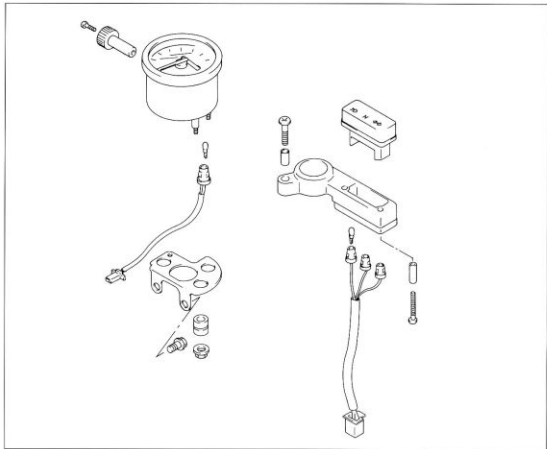

### INSPECTION

Using the pocket tester, check the continuity between lead wires in the diagram on next page.

If the continuity measured is incorrect, replace the respective parts.

 09900-25002: Pocket tester

 Tester knob indication: X 1Ω range

#### NOTE:

*When making this test, it is not necessary to remove the speedometer and pilot indicator.*

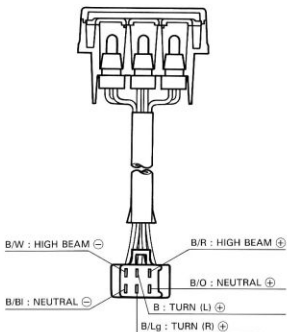
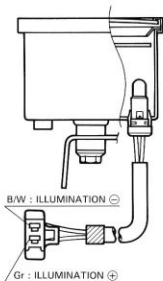

ITEM	⊕ Probe of tester to:	⊖ Probe of tester to:
ILLUMI	Gr	B/W
HIGH BEAM	B/R	B/W
NEUTRAL	B/O	B/Bl
TURN (L)	B	B/Lg
TURN (R)	B/Lg	B

B : Black  
 Gr : Gray  
 B/Bl : Black with Blue tracer  
 B/O : Black with Orange tracer  
 B/R : Black with Red tracer  
 B/Lg : Black with Light green tracer  
 B/W : Black with White tracer

## LAMPS HEADLIGHT

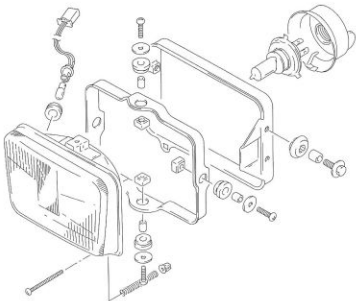

Headlight bulb: 12V 60/55W

Position light bulb: 12V 4W (Except E-03,24,28,33)

**NOTE:**

*Adjust the headlight, both vertical and horizontal, after reassembling.*

### BULB REPLACEMENT

- Remove the headlight. (Refer to page 5-21.)
- Disconnect the socket ① and remove the rubber cap ②.
- Remove the bulb ③ by unlocking the bulb holder spring ④.
- Reassemble the bulb in the reverse order of removal.

### ⚠ CAUTION

When replacing the headlight bulb, do not touch the glass. Grasp the new bulb with a clean cloth. If you touch the bulb with your bare hands, clean it with a cloth moistened with alcohol or soapy water to prevent early failure.

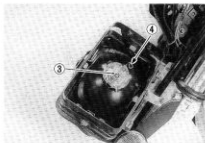
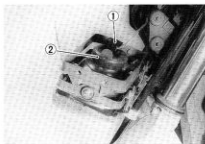

## TAIL/BRAKE LIGHT, TURN SIGNAL LIGHT AND LICENSE PLATE LIGHT

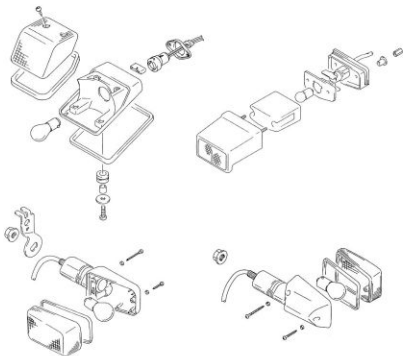

Tail/Brake light bulb: 12V 5/21W

Turn signal light bulb: 12V 21W

License plate light bulb: 12V 5W

#### BULB REPLACEMENT

- Remove each light lens.
- Push in on the bulb, turn it to the left, and pull it out.

#### CAUTION

Do not overtighten the lens fitting screws.

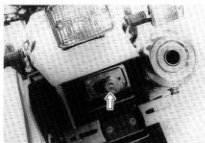
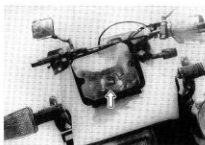

## TURN SIGNAL RELAY

The turn signal relay ① is located under the seat. If the turn signal light does not light, inspect the bulb or repair the circuit connection. If the bulb and circuit connection checked are correct, the turn signal relay may be faulty, replace it with a new one.

### NOTE:

Be sure that the battery used is in full-charged condition.



## SWITCHES

Inspect each switch for continuity with the pocket tester. If any abnormality is found, replace the respective switch assemblies with new ones.

 09900-25002: Pocket tester

 Tester knob indication: X 1Ω range

### IGNITION SWITCH

Position \ Color	R	O	O/Y	B/W	Gr	Br
OFF						
ON	○—○		○—○			○—○
LOCK						
P	○—○					○—○

### LIGHTING SWITCH

Position \ Color	O	Gr	Y/W
OFF			
•		○—○	
ON	○—○	○—○	

### DIMMER SWITCH

Position \ Color	Y/W	W	Y
HI	○—○		○—○
LO	○—○		

### TURN SIGNAL SWITCH

Position \ Color	Lg	Lbl	B
L		○—○	○—○
PUSH			
R	○—○		

### PASSING LIGHT SWITCH

Position \ Color	O/R	Y
•		
PUSH	○—○	

### ENGINE STOP SWITCH

Position \ Color	O	O/W
OFF		
RUN	○—○	

### STARTER BUTTON

Position \ Color	O/W	Y/G
•		
PUSH	○—○	

### HORN BUTTON

Position \ Color	B/Bl	B/W
•		
PUSH	○—○	○—○

### FRONT BRAKE SWITCH

Position \ Color	O	B
OFF		
ON	○—○	○—○

### REAR BRAKE SWITCH

Position \ Color	O	W/B
OFF		
ON	○—○	○—○

### WIRE COLOR

B : Black    Lbl: Light blue    R : Red  
 Br : Brown    Lg : Light green    Y : Yellow  
 Gr : Gray    O : Orange    W : White  
 B/Bl : Black with Blue tracer  
 B/W : Black with White tracer  
 O/Bl : Orange with Blue tracer  
 O/R : Orange with Red tracer  
 O/W : Orange with White tracer  
 O/Y : Orange with Yellow tracer  
 W/B : White with Black tracer  
 Y/G : Yellow with Green tracer  
 Y/W : Yellow with White tracer

## BATTERY

### SPECIFICATIONS

Type designation	YTX9-BS
Capacity	12V, 28.8 kC (8 Ah)/10HR
Standard electrolyte S.G.	1.320 at 20°C (68°F)

### INITIAL CHARGING

#### Filling electrolyte

- Remove the aluminum tape ① sealing the battery electrolyte filler holes.

- Remove the caps ② .

#### NOTE:

- After filling the electrolyte completely, use the removed cap ② as the sealed caps of battery-filler holes.
- Do not remove or pierce the sealed areas ③ of the electrolyte container.

- Insert the nozzles of the electrolyte container into the battery's electrolyte filler holes, holding the container firmly so that it does not fall. Take precaution not to allow any of the fluid to spill.

- Make sure air bubbles are coming up each electrolyte container, and leave in this position for about more than 20 minutes.

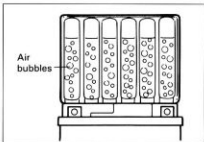
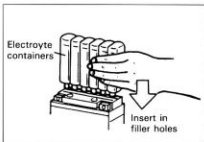
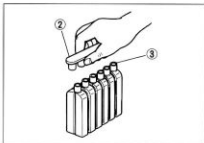
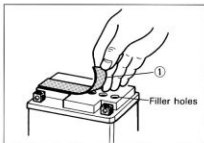
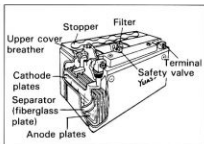



**NOTE:**

If no air bubbles are coming up from a filler port, tap the bottom of the two or three times.

Never remove the container from the battery.

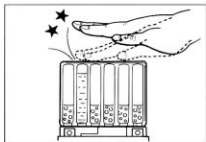

- After confirming that the electrolyte has entered the battery completely, remove the electrolyte containers from the battery. Wait for around 20 minutes.
- Insert the caps into the filler holes, pressing in firmly so that the top of the caps do not protrude above the upper surface of the battery's top cover.

**CAUTION**

- \* Never use anything except the specified battery.
- \* Once install the caps to the battery; do not remove the caps.

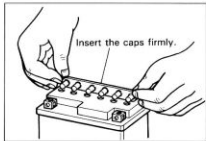

- Using SUZUKI pocket tester, measure the battery voltage. The tester should indicate more than 12.5–12.6V (DC) as shown in the Fig. If the battery voltage is lower than the specification, charge the battery with a battery charger. (Refer to the recharging operation.)

**NOTE:**

Initial charging for a new battery is recommended if two years have elapsed since the date of manufacture.

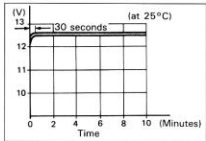
**SERVICING**

Visually inspect the surface of the battery container. If any signs of cracking or electrolyte leakage from the sides of the battery have occurred, replace the battery with a new one. If the battery terminals are found to be coated with rust or an acidic white powdery substance, then this can be cleaned away with sandpaper.

## RECHARGING OPERATION

- Using the pocket tester, check the battery voltage. If the voltage reading is less than the 12.0V (DC), recharge the battery with a battery charger.

### CAUTION

When recharging the battery, remove the battery from the motorcycle.

#### NOTE:

Do not remove the caps on the battery top while recharging.

Recharging time: 4A for one hour or 0.9A for 5 hours

### CAUTION

Be careful not to permit the charging current to exceed 4A at any time.

- After recharging, wait for more than 30 minutes and check the battery voltage with a pocket tester.
- If the battery voltage is less than the 12.5V, recharge the battery again.
- If battery voltage is still less than 12.5V, after recharging, replace the battery with a new one.
- When the motorcycle is not used for a long period, check the battery every 1 month to prevent the battery discharge.

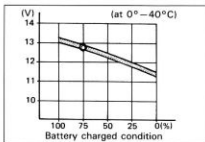
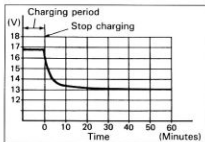

# SERVICING INFORMATION

## CONTENTS

<b>TROUBLESHOOTING</b> .....	<b>7- 1</b>
<b>WIRING DIAGRAM</b> .....	<b>7- 8</b>
<b>WIRE, CABLE AND HOSE ROUTING</b> .....	<b>7-11</b>
<b>WIRE ROUTING</b> .....	<b>7-12</b>
<b>CABLE ROUTING</b> .....	<b>7-15</b>
<b>CARBURETOR AND AIR CLEANER HOSE ROUTING</b> .....	<b>7-17</b>
<b>PAIR (AIR SUPPLY) SYSTEM HOSE ROUTING</b> .....	<b>7-18</b>
<b>FRONT BRAKE HOSE ROUTING</b> .....	<b>7-19</b>
<b>REAR BRAKE HOSE ROUTING</b> .....	<b>7-20</b>
<b>HEAT SHIELD ADHERING</b> .....	<b>7-21</b>
<b>SIDE STAND SPRING SET-UP</b> .....	<b>7-21</b>
<b>SPECIAL TOOLS</b> .....	<b>7-22</b>
<b>TIGHTENING TORQUE</b> .....	<b>7-25</b>
<b>SERVICE DATA</b> .....	<b>7-28</b>

## TROUBLESHOOTING

## ENGINE

Complaint	Symptom and possible causes	Remedy
<p><b>Engine will not start, or is hard to start.</b></p>	<p><b>Compression too low</b></p> <ol style="list-style-type: none"> <li>1. Out of adjustment valve clearance.</li> <li>2. Worn valve guides or poor seating of valves.</li> <li>3. Mistiming valves.</li> <li>4. Excessively worn piston rings.</li> <li>5. Worn-down cylinder bores.</li> <li>6. Too slowly starter motor cranks.</li> <li>7. Poor seating of spark plugs.</li> </ol> <p><b>Plugs not sparking</b></p> <ol style="list-style-type: none"> <li>1. Fouled spark plugs.</li> <li>2. Wet spark plugs.</li> <li>3. Defective ignition coil.</li> <li>4. Open or short in high-tension cords.</li> <li>5. Defective generator or CDI unit.</li> <li>6. Defective side stand switch or side stand relay.</li> </ol> <p><b>No fuel reaching the carburetor</b></p> <ol style="list-style-type: none"> <li>1. Clogged fuel tank cap.</li> <li>2. Clogged or defective fuel valve.</li> <li>3. Defective carburetor needle valve.</li> <li>4. Clogged fuel hose or vacuum hose.</li> <li>5. Clogged fuel filter.</li> </ol>	<p>Adjust. Repair or replace. Adjust. Replace. Replace or rebore. See electrical section. Retighten.</p> <p>Clean. Clean and dry. Replace. Replace. Replace. Replace.</p> <p>Clean or replace. Clean or replace. Replace. Clean or replace. Clean or replace.</p>
<p><b>Engine stalls easily.</b></p>	<ol style="list-style-type: none"> <li>1. Fouled spark plugs.</li> <li>2. Defective signal generator or CDI unit.</li> <li>3. Clogged fuel hose.</li> <li>4. Clogged jets in carburetor.</li> <li>5. Out of adjustment valve clearance.</li> </ol>	<p>Clean. Replace. Clean. Clean. Adjust.</p>
<p><b>Noisy engine.</b></p>	<p><b>Excessive valve chatter</b></p> <ol style="list-style-type: none"> <li>1. Too large valve clearance.</li> <li>2. Weakened or broken valve springs.</li> <li>3. Worn down rocker arm or rocker arm shaft.</li> <li>4. Worn and burnt camshaft journal.</li> </ol> <p><b>Noise seems to come from piston</b></p> <ol style="list-style-type: none"> <li>1. Worn down piston or cylinder.</li> <li>2. Fouled with carbon combustion chamber.</li> <li>3. Worn piston pins or piston pin bore.</li> <li>4. Worn piston rings or ring grooves.</li> </ol> <p><b>Noise seems to come from timing chain</b></p> <ol style="list-style-type: none"> <li>1. Stretched chain.</li> <li>2. Worn sprocket.</li> <li>3. Not working tension adjuster.</li> </ol> <p><b>Noise seems to come from clutch</b></p> <ol style="list-style-type: none"> <li>1. Worn splines of countershaft or hub.</li> <li>2. Worn teeth of clutch plates.</li> <li>3. Distorted clutch plates, driven and drive.</li> <li>4. Worn clutch release bearing.</li> <li>5. Weakened clutch dampers.</li> </ol>	<p>Adjust. Replace. Replace. Replace.</p> <p>Replace. Clean. Replace. Replace.</p> <p>Replace. Replace. Repair or replace.</p> <p>Replace. Replace. Replace. Replace. Replace the primary driven gear.</p>

Complaint	Symptom and possible causes	Remedy
<b>Noisy engine.</b>	<b>Noise seems to come from crankshaft</b> 1. Due to wear rattling bearings. 2. Worn and burnt big-end bearings. 3. Too large thrust clearance.  <b>Noise seems to come from transmission</b> 1. Worn or rubbing gears. 2. Badly worn splines. 3. Worn or rubbing primary gears. 4. Badly worn bearings.	Replace. Replace. Replace conrod.  Replace. Replace. Replace. Replace.
<b>Slipping clutch.</b>	1. Out of adjustment or loss of play clutch control. 2. Weakened clutch springs. 3. Worn or distorted pressure plate. 4. Distorted clutch plates, driven and drive.	Adjust. Replace. Replace. Replace.
<b>Dragging clutch.</b>	1. Clutch control out of adjustment or loss of play. 2. Some clutch springs weakened while others are not. 3. Distorted pressure plate or clutch plates.	Adjust Replace. Replace.
<b>Transmission will not shift.</b>	1. Broken gearshift cam. 2. Distorted gearshift forks. 3. Worn gearshift pawl.	Replace. Replace. Replace.
<b>Transmission will not shift back.</b>	1. Broken return spring on shift shaft. 2. Rubbing or sticky shift shaft. 3. Distorted or worn gearshift forks.	Replace. Repair or replace. Replace.
<b>Transmission jumps out of gear.</b>	1. Worn shifting gears on driveshaft or countershaft. 2. Distorted or worn gearshift forks. 3. Weakened stopper spring on gearshift cam. 4. Worn gearshift pawl.	Replace. Replace. Replace. Replace.
<b>Engine idles poorly.</b>	1. Out of adjustment valve clearance. 2. Poor seating of valves. 3. Defective valve guides. 4. Worn rocker arms or arm shafts. 5. Too wide spark plug gaps. 6. Defective ignition coil. 7. Defective generator or CDI unit. 8. Out of adjustment in carburetor float-chamber fuel level. 9. Clogged jets.	Adjust. Replace or repair. Replace. Replace. Adjust or replace. Replace. Replace. Adjust.  Clean.

## 7-3 SERVICING INFORMATION

Complaint	Symptom and possible causes	Remedy
<b>Engine runs poorly in high speed range.</b>	<ol style="list-style-type: none"> <li>1. Weakened valve springs.</li> <li>2. Worn camshafts.</li> <li>3. Valve timing out of adjustment.</li> <li>4. Too narrow spark plug gaps.</li> <li>5. Ignition not advanced sufficiently due to poorly working timing advance circuit.</li> <li>6. Defective ignition coil.</li> <li>7. Defective generator or CDI unit.</li> <li>8. Too low float-chamber fuel level.</li> <li>9. Clogged air cleaner element.</li> <li>10. Clogged fuel hose, resulting in inadequate fuel supply to carburetor.</li> </ol>	<p>Replace. Replace. Adjust. Adjust. Replace CDI unit.</p> <p>Replace. Replace. Adjust. Clean. Clean and prime.</p>
<b>Dirty or heavy exhaust smoke.</b>	<ol style="list-style-type: none"> <li>1. Too much engine oil in the engine.</li> <li>2. Worn piston rings or cylinder.</li> <li>3. Worn valve guides.</li> <li>4. Scuffed cylinder wall.</li> <li>5. Worn valves stems.</li> <li>6. Defective stem seal.</li> <li>7. Worn oil ring side rails.</li> </ol>	<p>Check with inspection window drain out excess oil. Replace. Replace. Replace. Replace. Replace. Replace.</p>
<b>Engine lacks power.</b>	<ol style="list-style-type: none"> <li>1. Loss of valve clearance.</li> <li>2. Weakened valve springs.</li> <li>3. Out of adjustment valve timing.</li> <li>4. Worn piston rings or cylinder.</li> <li>5. Poor seating of valves.</li> <li>6. Fouled spark plug.</li> <li>7. Incorrect spark plug.</li> <li>8. Clogged jets in carburetor.</li> <li>9. Out of adjustment float-chamber fuel level.</li> <li>10. Clogged air cleaner element.</li> <li>11. Sucking air from intake pipe.</li> <li>12. Too much engine oil.</li> <li>13. Defective generator, CDI unit or ignition coil.</li> </ol>	<p>Adjust. Replace. Adjust. Replace. Repair. Clean or replace. Adjust or replace. Clean. Adjust. Clean. Retighten or replace. Drain out excess oil. Replace.</p>
<b>Engine overheats.</b>	<ol style="list-style-type: none"> <li>1. Heavy carbon deposit on piston crown.</li> <li>2. Not enough oil in the engine.</li> <li>3. Defective oil pump or clogged oil circuit.</li> <li>4. Too low in float chamber fuel level.</li> <li>5. Sucking air from intake pipes.</li> <li>6. Use incorrect engine oil.</li> <li>7. Oil cooler.</li> </ol>	<p>Clean. Add oil. Replace or clean. Adjust. Retighten or replace. Change. Clean.</p>

## CARBURETOR

Complaint	Symptom and possible causes	Remedy
Trouble with starting.	<ol style="list-style-type: none"> <li>1. Clogged starter jet.</li> <li>2. Clogged starter pipe.</li> <li>3. Air leaking from a joint between starter body and carburetor.</li> <li>4. Air leaking from carburetor's joint or vacuum gauge joint.</li> <li>5. Not operation properly starter plunger.</li> </ol>	<p>Clean. Clean.</p> <p>Check starter body and carburetor for tightness, adjust and replace gasket.</p> <p>Check and adjust.</p> <p>Check and adjust.</p>
Idling or low-speed trouble.	<ol style="list-style-type: none"> <li>1. Clogged or loose pilot jet, pilot air jet.</li> <li>2. Air leaking from carburetor's joint, vacuum hose joint, or starter.</li> <li>3. Clogged pilot outlet or bypass.</li> <li>4. Not fully closed starter plunger.</li> </ol>	<p>Check and clean. Check and adjust.</p> <p>Check and clean. Check and adjust.</p>
Medium or high speed trouble.	<ol style="list-style-type: none"> <li>1. Clogged main jet or main air jet.</li> <li>2. Clogged needle jet.</li> <li>3. Not operating properly throttle valve.</li> <li>4. Clogged fuel filter.</li> </ol>	<p>Check and clean. Check and clean.</p> <p>Check throttle valve for operation. Check and clean.</p>
Overflow and fuel level fluctuations.	<ol style="list-style-type: none"> <li>1. Worn or damaged needle valve.</li> <li>2. Broken spring in needle valve.</li> <li>3. Not working properly float.</li> <li>4. Foreign matter has adhered to needle valve.</li> <li>5. Too high or low fuel level.</li> </ol>	<p>Replace. Replace.</p> <p>Check and adjust. Clean.</p> <p>Adjust float height.</p>

## CHASSIS

Complaint	Symptom and possible causes	Remedy
Heavy steering.	<ol style="list-style-type: none"> <li>1. Overtightened steering stem nut.</li> <li>2. Broken bearing in steering stem.</li> <li>3. Distorted steering stem.</li> <li>4. Not enough pressure in tires.</li> </ol>	<p>Adjust. Replace. Replace. Adjust.</p>
Wobbly handlebars.	<ol style="list-style-type: none"> <li>1. Loss of balance between right and left front forks.</li> <li>2. Distorted front fork.</li> <li>3. Distorted front axle or crooked tire.</li> </ol>	<p>Replace. Repair or replace. Replace.</p>
Wobbly front wheel.	<ol style="list-style-type: none"> <li>1. Distorted wheel rim.</li> <li>2. Worn front wheel bearings.</li> <li>3. Defective or incorrect tire.</li> <li>4. Loose axle or axle holder nuts.</li> <li>5. Incorrect front fork oil level.</li> </ol>	<p>Replace. Replace. Replace. Retighten. Adjust.</p>
Front suspension too soft.	<ol style="list-style-type: none"> <li>1. Weakened springs.</li> <li>2. Not enough fork oil.</li> </ol>	<p>Replace. Replenish.</p>
Front suspension too stiff.	<ol style="list-style-type: none"> <li>1. Too viscous fork oil.</li> <li>2. Too much fork oil.</li> </ol>	<p>Replace. Drain excess oil.</p>
Noisy front suspension.	<ol style="list-style-type: none"> <li>1. Not enough fork oil.</li> <li>2. Loose bolts and nuts on suspension.</li> </ol>	<p>Replenish. Retighten.</p>

**7-5 SERVICING INFORMATION**

Complaint	Symptom and possible causes	Remedy
<b>Wobbly rear wheel.</b>	<ol style="list-style-type: none"><li>1. Distorted wheel rim.</li><li>2. Worn rear wheel bearings or swingarm bearings.</li><li>3. Defective or incorrect tire.</li><li>4. Worn swingarm and rear suspension related bearings.</li><li>5. Loose nuts or bolts on rear suspensions.</li></ol>	Replace. Replace. Replace. Replace. Retighten.
<b>Rear suspension too soft.</b>	<ol style="list-style-type: none"><li>1. Weakened shock absorber spring.</li><li>2. Improperly set rear suspension adjuster.</li><li>3. Leakage oil of shock absorber.</li></ol>	Replace. Adjust. Replace.
<b>Rear suspension too stiff.</b>	<ol style="list-style-type: none"><li>1. Improperly set rear suspension adjuster.</li><li>2. Bent shock absorber shaft.</li><li>3. Bent swingarm.</li><li>4. Worn swingarm and rear suspension related bearings.</li></ol>	Adjust. Replace. Replace. Replace.
<b>Noisy rear suspension.</b>	<ol style="list-style-type: none"><li>1. Loose nuts or bolts on rear suspension.</li><li>2. Worn swingarm and rear suspension related bearings.</li></ol>	Retighten. Replace.

**BRAKES**

Complaint	Symptom and possible causes	Remedy
<b>Insufficient brake power.</b>	<ol style="list-style-type: none"><li>1. Leakage of brake fluid from hydraulic system.</li><li>2. Worn pads.</li><li>3. Oil adhesion of engaging surface of pads.</li><li>4. Worn disc.</li><li>5. Air in hydraulic system.</li></ol>	Repair or replace. Replace. Clean disc and pads. Replace. Bleed air.
<b>Brake squeaking.</b>	<ol style="list-style-type: none"><li>1. Carbon adhesion on pad surface.</li><li>2. Tilted pad.</li><li>3. Damaged wheel bearing.</li><li>4. Loosen front-wheel axle or rear-wheel axle.</li><li>5. Worn pads.</li><li>6. Foreign material in brake fluid.</li><li>7. Clogged return port of master cylinder.</li></ol>	Repair surface with sandpaper. Modify pad fitting or replace. Replace. Tighten to specified torque. Replace. Replace brake fluid. Disassemble and clean master cylinder.
<b>Excessive brake lever or pedal stroke.</b>	<ol style="list-style-type: none"><li>1. Air in hydraulic system.</li><li>2. Insufficient brake fluid.</li><li>3. Improper quality of brake fluid.</li></ol>	Bleed air. Replenish fluid to specified level; bleed air. Replace with correct fluid.
<b>Leakage of brake fluid.</b>	<ol style="list-style-type: none"><li>1. Insufficient tightening of connection joints.</li><li>2. Cracked hose.</li><li>3. Worn piston and/or cup.</li></ol>	Tighten to specified torque. Replace. Replace piston and/or cup.



## ELECTRICAL

Complaint	Symptom and possible causes	Remedy
No sparking or poor sparking.	<ol style="list-style-type: none"> <li>1. Defective ignition coil.</li> <li>2. Defective spark plugs.</li> <li>3. Defective generator or CDI unit.</li> </ol>	Replace. Replace. Replace.
Spark plug soon become fouled with carbon.	<ol style="list-style-type: none"> <li>1. Mixture too rich.</li> <li>2. Idling speed set too high.</li> <li>3. Incorrect gasoline.</li> <li>4. Dirty element in air cleaner.</li> <li>5. Too cold spark plugs.</li> </ol>	Adjust carburetor. Adjust carburetor. Change. Clean. Replace with hot type plugs.
Spark plugs become fouled too soon.	<ol style="list-style-type: none"> <li>1. Worn piston rings.</li> <li>2. Worn piston or cylinder.</li> <li>3. Excessive clearance of valve stems in valve guides.</li> <li>4. Worn stem oil seal.</li> </ol>	Replace. Replace. Replace. Replace.
Spark plug electrodes overheat or burn.	<ol style="list-style-type: none"> <li>1. Too hot spark plugs.</li> <li>2. Overheated the engine.</li> <li>3. Loose spark plugs.</li> <li>4. Too lean mixture.</li> </ol>	Replace with cold type plugs. Tune up. Retighten. Adjust carburetor.
Generator does not charge.	<ol style="list-style-type: none"> <li>1. Open or short lead wires, or loose lead connections.</li> <li>2. Shorted, grounded or open generator coils.</li> <li>3. Shorted or punctured regulator/rectifier.</li> </ol>	Repair or replace or retighten. Replace. Replace.
Generator does charge, but charging rate is below the specification.	<ol style="list-style-type: none"> <li>1. Lead wires tend to get shorted or open-circuited or loosely connected at terminals.</li> <li>2. Grounded or open-circuited stator coils or generator.</li> <li>3. Defective regulator/rectifier.</li> <li>4. Defective cell plates in the battery.</li> </ol>	Repair or retighten. Replace. Replace. Replace the battery.
Generator overcharges.	<ol style="list-style-type: none"> <li>1. Internal short-circuit in the battery.</li> <li>2. Damaged or defective regulator/rectifier.</li> <li>3. Poorly grounded regulator/rectifier.</li> </ol>	Replace the battery. Replace. Clean and tighten ground connection.
Unstable charging.	<ol style="list-style-type: none"> <li>1. Lead wire insulation frayed due to vibration, resulting in intermittent shorting.</li> <li>2. Internally shorted generator.</li> <li>3. Defective regulator/rectifier.</li> </ol>	Repair or replace. Replace. Replace.
Starter button is not effective.	<ol style="list-style-type: none"> <li>1. Run down battery.</li> <li>2. Defective switch contacts.</li> <li>3. Not seating properly brushes on commutator in starter motor.</li> <li>4. Defective starter relay/starter interlock switch.</li> </ol>	Repair or replace. Replace. Repair or replace. Replace.

**BATTERY**

Complaint	Symptom and possible causes	Remedy
"Sulfation", acidic white powdery substance or spots on surfaces of cell plates.	<ol style="list-style-type: none"> <li>1. Cracked battery case.</li> <li>2. Battery has been left in a run-down condition for a long time.</li> </ol>	<p>Replace the battery. Replace the battery.</p>
Battery runs down quickly.	<ol style="list-style-type: none"> <li>1. Not correct the charging system.</li> <li>2. Cell plates have lost much of their active material as a result of overcharging.</li> <li>3. A short-circuit condition exists within the battery.</li> <li>4. Too low battery voltage.</li> <li>5. Too old battery.</li> </ol>	<p>Check the generator, regulator/rectifier and circuit connections and make necessary adjustments to obtain specified charging operation. Replace the battery, and correct the charging system. Replace the battery. Recharge the battery fully. Replace the battery.</p>
Battery "sulfation".	<ol style="list-style-type: none"> <li>1. Too low or too high charging rate. (When not in use batteries should be checked at least once a month to avoid sulfation.)</li> <li>2. Left unused the battery for too long in cold climate.</li> </ol>	<p>Replace the battery.  Replace the battery, if badly sulfated.</p>
Battery discharges too rapidly.	Dirty container top and sides.	Clean.

# WIRING DIAGRAM FOR CANADA AND U.S.A.

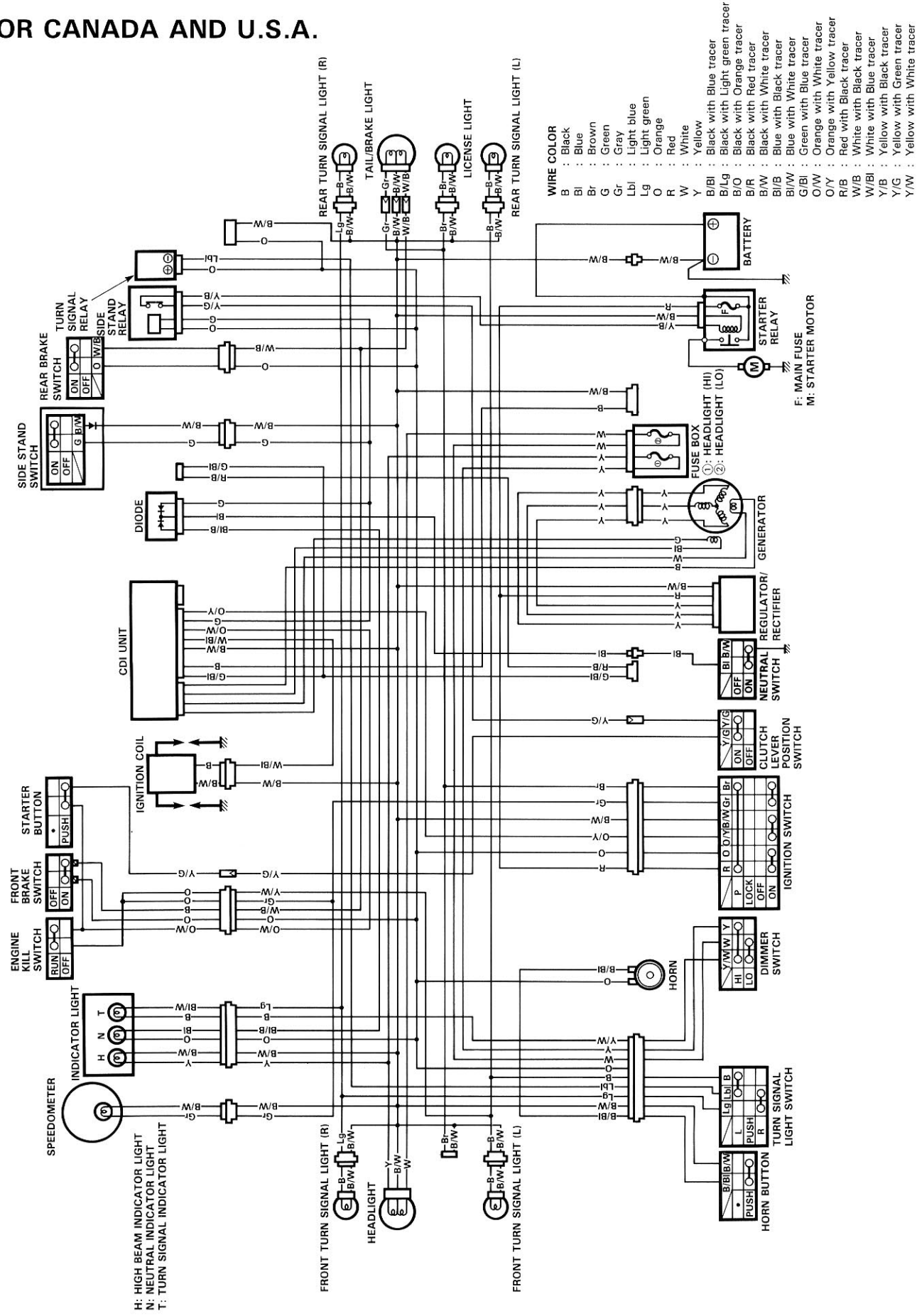

For Australia

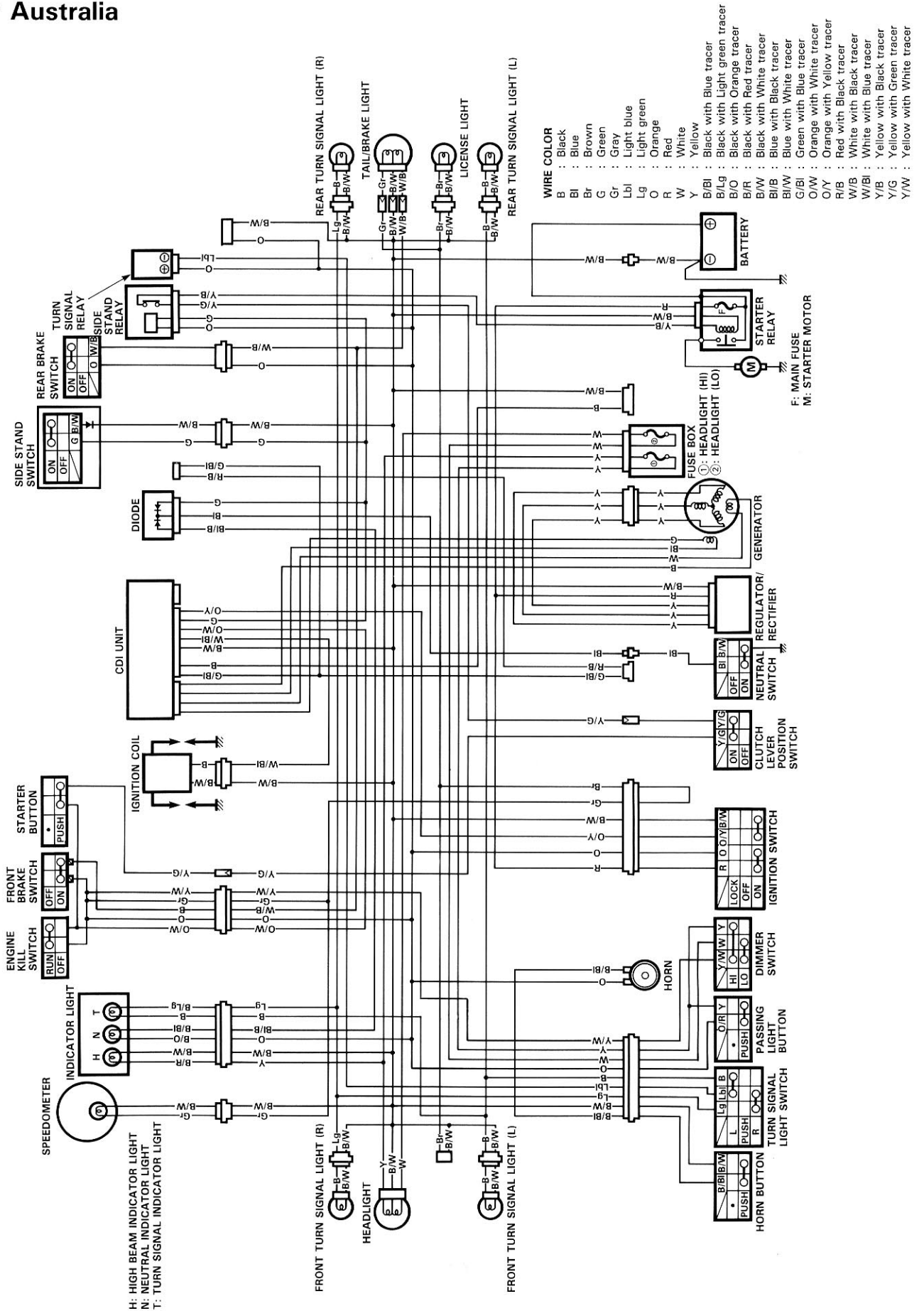

# For Austria and Switzerland

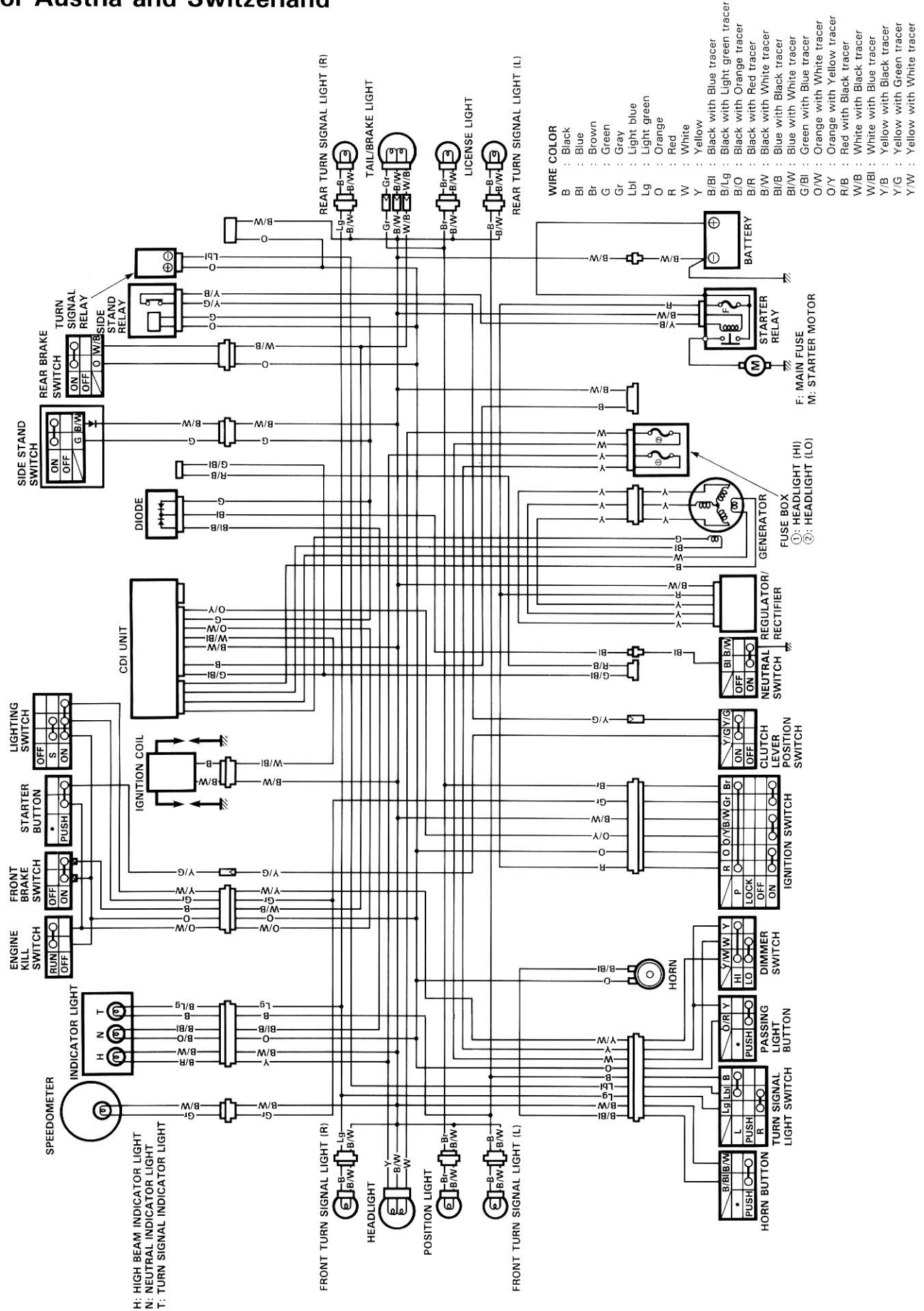

For the others

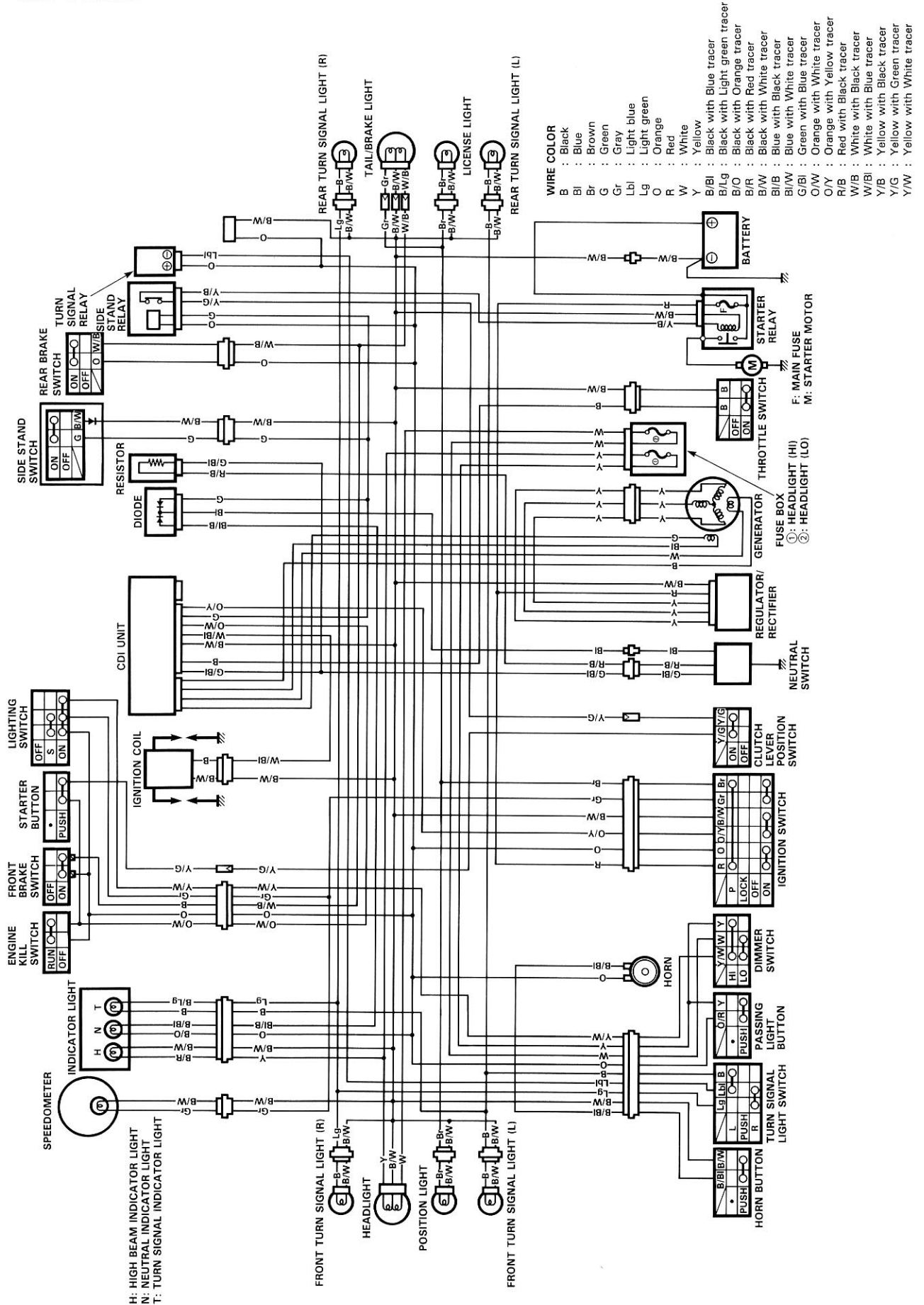

## WIRE, CABLE AND HOSE ROUTING

### WIRE ROUTING

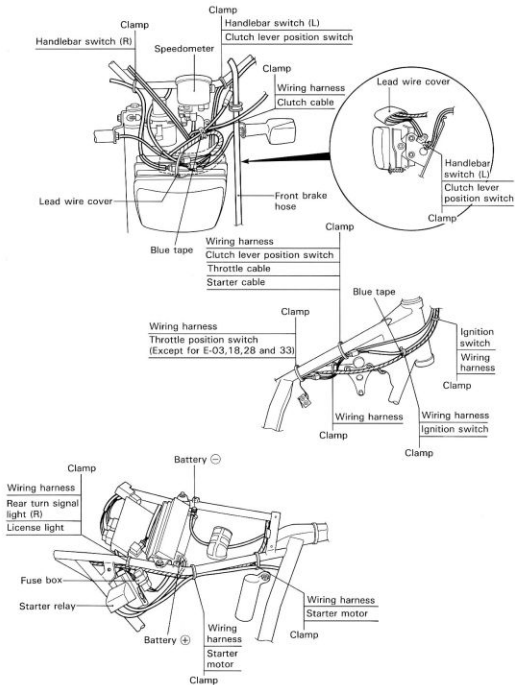

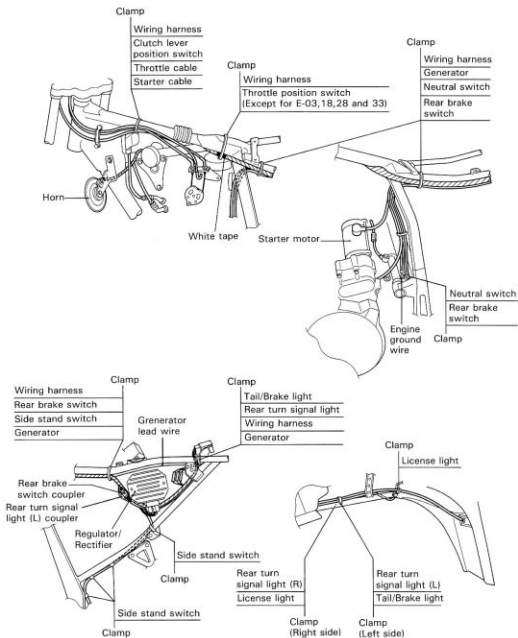



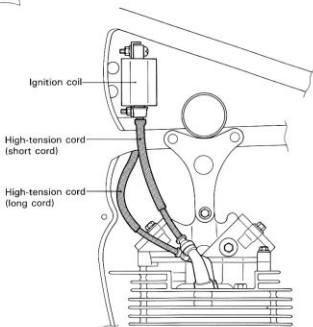
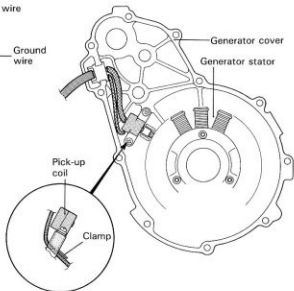
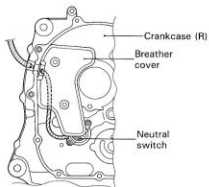
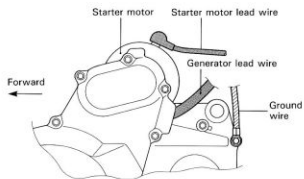

## CABLE ROUTING

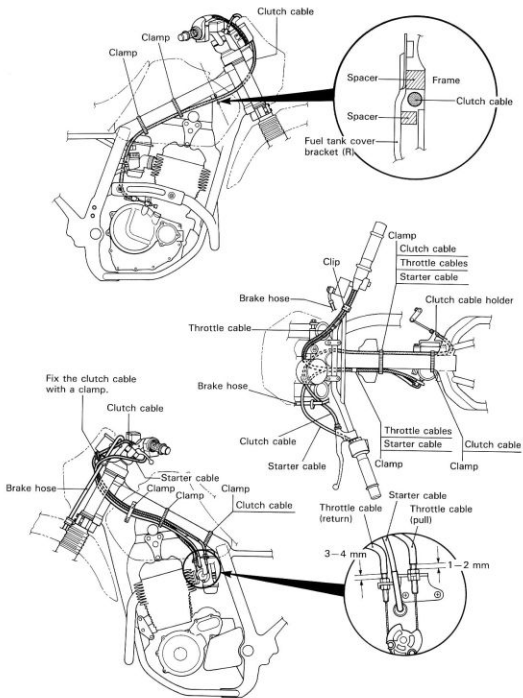

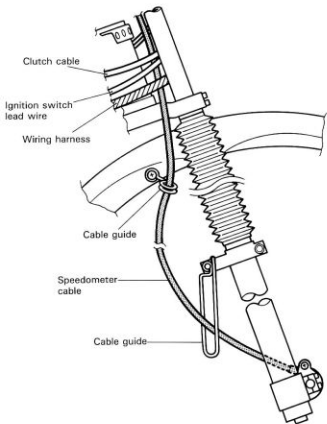

## CARBURETOR AND AIR CLEANER HOSE ROUTING

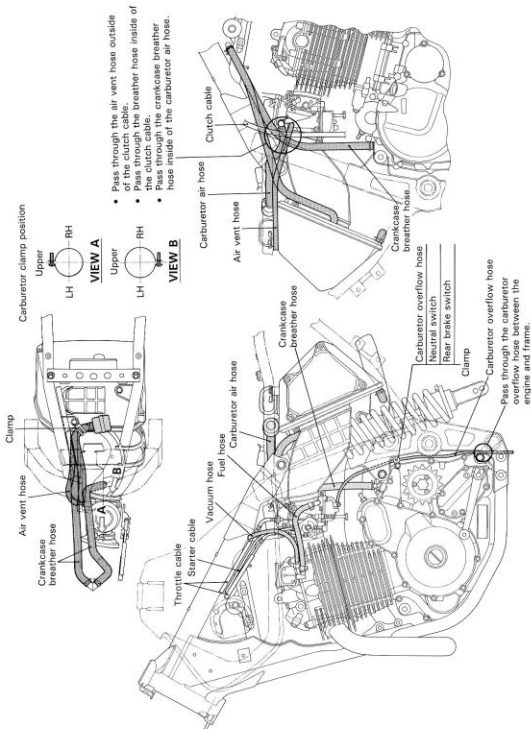

## PAIR (AIR SUPPLY) SYSTEM HOSE ROUTING (For Austria and Switzerland)

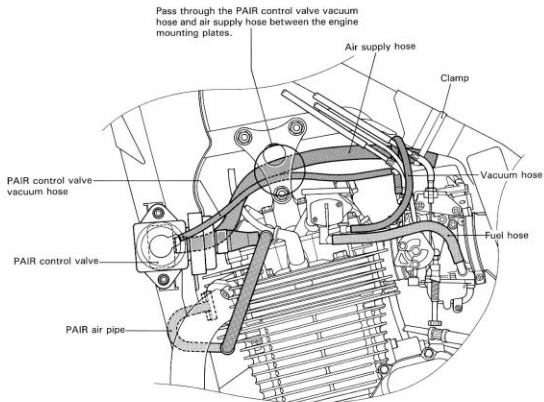

## FRONT BRAKE HOSE ROUTING

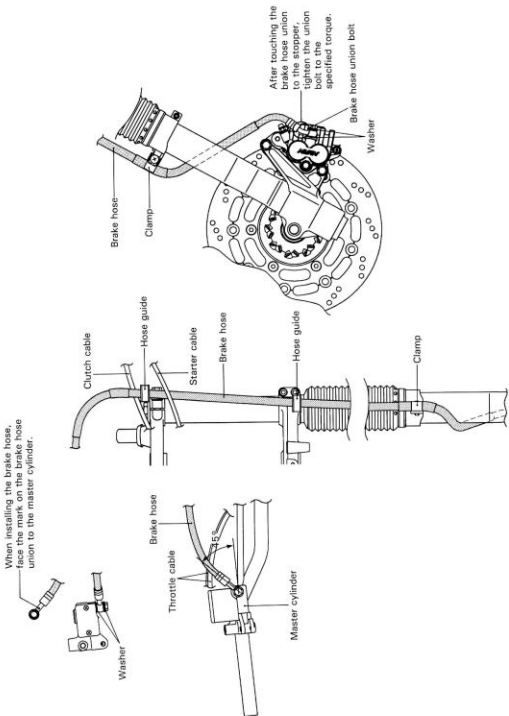

## REAR BRAKE HOSE ROUTING

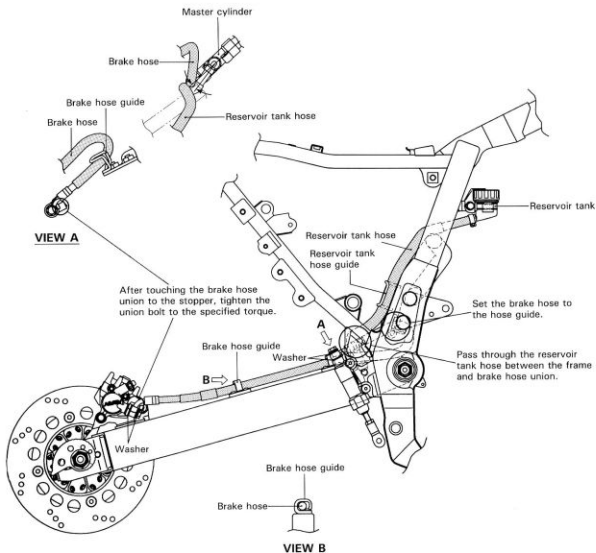

## HEAT SHIELD ADHERING

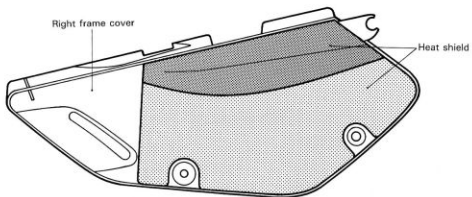



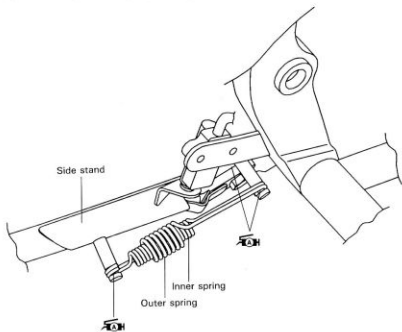

























## SIDE STAND SPRING SET-UP







## SPECIAL TOOLS

				
09900-00401 "L" type hexagon wrench set	09900-00410 Hexagon bit wrench set	09900-06107 Snap ring pliers	09900-06108 Snap ring pliers	09900-09003 Impact driver set
				
09900-20102 Vernier calipers	09900-20202 Micrometer (25–50 mm)	09900-20204 Micrometer (75–100 mm)	09900-20205 Micrometer (0–25 mm)	09900-20508 Cylinder bore gauge set 09900-20513 Gauge rod 94 mm
				
09900-20605 Dial calipers	09900-20606 Dial gauge (1/100)	09900-20701 Magnetic stand	09900-20803 Thickness gauge	09900-21304 V-block (100 mm)
				
09900-22301 Plastigauge	09900-25002 Pocket tester	09900-28106 Electro tester	09910-20116 Conrod holder	09910-32812 Crankshaft installer
				
09910-32830 Crankshaft installer attachment	09910-32860 Crankshaft installer attachment	09910-33210 Attachment	09910-60611 Universal clamp wrench	09913-10720 Compression gauge attachment
				
09913-50121 Oil seal remover	09913-60910 Bearing/gear puller	09913-75810 Bearing installer	09913-75830 Bearing installer	09915-64510 Compression gauge

				
09915-74510 Oil pressure gauge	09916-14510 Valve spring compressor	09916-14910 Valve spring compressor attachment	09916-20610 Valve seat cutter head 15° (N-121)	09916-24210 Valve seat cutter head 45° (N-615)
				
09916-24900	09916-34550 5.5 mm reamer	09916-34580 10.8 mm reamer	09916-44910 Valve guide remover	09916-84511 Tweezers
				
09917-23711 Ring nut socket wrench	09920-13120 Crankcase separator/ crankshaft remover	09920-53740 Clutch sleeve hub holder	09923-73210 Bearing remover	09923-74510 Bearing remover
				
09924-84510 Bearing installer set	09924-84521 Bearing installer set	09925-18010 Steering bearing installer	09930-11920 Torx bit JT40H	09930-11940 Torx bit holder
				
09930-30102 Sliding shaft	09930-33720 Generator rotor remover	09930-73110 Starter torque limiter holder	09930-73120 Starter torque limiter socket	09940-14911 Steering nut socket wrench
				
09940-14960 Steering nut wrench socket	09940-34520 'T' handle	09940-34592 Attachment G	09940-52860 Front fork oil seal installer	09941-34513 Steering race and swingarm bearing installer

 <p>09941-50111 Wheel bearing remover</p>	 <p>09941-54911 Bearing outer race remover</p>	 <p>09941-74910 Steering bearing remover</p>	 <p>09943-74111 Front fork oil level gauge</p>
---	---	---	---

## TIGHTENING TORQUE

## ENGINE

ITEM	N-m	kg-m	lb-ft
Cylinder head cover bolt	10	1.0	7.0
Camshaft sprocket bolt	15	1.5	11.0
Cylinder head bolt	38	3.8	27.5
Cylinder head nut	25	2.5	18.0
Cylinder base nut	10	1.0	7.0
Cam drive chain tensioner fitting bolt	13	1.3	9.5
Generator rotor bolt	160	16.0	115.5
Can drive chain adjuster mounting bolt	10	1.0	7.0
Spark plug	11	1.1	8.0
Crankcase bolt	11	1.1	8.0
T.D.C. plug	23	2.3	16.5
Oil gallery	23	2.3	16.5
Oil nozzle bolt	10	1.0	7.0
Generator cover plug	15	1.5	11.0
Starter clutch bolt	25	2.5	18.0
Primary drive gear nut	100	10.0	72.5
Clutch spring mounting bolt	10	1.0	7.0
Clutch sleeve hub nut	50	5.0	36.0
Gearshift arm stopper	19	1.9	13.5
Engine oil drain plug	23	2.3	16.5
Engine sprocket bolt	6	0.6	4.5
Engine mounting bolt 8 mm Diam.	40	4.0	29.0
Engine mounting bolt 10 mm Diam.	65	6.5	47.0
Engine mounting bracket bolt (Upper and Front)	40	4.0	29.0
(Rear)	23	2.3	16.5
Exhaust pipe bolt	26	2.6	19.0
Muffler mounting bolt	26	2.6	19.0
Crankshaft bearing ring nut	80	8.0	58.0
Engine oil pipe union bolt (Cylinder head)	23	2.3	16.5
(Crankcase)	20	2.0	14.5
Engine oil cooler hose bolt	10	1.0	7.0
Cam drive chain adjuster cap bolt	6	0.6	4.5

## CHASSIS

ITEM	N-m	kg-m	lb-ft
Front axle	65	6.5	47.0
Front axle holder nut	10	1.0	7.0
Front fork damper rod bolt	30	3.0	21.5
Front fork lower clamp bolt	26	2.6	19.0
Front fork upper clamp bolt	29	2.9	21.0
Front fork cap bolt	23	2.3	16.5
Steering stem head nut	90	9.0	65.0
Handlebar clamp bolt	23	2.3	16.5
Handlebar holder nut	25	2.5	18.0
Front brake master cylinder mounting bolt	10	1.0	7.0
Front brake caliper mounting bolt	26	2.6	19.0
Brake caliper axle bolt (Front & Rear)	23	2.3	16.5
	13	1.3	9.5
Brake hose union bolt (Front & Rear)	23	2.3	16.5
Brake pad mounting pin (Front & Rear)	18	1.8	13.0
Front brake pad mounting pin plug	2.5	0.25	1.8
Brake air bleeder valve (Front & Rear)	8	0.8	6.0
Brake disc mounting bolt (Front & Rear)	23	2.3	16.5
Swingarm pivot nut	77	7.7	55.5
Front footrest bolt	39	3.9	28.0
Chain roller mounting bolt (Upper & Lower)	40	4.0	29.0
Rear brake master cylinder mounting bolt	10	1.0	7.0
Rear brake rod lock nut	18	1.8	13.0
Rear shock absorber bolt (Upper & Lower)	55	5.5	40.0
Rear cushion lever nut (Front)	80	8.0	58.0
Rear cushion lever nut (Center)	100	10.0	72.5
Rear cushion rod nut	100	10.0	72.5
Rear axle nut	For Canada and U.S.A.	100	72.5
	For the others	110	79.5
Rear sprocket mounting nut	27	2.7	19.5
Spoke nipple (Front & Rear)	4.5	0.45	3.0

**TIGHTENING TORQUE CHART**

For other bolts and nuts listed previously, refer to this chart:

Bolt Diameter Ⓐ (mm)	Conventional or "4" marked bolt			"7" marked bolt		
	N·m	kg·m	lb·ft	N·m	kg·m	lb·ft
4	1.5	0.15	1.0	2.3	0.23	1.5
5	3	0.3	2.0	4.5	0.45	3.0
6	5.5	0.55	4.0	10	1.0	7.0
8	13	1.3	9.5	23	2.3	16.5
10	29	2.9	21.0	50	5.0	36.0
12	45	4.5	32.5	85	8.5	61.5
14	65	6.5	47.0	135	13.5	97.5
16	105	10.5	76.0	210	21.0	152.0
18	160	16.0	115.5	240	24.0	173.5



Conventional bolt



"4" marked bolt



"7" marked bolt

## SERVICE DATA

## VALVE + GUIDE

Unit: mm (in)

ITEM		STANDARD	LIMIT
Valve diam.	IN.	33 (1.3)	—
	EX.	28 (1.1)	—
Valve clearance (when engine is cold)	IN.	0.08–0.13 (0.003–0.005)	—
	EX.	0.17–0.22 (0.0067–0.0087)	—
Valve guide to valve stem clearance	IN.	0.010–0.037 (0.0004–0.0015)	—
	EX.	0.030–0.057 (0.0012–0.0022)	—
Valve stem deflection	IN. & EX.	—	0.35 (0.014)
Valve guide I.D.	IN. & EX.	5.500–5.512 (0.2165–0.2170)	—
Valve stem O.D.	IN.	5.475–5.490 (0.2156–0.2161)	—
	EX.	5.455–5.470 (0.2148–0.2154)	—
Valve stem runout	IN. & EX.	—	0.05 (0.002)
Valve head thickness	IN. & EX.	—	0.5 (0.02)
Valve stem end length	IN. & EX.	—	2.7 (0.11)
Valve seat width	IN. & EX.	0.9–1.1 (0.035–0.043)	—
Valve head radial runout	IN. & EX.	—	0.03 (0.001)
Valve spring free length (IN. & EX.)	INNER	—	34.4 (1.35)
	OUTER	—	38.1 (1.50)
Valve spring tension (IN. & EX.)	INNER	5.9–6.7 kg (13.0–14.8 lbs) at length 27.5 mm (1.1 in)	—
	OUTER	13.8–15.8 kg (30.4–34.8 lbs) at length 31.0 mm (1.2 in)	—

## CAMSHAFT + CYLINDER HEAD

Unit: mm (in)

ITEM	STANDARD		LIMIT
Cam height	IN.	33.710—33.750 (1.3272—1.3287)	33.410 (1.3154)
	EX.	33.700—33.740 (1.3268—1.3283)	33.400 (1.3150)
Camshaft journal oil clearance	Right & Center	0.032—0.066 (0.0013—0.0026)	0.150 (0.0059)
	Left	0.028—0.059 (0.0011—0.0023)	0.150 (0.0059)
Camshaft journal holder I.D.	Right & Center	22.012—22.025 (0.8666—0.8671)	—
	Left	17.512—17.525 (0.6894—0.6900)	—
Camshaft journal O.D.	Right & Center	21.959—21.980 (0.8645—0.8654)	—
	Left	17.466—17.484 (0.6877—0.6883)	—
Camshaft runout	—		0.10 (0.004)
Rocker arm I.D.	IN. & EX.	12.000—12.018 (0.4724—0.4731)	—
Rocker arm shaft O.D.	IN. & EX.	11.973—11.984 (0.4714—0.4718)	—
Cylinder head distortion	—		0.05 (0.002)
Cylinder head cover distortion	—		0.05 (0.002)

## CYLINDER + PISTON + PISTON RING

Unit: mm (in)

ITEM	STANDARD		LIMIT
Piston to cylinder clearance	0.020—0.030 (0.0008—0.0012)		0.120 (0.0047)
Cylinder bore	100.000—100.015 (3.937—3.9376)		Nicks or Scratches
Piston diam.	99.975—99.990 (3.9360—3.9366) Measure at 21 mm (0.8 in) from the skirt end.		99.880 (3.9323)
Cylinder distortion	—		0.05 (0.002)
Piston ring free end gap	1st R	Approx. 13.5 (0.53)	10.8 (0.43)
	2nd R	Approx. 11.4 (0.45)	9.1 (0.36)
Piston ring end gap	1st	0.30—0.45 (0.012—0.018)	0.50 (0.020)
	2nd	0.45—0.60 (0.018—0.024)	1.00 (0.039)
Compression pressure (Automatic decomp. actuated)	Approx. 850 kPa (8.5 kg/cm <sup>2</sup> ) 120 psi		—



ITEM	STANDARD		LIMIT
Piston ring to groove clearance	1st	—	0.180 (0.0071)
	2nd	—	0.150 (0.0059)
Piston ring groove width	1st	1.230–1.250 (0.048–0.049)	—
	2nd	1.210–1.230 (0.047–0.048)	—
	Oil	2.810–2.830 (0.110–0.111)	—
Piston ring thickness	1st	1.170–1.190 (0.0461–0.0469)	—
	2nd	1.150–1.170 (0.0453–0.0461)	—
Piston pin bore	23.002–23.008 (0.9056–0.9058)		23.030 (0.9067)
Piston pin O.D.	22.996–23.000 (0.9054–0.9055)		22.980 (0.9047)

**CONROD + CRANKSHAFT**

Unit: mm (in)

ITEM	STANDARD	LIMIT
Conrod small end I.D.	23.006–23.014 (0.9057–0.9061)	23.040 (0.9071)
Conrod deflection	—	3.0 (0.12)
Conrod big end side clearance	0.10–0.65 (0.004–0.026)	1.00 (0.039)
Conrod big end width	24.95–25.00 (0.982–0.984)	—
Crankshaft runout	—	0.05 (0.002)
Crank web to web width	71.0 ± 0.1 (2.795 ± 0.004)	—

**OIL PUMP**

ITEM	STANDARD	LIMIT
Oil pump reduction ratio	1.633 (61/28 x 30/20 x 15/30)	—
Oil pressure (at 60°C, 140°F)	Above 30 kPa (0.3 kg/cm <sup>2</sup> , 4.3 psi) Below 70 kPa (0.7 kg/cm <sup>2</sup> , 10.0 psi) at 3 000 r/min.	—

**CLUTCH**

Unit: mm (in)

ITEM	STANDARD		LIMIT
Clutch lever play	10–15 (0.4–0.6)		—
Drive plate thickness	No. 1 & No. 2	2.9–3.1 (0.11–0.12)	2.6 (0.10)
Driven plate distortion	—		0.10 (0.004)
Clutch spring free length	—		33.0 (1.30)

**TRANSMISSION + DRIVE CHAIN**

Unit: mm (in) Except ratio

ITEM	STANDARD		LIMIT
Primary reduction ratio	2.178 (61/28)		—
Final reduction ratio	E-03,28,33	2.800 (42/15)	—
	The others	2.733 (41/15)	—
Gear ratios	Low	2.416 (29/12)	—
	2nd	1.625 (26/16)	—
	3rd	1.238 (26/21)	—
	4th	1.000 (21/21)	—
	Top	0.826 (19/23)	—
Shift fork to groove clearance	0.10–0.30 (0.004–0.012)		0.50 (0.020)
Shift fork groove width	5.0–5.1 (0.197–0.200)		—
Shift fork thickness	4.8–4.9 (0.189–0.193)		—
Drive chain	Type	DAIDO: DID525V9	
	Links	110	
	20-pitch length	—	319.4 (12.57)
Drive chain slack	30–45 (1.2–1.8)		—

## CARBURETOR

ITEM	SPECIFICATION			
	E-03	E-33	E-28	E-18
Carburetor type	MIKUNI BST40SS	←	←	←
Bore size	40 mm	←	←	←
I.D. No.	32E1	32E6	32E5	32E2
Idle r/min.	1 500 ± 100 r/min.	←	←	1 500 ± 50 r/min.
Float height	14.7 ± 1.0 mm (0.58 ± 0.04 in)	←	←	←
Main jet (M.J.)	# 140	←	# 140	# 137.5
Jet needle (J.N.)	6F23	←	6F19-3rd	6H21-4th
Needle jet (N.J.)	Y-5M	←	Y-5	←
Throttle valve (Th.V.)	# 95	←	←	←
Pilot jet (P.J.)	# 42.5	←	# 42.5	←
Starter jet (G.S.)	# 40	←	←	←
Pilot screw (P.S.)	PRE-SET	←	PRE-SET (1½ turns back)	PRE-SET (1.0 turn back)
Throttle cable play (pulling cable)	0.5–1.0 mm (0.02–0.04 in)	←	←	←
Starter cable play	0.5–1.0 mm (0.02–0.04 in)	←	←	←

## CARBURETOR

ITEM	SPECIFICATION			
	E-02,04,34	E-37	E-17,22,24	U-type E-22
Carburetor type	MIKUNI BST40SS	←	←	←
Bore size	40 mm	←	←	←
I.D. No.	32E0	32E8	32E3	32E4
Idle r/min.	1 500 ± 100 r/min.	←	←	←
Float height	14.7 ± 1.0 mm (0.58 ± 0.04 in)	←	←	←
Main jet (M.J.)	# 140	←	←	←
Jet needle (J.N.)	6F19-3rd	←	←	←
Needle jet (N.J.)	Y-5	←	←	←
Throttle valve (Th.V.)	# 95	←	←	←
Pilot jet (P.J.)	# 42.5	←	←	←
Starter jet (G.S.)	# 40	←	←	←
Pilot screw (P.S.)	PRE-SET (1½ turns back)	←	PRE-SET (1.0 turn back)	PRE-SET (1¼ turns back)
Throttle cable play (pulling cable)	0.5–1.0 mm (0.02–0.04 in)	←	←	←
Starter cable play	0.5–1.0 mm (0.02–0.04 in)	←	←	←

## ELECTRICAL

Unit: mm (in)

ITEM		SPECIFICATION		NOTE
Ignition timing		10° B.T.D.C. at 1 500 r/min.		
Spark plug	Type	ND.: U31ESR-N N.G.K.: CR10E		
	Gap	0.7–0.8 (0.028–0.031)		
Spark performance		Over 8 (0.3) at 1 atm.		
Ignition coil resistance	Primary	0.07–0.12 Ω		B–B/W
	Secondary	23–25 kΩ		Plug cap– Plug cap
Generator coil resistance	Charging	0.5–0.9 Ω		Y–Y
	Power source	0.1–0.2 Ω		B–W
	Pick-up	170–256 Ω		BI–G
Generator no-load voltage		More than 75 V(AC) at 5 000 r/min.		
Generator Max. output		Approx. 200W at 5 000 r/min.		
Regulated voltage		13.0–16.0 V at 5 000 r/min.		
Starter relay resistance		3–5 Ω		
Battery	Type designation	YTX9-BS		
	Capacity	12V 28.8 kC (8Ah)/10 HR		
	Standard electrolyte S.G.	1.320 at 20°C (68°F)		
Fuse size	Main	30 A		
	Headlight (H)	10 A		
	Headlight (L)	10 A		

## WATTAGE

Unit: W

ITEM		SPECIFICATION	
		E-03,24,28,33	The others
Headlight	HI	60	←
	LO	55	←
Parking or position light			4
Tail/Brake light		5/21	←
Turn signal light		21	←
Speedometer light		3	←
Turn signal indicator light		2	←
High beam indicator light		2	←
Neutral indicator light		2	←
License light		5	←

## BRAKE + WHEEL

Unit: mm (in)

ITEM		STANDARD	LIMIT
Rear brake pedal height		5 (0.2)	—
Brake disc thickness	Front	4.0 ± 0.2 (0.157 ± 0.008)	3.5 (0.14)
	Rear	4.5 ± 0.2 (0.177 ± 0.008)	4.0 (0.16)
Brake disc runout		—	0.30 ( 0.012 )

ITEM	STANDARD		LIMIT
Master cylinder bore	Front	12.700–12.743 (0.5000–0.5017)	—
	Rear	12.700–12.743 (0.5000–0.5017)	—
Master cylinder piston diam.	Front	12.657–12.684 (0.4983–0.4994)	—
	Rear	12.657–12.684 (0.4983–0.4994)	—
Brake caliper cylinder bore	Front	27.000–27.050 (1.0630–1.0650)	—
	Rear	30.23–30.28 (1.1902–1.1921)	—
Brake caliper piston diam.	Front	26.90–26.95 (1.0591–1.0610)	—
	Rear	30.16–30.18 (1.1874–1.1882)	—
Wheel rim runout	Axial	—	2.0 (0.08)
	Radial	—	2.0 (0.08)
Wheel axle runout	Front	—	0.25 (0.010)
	Rear	—	0.25 (0.010)
Tire rim size	Front	21 x 1.85	—
	Rear	17 x MT2.50	—
Tire size	Front	90/90-21 54S	—
	Rear	120/90-17 64S	—
Tire tread depth	Front	—	3.0 (0.12)
	Rear	—	3.0 (0.12)

**SUSPENSION**

Unit: mm (in)

ITEM	STANDARD	LIMIT	NOTE
Front fork stroke	260 (10.2)	—	
	220 (8.7)	—	Low seat
Front fork spring free length	—	548 (21.6)	
Front fork oil level	164 (6.5)	—	
	150 (5.9)	—	Low seat

ITEM	STANDARD	LIMIT	NOTE
Rear shock absorber spring pre-set length	247.5 (9.74)	—	
Rear wheel travel	260 (10.2)	—	
	220 (8.7)	—	Low seat
Swingarm pivot shaft runout	—	0.3 (0.01)	

## TIRE PRESSURE

COLD INFLATION TIRE PRESSURE	SOLO RIDING			DUAL RIDING		
	kPa	kg/cm <sup>2</sup>	psi	kPa	kg/cm <sup>2</sup>	psi
FRONT	150	1.50	22	175	1.75	25
REAR	175	1.75	25	200	2.00	29

## FUEL + OIL

ITEM	SPECIFICATION		NOTE
Fuel type	Use only unleaded gasoline of at least 87 pump octane ( $\frac{R+M}{2}$ ) or 91 octane or higher rated by the research method. Gasoline containing MTBE (Methyl Tertiary Butyl Ether), less than 10% ethanol, or less than 5% methanol with appropriate cosolvents and corrosion inhibitor is permissible.		E-03,33
	Use only unleaded gasoline of at least 87 pump octane ( $\frac{R+M}{2}$ method) or 91 octane or higher rated by the Research Method.		E-28
	Gasoline used should be graded 85-95 octane or higher. An unleaded gasoline is recommended.		The others
Fuel tank including reserve	12 L (3.2/2.6 US/Imp gal)		E-33
	reserve	13 L (3.4/2.9 US/Imp gal)	The others
	3.0 L (0.8/0.7 US/Imp gal)		
Engine oil type	SAE 10W/40, API SE, SF or SG		
Engine oil capacity	Change	2 300 ml (2.4/2.0 US/Imp qt)	
	Filter change	2 400 ml (2.5/2.1 US/Imp qt)	
	Overhaul	2 600 ml (2.7/2.3 US/Imp qt)	
Front fork oil type	Fork oil # 10		
Front fork oil capacity (each leg)	565 ml (19.1/19.9 US/Imp oz)		
	563 ml (19.0/19.8 US/Imp oz)		Low seat
Brake fluid type	DOT 4		

# **EMISSION CONTROL INFORMATION**

## **CONTENTS**

<b>EMISSION CONTROL CARBURETOR COMPONENTS .....</b>	<b>8- 1</b>
<b>EVAPORATIVE EMISSION CONTROL SYSTEM .....</b>	<b>8- 2</b>
<b>CANISTER HOSE ROUTING .....</b>	<b>8- 3</b>

## EMISSION CONTROL CARBURETOR COMPONENTS

DR650SE motorcycles are equipped with precision, manufactured carburetors for emission level control. These carburetors require special mixture control components and other precision adjustments to function properly.

There are several carburetor mixture control components in each carburetor assembly. Three (3) of these components are machined to much closer tolerances than standard machined carburetor jets. These three (3) particular jets—MAIN JET, NEEDLE JET, PILOT JET—must not be replaced by standard jets. To aid in identifying these three (3) jets a different design of letter and number are used. If replacement of these close tolerance jets becomes necessary, be sure to replace them with the same type close tolerance jets marked as in the examples shown below.

The jet needle is also of special manufacture. Only one clip position is provided on the jet needle. If replacement becomes necessary the jet needle may only be replaced with an equivalent performing replacement component. Suzuki recommends that Genuine Suzuki Parts be utilized whenever possible for the best possible performance and durability.

Conventional Figures Used on Standard Tolerance Jet Components	<b>1 2 3 4 5 6 7 8 9 0</b>
Emission Type Figures Used on Close Tolerance Jet Components	<i>1 2 3 4 5 6 7 8 9 0</i>

The carburetor specifications for the emission-controlled DR650SE are as follows.

Carburetor I.D. No.	Main Jet	Needle Jet	Jet Needle	Pilot Jet	Pilot Screw
32E6 (California model only)	#14□	Y-5M	6F23	#42.5	PRE-SET
32E1					

Adjusting, interfering with, improper replacement, or resetting of any of the carburetor components may adversely affect carburetor performance and cause the motorcycle to exceed the exhaust emission level limits. If unable to effect repairs, contact the distributors representative for further technical information and assistance.



## EVAPORATIVE EMISSION CONTROL SYSTEM (California model only)

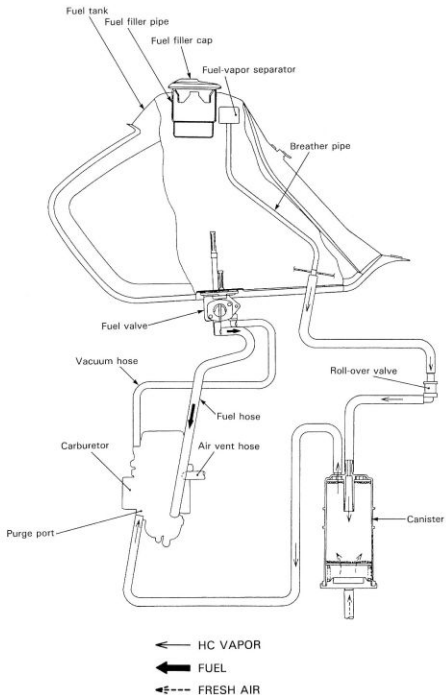

## CANISTER HOSE ROUTING (California model only)

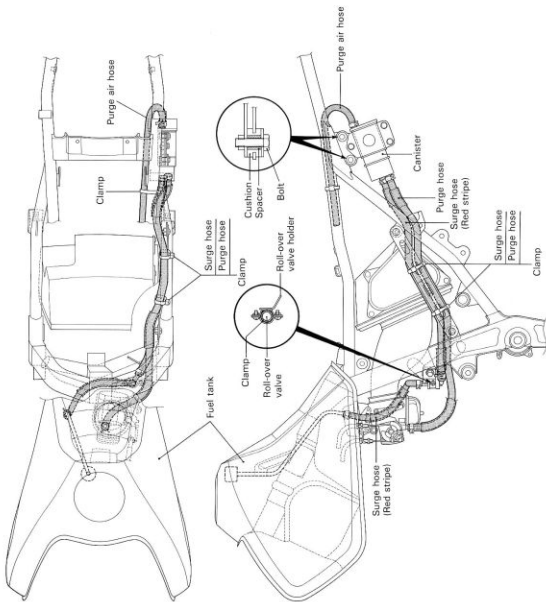

# DR650SEV/W/X/Y ('97/'98/'99/'00-MODEL)

## CONTENTS

<i>SPECIFICATIONS</i> .....	9- 1
<i>SERVICE DATA</i> .....	9- 3
<i>WIRING DIAGRAM</i> .....	9-11

## SPECIFICATIONS

### DIMENSIONS AND DRY MASS

Overall length .....	2 345 mm (92.3 in) .....	E-17, 18, 22
	2 325 mm (91.5 in) .....	E-17, 18, 22 (Low seat)
	2 255 mm (88.8 in) .....	Others
	2 235 mm (88.0 in) .....	Others (Low seat)
Overall width .....	865 mm (34.1 in)	
Overall height .....	1 205 mm (47.4 in)	
	1 165 mm (45.9 in) .....	(Low seat)
Wheelbase .....	1 490 mm (58.7 in)	
	1 475 mm (58.1 in) .....	(Low seat)
Ground clearance .....	265 mm (10.4 in)	
	225 mm ( 8.9 in) .....	(Low seat)
Seat height .....	885 mm (34.8 in)	
	845 mm (33 in) .....	(Low seat)
Dry mass .....	147 kg (324 lbs)	

### ENGINE

Type .....	Four-stroke, air-cooled, with SACS, OHC
Valve clearance (IN) .....	0.08–0.13 mm (0.003–0.005 in)
(EX) .....	0.17–0.22 mm (0.007–0.009 in)
Number of cylinders .....	1
Bore .....	100 mm (3.937 in)
Stroke .....	82 mm (3.228 in)
Piston displacement .....	644 cm <sup>3</sup> (39.3 cu. in)
Compression ratio .....	9.5 : 1
Carburetor .....	BST40, single
Air cleaner .....	Polyurethane foam element
Starter system .....	Electric
Lubrication system .....	Wet sump

### TRANSMISSION

Clutch .....	Wet multi-plate type	
Transmission .....	5-speed constant mesh	
Gearshift pattern .....	1-down, 4-up	
Primary reduction ratio .....	2.178 (61/28)	
Gear ratios, Low .....	2.416 (29/12)	
2nd .....	1.625 (26/16)	
3rd .....	1.238 (26/21)	
4th .....	1.000 (21/21)	
Top .....	0.826 (19/23)	
Final reduction ratio .....	2.800 (42/15) .....	E-03, 28, 33
	2.733 (41/15) .....	Others
Drive chain .....	DID525 V9, 110 links	

**CHASSIS**

Front suspension .....	Telescopic, coil spring, oil damped
Rear suspension .....	Link type, coil spring, gas/oil damped, spring pre-load fully adjustable, compression damping force adjustable
Front fork stroke .....	260 mm (10.2 in)
Rear wheel travel .....	220 mm ( 8.7 in) ..... (Low seat)
	260 mm (10.2 in)
	220 mm ( 8.7 in) ..... (Low seat)
Steering angle .....	43°
Caster .....	28° 30'
Trail .....	111 mm (4.37 in)
Turning radius .....	2.5 m (8.2 ft)
Front brake .....	Disc brake
Rear brake .....	Disc brake
Front tire size .....	90/90-21 54S, tube type
Rear tire size .....	120/90-17 64S, tube type

**ELECTRICAL**

Ignition type .....	Electronic ignition (CDI)
Ignition timing .....	10° B.T.D.C. at 1 500 rpm
Spark plug .....	NGK CR10E or DENSO U31ESR-N
Battery .....	12V 28.8 kC (8 Ah)/10 HR
Generator .....	Three-phase A.C. generator
Fuse .....	30/10/10A
Headlight .....	12V 60/55W
Parking or city light .....	12V 4W ..... except E-03, 24, 28, 33
Turn signal light .....	12V 21W
Brake light/Taillight .....	12V 21/5W
License plate light .....	12V 5W
Speedometer light .....	12V 3W
Neutral indicator light .....	12V 2W
High beam indicator light .....	12V 2W
Turn signal indicator light .....	12V 2W

**CAPACITIES**

Fuel tank, including reserve .....	12.0 L (3.2/2.6 US/lmp gal) ..... E-33
	13.0 L (3.4/2.9 US/lmp gal) ..... Others
reserve .....	3.0 L (0.8/0.7 US/lmp gal)
Engine oil, oil change .....	2 300 ml (2.4/2.0 US/lmp qt)
with filter change .....	2 400 ml (2.5/2.1 US/lmp qt)
overhaul .....	2 600 ml (2.7/2.3 US/lmp qt)
Front fork oil (each leg) .....	565 ml (19.1/19.9 US/lmp oz)
	563 ml (19.0/19.8 US/lmp oz) ..... (Low seat)

## SERVICE DATA

## VALVE + GUIDE

Unit: mm (in)

ITEM		STANDARD	LIMIT
Valve diam.	IN.	33 (1.3)	—
	EX.	28 (1.1)	—
Valve clearance (when engine is cold)	IN.	0.08–0.13 (0.003–0.005)	—
	EX.	0.17–0.22 (0.0067–0.0087)	—
Valve guide to valve stem clearance	IN.	0.010–0.037 (0.0004–0.0015)	—
	EX.	0.030–0.057 (0.0012–0.0022)	—
Valve stem deflection	IN. & EX.	—	0.35 (0.014)
Valve guide I.D.	IN. & EX.	5.500–5.512 (0.2165–0.2170)	—
Valve stem O.D.	IN.	5.475–5.490 (0.2156–0.2161)	—
	EX.	5.455–5.470 (0.2148–0.2154)	—
Valve stem runout	IN. & EX.	—	0.05 (0.002)
Valve head thickness	IN. & EX.	—	0.5 (0.02)
Valve stem end length	IN. & EX.	—	2.7 (0.11)
Valve seat width	IN. & EX.	0.9–1.1 (0.035–0.043)	—
Valve head radial runout	IN. & EX.	—	0.03 (0.001)
Valve spring free length (IN. & EX.)	INNER	—	34.4 (1.35)
	OUTER	—	38.1 (1.50)
Valve spring tension (IN. & EX.)	INNER	5.9–6.7 kg (13.0–14.8 lbs) at length 27.5 mm (1.1 in)	—
	OUTER	13.8–15.8 kg (30.4–34.8 lbs) at length 31.0 mm (1.2 in)	—

**CAMSHAFT + CYLINDER HEAD**

Unit: mm (in)

ITEM	STANDARD		LIMIT
Cam height	IN.	33.710—33.750 (1.3272—1.3287)	33.410 (1.3154)
	EX.	33.700—33.740 (1.3268—1.3283)	33.400 (1.3150)
Camshaft journal oil clearance	Right & Center	0.032—0.066 (0.0013—0.0026)	0.150 (0.0059)
	Left	0.028—0.059 (0.0011—0.0023)	0.150 (0.0059)
Camshaft journal holder I.D.	Right & Center	22.012—22.025 (0.8666—0.8671)	—
	Left	17.512—17.525 (0.6894—0.6900)	—
Camshaft journal O.D.	Right & Center	21.959—21.980 (0.8645—0.8654)	—
	Left	17.466—17.484 (0.6877—0.6883)	—
Camshaft runout	—		0.10 (0.004)
Rocker arm I.D.	IN. & EX.	12.000—12.018 (0.4724—0.4731)	—
Rocker arm shaft O.D.	IN. & EX.	11.973—11.984 (0.4714—0.4718)	—
Cylinder head distortion	—		0.05 (0.002)
Cylinder head cover distortion	—		0.05 (0.002)

**CYLINDER + PISTON + PISTON RING**

Unit: mm (in)

ITEM	STANDARD		LIMIT
Piston to cylinder clearance	0.020—0.030 (0.0008—0.0012)		0.120 (0.0047)
Cylinder bore	100.000—100.015 (3.937—3.9376)		Nicks or Scratches
Piston diam.	99.975—99.990 (3.9360—3.9366) Measure at 21 mm (0.8 in) from the skirt end.		99.880 (3.9323)
Cylinder distortion	—		0.05 (0.002)
Piston ring free end gap	1st	R	Approx. 13.5 (0.53)
	2nd	R	Approx. 11.4 (0.45)
Piston ring end gap	1st	0.30—0.45 (0.012—0.018)	
	2nd	0.45—0.60 (0.018—0.024)	
Compression pressure (Automatic decomp. actuated)	Approx. 850 kPa (8.5 kg/cm <sup>2</sup> ) 120 psi		—

ITEM	STANDARD		LIMIT
Piston ring to groove clearance	1st	—	0.180 (0.0071)
	2nd	—	0.150 (0.0059)
Piston ring groove width	1st	1.230–1.250 (0.048–0.049)	—
	2nd	1.210–1.230 (0.047–0.048)	—
	Oil	2.810–2.830 (0.110–0.111)	—
Piston ring thickness	1st	1.170–1.190 (0.0461–0.0469)	—
	2nd	1.150–1.170 (0.0453–0.0461)	—
Piston pin bore	23.002–23.008 (0.9056–0.9058)		23.030 (0.9067)
Piston pin O.D.	22.996–23.000 (0.9054–0.9055)		22.980 (0.9047)

**CONROD + CRANKSHAFT**

Unit: mm (in)

ITEM	STANDARD	LIMIT
Conrod small end I.D.	23.006–23.014 (0.9057–0.9061)	23.040 (0.9071)
Conrod deflection	—	3.0 (0.12)
Conrod big end side clearance	0.10–0.65 (0.004–0.026)	1.00 (0.039)
Conrod big end width	24.95–25.00 (0.982–0.984)	—
Crankshaft runout	—	0.05 (0.002)
Crank web to web width	71.0 ± 0.1 (2.795 ± 0.004)	—

**OIL PUMP**

ITEM	STANDARD	LIMIT
Oil pump reduction ratio	1.633 (61/28 x 30/20 x 15/30)	—
Oil pressure (at 60°C, 140°F)	Above 30 kPa (0.3 kg/cm <sup>2</sup> , 4.3 psi) Below 70 kPa (0.7 kg/cm <sup>2</sup> , 10.0 psi) at 3 000 r/min.	—



**CLUTCH**

Unit: mm (in)

ITEM	STANDARD		LIMIT
Clutch lever play	10—15 (0.4—0.6)		—
Drive plate thickness	No.1 & No.2	2.9—3.1 (0.11—0.12)	2.6 (0.10)
Driven plate distortion	—		0.10 (0.004)
Clutch spring free length	—		33.0 (1.30)

**TRANSMISSION + DRIVE CHAIN**

Unit: mm (in) Except ratio

ITEM	STANDARD		LIMIT
Primary reduction ratio	2.178 (61/28)		—
Final reduction ratio	E-03,28,33	2.800 (42/15)	—
	The others	2.733 (41/15)	—
Gear ratios	Low	2.416 (29/12)	—
	2nd	1.625 (26/16)	—
	3rd	1.238 (26/21)	—
	4th	1.000 (21/21)	—
	Top	0.826 (19/23)	—
Shift fork to groove clearance	0.10—0.30 (0.004—0.012)		0.50 (0.020)
Shift fork groove width	5.0—5.1 (0.197—0.200)		—
Shift fork thickness	4.8—4.9 (0.189—0.193)		—
Drive chain	Type	DAIDO: DID525V9	—
	Links	110	—
	20-pitch length	—	319.4 (12.57)
Drive chain slack	30—45 (1.2—1.8)		—

## CARBURETOR

ITEM	SPECIFICATION			
	E-03	E-33	E-28	E-18
Carburetor type	MIKUNI BST40SS	←	←	←
Bore size	40 mm	←	←	←
I.D. No.	32E1	32E6	32E1	32E2
Idle r/min.	1 500 ± 100 r/min.	←	←	1 500 ± 50 r/min.
Float height	14.7 ± 1.0 mm (0.58 ± 0.04 in)	←	←	←
Main jet (M.J.)	# 140	←	←	# 137.5
Jet needle (J.N.)	6F23	←	←	6H21-4th
Needle jet (N.J.)	Y-5M	←	←	←
Throttle valve (Th.V.)	# 95	←	←	←
Pilot jet (P.J.)	# 42.5	←	←	←
Starter jet (G.S.)	# 40	←	←	←
Pilot screw (P.S.)	PRE-SET	←	←	PRE-SET (1.0 turn back)
Throttle cable play (pulling cable)	0.5–1.0 mm (0.02–0.04 in)	←	←	←
Starter cable play	0.5–1.0 mm (0.02–0.04 in)	←	←	←

## CARBURETOR

ITEM	SPECIFICATION			
	E-02,04,34	P-37	E-17,22,24	U-type E-22
Carburetor type	MIKUNI BST40SS	←	←	←
Bore size	40 mm	←	←	←
I.D. No.	32E0	32E8	32E3	32E4
Idle r/min.	1 500 ± 100 r/min.	←	←	←
Float height	14.7 ± 1.0 mm (0.58 ± 0.04 in)	←	←	←
Main jet (M.J.)	# 140	←	←	←
Jet needle (J.N.)	6F19-3rd	←	←	←
Needle jet (N.J.)	Y-5	←	←	←
Throttle valve (Th.V.)	# 95	←	←	←
Pilot jet (P.J.)	# 42.5	←	←	←
Starter jet (G.S.)	# 40	←	←	←
Pilot screw (P.S.)	PRE-SET (1½ turns back)	←	PRE-SET (1.0 turn back)	PRE-SET (1½ turns back)
Throttle cable play (pulling cable)	0.5–1.0 mm (0.02–0.04 in)	←	←	←
Starter cable play	0.5–1.0 mm (0.02–0.04 in)	←	←	←

**ELECTRICAL**

Unit: mm (in)

ITEM		SPECIFICATION		NOTE
Ignition timing		10° B.T.D.C. at 1 500 r/min.		
Spark plug		Type	ND.: U31ESR-N N.G.K.: CR10E	
		Gap	0.7–0.8 (0.028–0.031)	
Spark performance		Over 8 (0.3) at 1 atm.		
Ignition coil resistance		Primary	0.07–0.12 Ω	B–B/W
		Secondary	23–25 kΩ	Plug cap– Plug cap
Generator coil resistance		Charging	0.5–0.9 Ω	Y–Y
		Power source	0.1–0.2 Ω	B–W
		Pick-up	170–256 Ω	BI–G
Generator no-load voltage		More than 75 V(AC) at 5 000 r/min.		
Generator Max. output		Approx. 200W at 5 000 r/min.		
Regulated voltage		13.0–16.0 V at 5 000 r/min.		
Starter relay resistance		3–5 Ω		
Battery	Type designation	YTX9-BS		
	Capacity	12V 28.8 kC (8Ah)/10 HR		
	Standard electrolyte S.G.	1.320 at 20°C (68°F)		
Fuse size	Main	30 A		
	Headlight (H)	10 A		
	Headlight (L)	10 A		

**WATTAGE**

Unit:W

ITEM		SPECIFICATION	
		E-03,24,28,33	Other markets
Headlight	HI	60	←
	LO	55	←
Parking or position light			4
Tail/Brake light		5/21	←
Turn signal light		21	←
Speedometer light		3	←
Turn signal indicator light		2	←
High beam indicator light		2	←
Neutral indicator light		2	←
License light		5	←

**BRAKE + WHEEL**

Unit: mm (in)

ITEM	STANDARD		LIMIT
Rear brake pedal height	5 (0.2)		—
Brake disc thickness	Front	4.0 ± 0.2 (0.157 ± 0.008)	3.5 (0.14)
	Rear	4.5 ± 0.2 (0.177 ± 0.008)	4.0 (0.16)
Brake disc runout	—		0.30 ( 0.012 )

ITEM		STANDARD	LIMIT
Master cylinder bore	Front	12.700—12.743 (0.5000—0.5017)	—
	Rear	12.700—12.743 (0.5000—0.5017)	—
Master cylinder piston diam.	Front	12.657—12.684 (0.4983—0.4994)	—
	Rear	12.657—12.684 (0.4983—0.4994)	—
Brake caliper cylinder bore	Front	27.000—27.050 (1.0630—1.0650)	—
	Rear	30.23—30.28 (1.1902—1.1921)	—
Brake caliper piston diam.	Front	26.90—26.95 (1.0591—1.0610)	—
	Rear	30.16—30.18 (1.1874—1.1882)	—
Wheel rim runout	Axial	—	2.0 (0.08)
	Radial	—	2.0 (0.08)
Wheel axle runout	Front	—	0.25 (0.010)
	Rear	—	0.25 (0.010)
Tire rim size	Front	J21 × 1.85	—
	Rear	J17 × MT2.50	—
Tire size	Front	90/90-21 54S	—
	Rear	120/90-17 64S	—
Tire tread depth	Front	—	3.0 (0.12)
	Rear	—	3.0 (0.12)

**SUSPENSION**

Unit: mm (in)

ITEM	STANDARD	LIMIT	NOTE
Front fork stroke	260 (10.2)	—	
	220 (8.7)	—	Low seat
Front fork spring free length	—	548 (21.6)	
Front fork oil level	164 (6.5)	—	
	150 (5.9)	—	Low seat

ITEM	STANDARD	LIMIT	NOTE
Rear shock absorber spring pre-set length	247.5 (9.74)	—	
Rear wheel travel	260 (10.2)	—	
	220 (8.7)	—	Low seat
Swingarm pivot shaft runout	—	0.3 (0.01)	

## TIRE PRESSURE

COLD INFLATION TIRE PRESSURE	SOLO RIDING			DUAL RIDING		
	kPa	kg/cm <sup>2</sup>	psi	kPa	kg/cm <sup>2</sup>	psi
FRONT	150	1.50	22	175	1.75	25
REAR	175	1.75	25	200	2.00	29

## FUEL + OIL

ITEM	SPECIFICATION		NOTE
Fuel type	Use only unleaded gasoline of at least 87 pump octane ( $\frac{R+M}{2}$ ) or 91 octane or higher rated by the research method. Gasoline containing MTBE (Methyl Tertiary Butyl Ether), less than 10% ethanol, or less than 5% methanol with appropriate cosolvents and corrosion inhibitor is permissible.		E-03,33
	Use only unleaded gasoline of at least 87 pump octane ( $\frac{R+M}{2}$ method) or 91 octane or higher rated by the Research Method.		E-28
	Gasoline used should be graded 85-95 octane or higher. An unleaded gasoline is recommended.		Other markets
Fuel tank capacity	Including reserve	12 L (3.2/2.6 US/Imp gal)	E-33
		13 L (3.4/2.9 US/Imp gal)	Other markets
	Only reserve	3.0 L (0.8/0.7 US/Imp gal)	
Engine oil type	SAE 10W/40, API SF or SG		
Engine oil capacity	Oil change	2 300 ml (2.4/2.0 US/Imp qt)	
	Oil and filter change	2 400 ml (2.5/2.1 US/Imp qt)	
	Engine overhaul	2 600 ml (2.7/2.3 US/Imp qt)	
Front fork oil type	Fork oil # 10		
Front fork oil capacity (each leg)	565 ml (19.1/19.9 US/Imp oz)		
	563 ml (19.0/19.8 US/Imp oz)		Low seat
Brake fluid type	DOT 4		

# WIRING DIAGRAM

(ON AND AFTER '98-MODEL PRODUCTION)

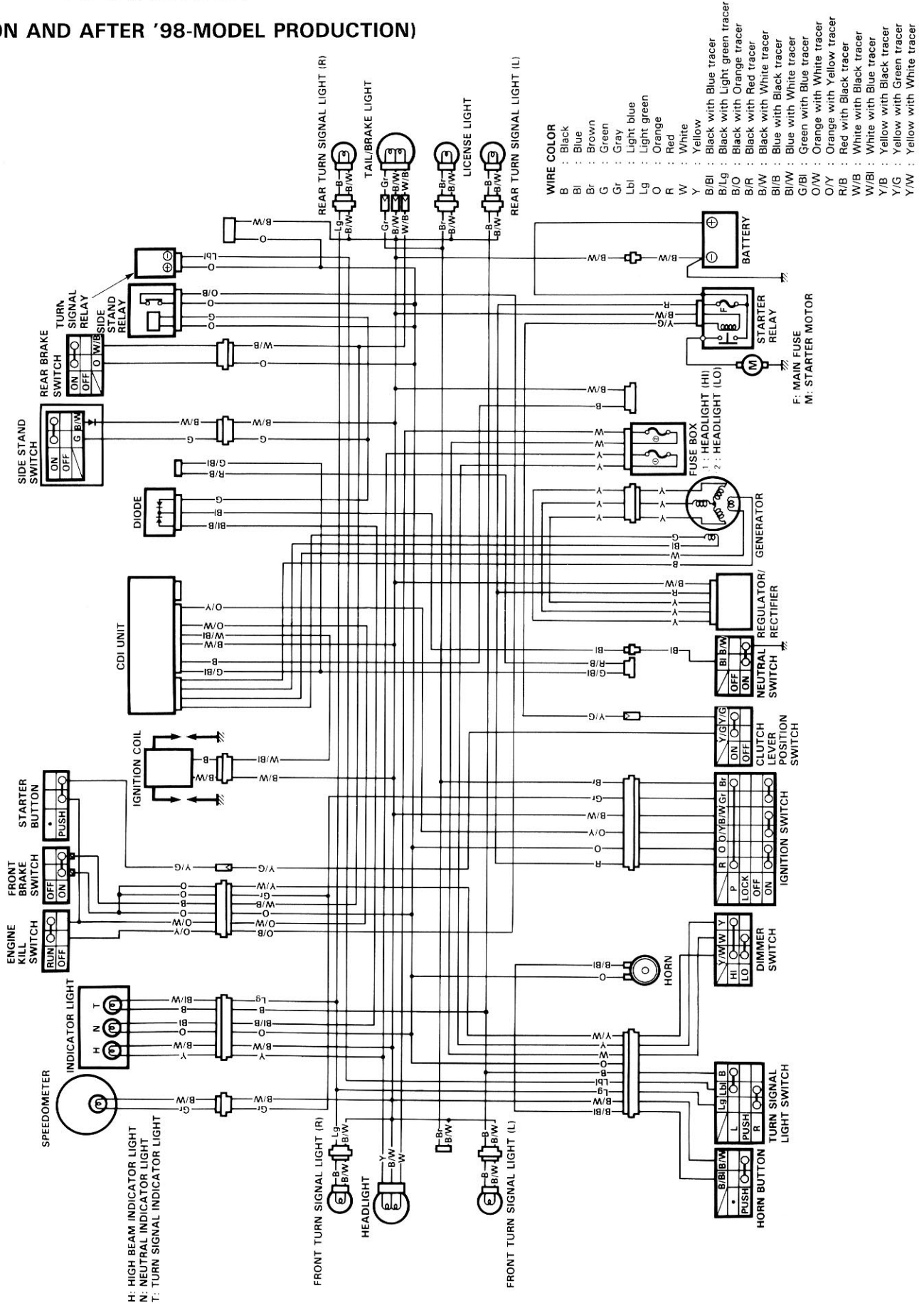

# **DR650SEK1 ('01-MODEL)**

## **CONTENTS**

<b>SPECIFICATIONS .....</b>	<b>10- 1</b>
<b>SERVICE DATA .....</b>	<b>10- 2</b>
<b>LIQUID GASKET .....</b>	<b>10- 10</b>

## SPECIFICATIONS

### DIMENSIONS AND DRY MASS

Overall length .....	2 345 mm (92.3 in) .....	E-17, 26, 22
	2 325 mm (91.5 in) .....	E-17, 26, 22 (Low seat)
	2 255 mm (88.8 in) .....	Others
	2 235 mm (88.0 in) .....	Others (Low seat)
Overall width .....	865 mm (34.1 in)	
Overall height .....	1 205 mm (47.4 in)	
	1 165 mm (45.9 in) .....	(Low seat)
Wheelbase .....	1 490 mm (58.7 in)	
	1 475 mm (58.1 in) .....	(Low seat)
Ground clearance .....	265 mm (10.4 in)	
	225 mm ( 8.9 in) .....	(Low seat)
Seat height .....	885 mm (34.8 in)	
	845 mm (33 in) .....	(Low seat)
Dry mass .....	147 kg (324 lbs)	

### ENGINE

Type .....	Four-stroke, air-cooled, OHC
Valve clearance (IN) .....	0.08 - 0.13 mm (0.003 - 0.005 in)
..... (EX) .....	0.17 - 0.22 mm (0.007 - 0.009 in)
Number of cylinders .....	1
Bore .....	100 mm (3.937 in)
Stroke .....	82 mm (3.228 in)
Displacement .....	644 cm <sup>3</sup> (39.3 cu. in)
Compression ratio .....	9.5 : 1
Carburetor .....	MIKUNI BST40SS, single
Air cleaner .....	Polyurethane foam element
Starter system .....	Electric
Lubrication system .....	Wet sump
Idle speed .....	1 500 ± 100 r/min

### TRANSMISSION

Clutch .....	Wet multi-plate type	
Transmission .....	5-speed constant mesh	
Gearshift pattern .....	1-down, 4-up	
Primary reduction ratio .....	2.178 (61/28)	
Gear ratios, Low .....	2.416 (29/12)	
2nd .....	1.625 (26/16)	
3rd .....	1.238 (26/21)	
4th .....	1.000 (21/21)	
Top .....	0.826 (19/23)	
Final reduction ratio .....	2.600 (42/15) .....	E-03, 26, 33
	2.733 (41/15) .....	Others
Drive chain .....	D/D 525 V8, 110 links	

### CHASSIS

Front suspension .....	Telescopic, coil spring, oil damped	
Rear suspension .....	Link type, coil spring, oil damped, spring preload fully adjustable, compression damping force adjustable	
Front fork stroke .....	260 mm (10.2 in)	
	220 mm ( 8.7 in) .....	(Low seat)
Rear wheel travel .....	260 mm (10.2 in)	
	220 mm ( 8.7 in) .....	(Low seat)
Steering angle .....	43°	
Caster .....	26° 30'	
Tail .....	111 mm (4.37 in)	
Turning radius .....	2.5 m (8.2 ft)	
Front brake .....	Disc brake	
Rear brake .....	Disc brake	
Front tire size .....	90/90-21 54S, tube type	
Rear tire size .....	120/90-17 64S, tube type	

### ELECTRICAL

Ignition type .....	Electronic ignition (CDI)	
Ignition timing .....	10° B.T.D.C. at 1 500 rpm	
Spark plug .....	NGK CR10E or DENSO U31ESR-N	
Battery .....	12V 28.8 kC (8 Ah)/10HR	
Generator .....	Three-phase A.C. generator	
Main fuse .....	30A	
Fuse .....	10/10A	
Headlight .....	12V 60/55W	
Parking or city light .....	12V 4W .....	Except E-03, 24, 26, 33
Turn signal light .....	12V 21W	
Brake light/Tailight .....	12V 21/5W	
License plate light .....	12V 5W	
Speedometer light .....	12V 1.7W	
Neutral indicator light .....	12V 2W	
High beam indicator light .....	12V 2W	
Turn signal indicator light .....	12V 2W	

### CAPACITIES

Fuel tank, including reserve .....	12.0 L (3.2/2.6 US/Imp gal) .....	E-33
reserve .....	13.0 L (3.4/2.9 US/Imp gal) .....	Others
.....	3.0 L (0.8/0.7 US/Imp gal)	
Engine oil, oil change .....	2 300 ml (2.4/2.0 US/Imp qt)	
with filter change .....	2 400 ml (2.5/2.1 US/Imp qt)	
overhaul .....	2 600 ml (2.7/2.3 US/Imp qt)	
Front fork oil (each leg) .....	565 ml (19.1/19.9 US/Imp oz)	
	563 ml (19.0/19.8 US/Imp oz) .....	(Low seat)



**SERVICE DATA****VALVE + GUIDE**

Unit: mm (in)

ITEM		STANDARD	LIMIT
Valve diam.	IN.	33 (1.3)	—
	EX.	28 (1.1)	—
Valve clearance (when engine is cold)	IN.	0.08 – 0.13 (0.003 – 0.005)	—
	EX.	0.17 – 0.22 (0.0067 – 0.0087)	—
Valve guide to valve stem clearance	IN.	0.010 – 0.037 (0.0004 – 0.0015)	—
	EX.	0.030 – 0.057 (0.0012 – 0.0022)	—
Valve stem deflection	IN. & EX.	—	0.35 (0.014)
Valve guide I.D.	IN. & EX.	5.500 – 5.512 (0.2165 – 0.2170)	—
Valve stem O.D.	IN.	5.475 – 5.490 (0.2156 – 0.2161)	—
	EX.	5.455 – 5.470 (0.2148 – 0.2154)	—
Valve stem runout	IN. & EX.	—	0.05 (0.002)
Valve head thickness	IN. & EX.	—	0.5 (0.02)
Valve stem end length	IN. & EX.	—	2.7 (0.11)
Valve seat width	IN. & EX.	0.9 – 1.1 (0.035 – 0.043)	—
Valve head radial runout	IN. & EX.	—	0.03 (0.001)
Valve spring free length (IN. & EX.)	INNER	—	34.4 (1.35)
	OUTER	—	38.1 (1.50)
Valve spring tension (IN. & EX.)	INNER	5.9 – 6.7 kg (13.0 – 14.8 lbs) at length 27.5 mm (1.1 in)	—
	OUTER	13.8 – 15.8 kg (30.4 – 34.8 lbs) at length 31.0 mm (1.2 in)	—

**CAMSHAFT + CYLINDER HEAD**

Unit: mm (in)

ITEM	STANDARD		LIMIT
Cam height	IN.	33.710 – 33.750 (1.3272 – 1.3287)	33.410 (1.3154)
	EX.	33.700 – 33.740 (1.3268 – 1.3283)	33.400 (1.3150)
Camshaft journal oil clearance	Right & Center	0.032 – 0.066 (0.0013 – 0.0026)	0.150 (0.0059)
	Left	0.028 – 0.059 (0.0011 – 0.0023)	0.150 (0.0059)
Camshaft journal holder I.D.	Right & Center	22.012 – 22.025 (0.8666 – 0.8671)	—
	Left	17.512 – 17.525 (0.6894 – 0.6900)	—
Camshaft journal O.D.	Right & Center	21.959 – 21.980 (0.8645 – 0.8654)	—
	Left	17.466 – 17.484 (0.6877 – 0.6883)	—
Camshaft runout	—		0.10 (0.004)
Rocker arm I.D.	IN. & EX.	12.000 – 12.018 (0.4724 – 0.4731)	—
Rocker arm shaft O.D.	IN. & EX.	11.973 – 11.984 (0.4714 – 0.4718)	—
Cylinder head distortion	—		0.05 (0.002)
Cylinder head cover distortion	—		0.05 (0.002)

**CYLINDER + PISTON + PISTON RING**

Unit: mm (in)

ITEM	STANDARD		LIMIT
Piston to cylinder clearance	0.020 – 0.030 (0.0008 – 0.0012)		0.120 (0.0047)
Cylinder bore	100.000 – 100.015 (3.9371 – 3.9376)		Nicks or Scratches
Piston diam.	99.975 – 99.990 (3.9360 – 3.9366) Measure at 21 mm (0.8 in) from the skirt end.		99.880 (3.9323)
Cylinder distortion	—		0.05 (0.002)
Piston ring free end gap	1st	R	Approx. 13.5 (0.53)
	2nd	R	Approx. 11.4 (0.45)
Piston ring end gap	1st	0.30 – 0.45 (0.012 – 0.018)	
	2nd	0.45 – 0.60 (0.018 – 0.024)	
Compression pressure (Automatic decomp. actuated)	Approx. 850 kPa (8.5 kg/cm <sup>2</sup> ) 120 psi		—

ITEM	STANDARD		LIMIT
Piston ring to groove clearance	1st	—	0.180 (0.0071)
	2nd	—	0.150 (0.0059)
Piston ring groove width	1st	1.230 – 1.250 (0.048 – 0.049)	—
	2nd	1.210 – 1.230 (0.047 – 0.048)	—
	Oil	2.810 – 2.830 (0.110 – 0.111)	—
Piston ring thickness	1st	1.170 – 1.190 (0.0461 – 0.0469)	—
	2nd	1.150 – 1.170 (0.0453 – 0.0461)	—
Piston pin bore	23.002 – 23.008 (0.9056 – 0.9058)		23.030 (0.9067)
Piston pin O.D.	22.996 – 23.000 (0.9054 – 0.9055)		22.980 (0.9047)

**CONROD + CRANKSHAFT**

Unit: mm (in)

ITEM	STANDARD	LIMIT
Conrod small end I.D.	23.006 – 23.014 (0.9057 – 0.9061)	23.040 (0.9071)
Conrod deflection	—	3.0 (0.12)
Conrod big end side clearance	0.10 – 0.65 (0.004 – 0.026)	1.00 (0.039)
Conrod big end width	24.95 – 25.00 (0.982 – 0.984)	—
Crankshaft runout	—	0.05 (0.002)
Crank web to web width	71.0 ± 0.1 (2.795 ± 0.004)	—

**OIL PUMP**

ITEM	STANDARD	LIMIT
Oil pump reduction ratio	1.633 (61/28 × 30/20 × 15/30)	—
Oil pressure (at 60°C, 140°F)	Above 30 kPa (0.3 kg/cm <sup>2</sup> , 4.3 psi) Below 70 kPa (0.7 kg/cm <sup>2</sup> , 10.0 psi) at 3 000 r/min.	—

**CLUTCH**

Unit: mm (in)

ITEM	STANDARD		LIMIT
Clutch lever play	10 - 15 (0.4 - 0.6)		—
Drive plate thickness	No.1 & No.2	2.9 - 3.1 (0.11 - 0.12)	2.6 (0.10)
Driven plate distortion	—		0.10 (0.004)
Clutch spring free length	—		33.0 (1.30)

**TRANSMISSION + DRIVE CHAIN**

Unit: mm (in) Except ratio

ITEM	STANDARD		LIMIT
Primary reduction ratio	2.178 (61/28)		—
Final reduction ratio	E-03,28,33	2.800 (42/15)	—
	The others	2.733 (41/15)	—
Gear ratios	Low	2.416 (29/12)	—
	2nd	1.625 (26/16)	—
	3rd	1.238 (26/21)	—
	4th	1.000 (21/21)	—
	Top	0.826 (19/23)	—
Shift fork to groove clearance	0.10 - 0.30 (0.004 - 0.012)		0.50 (0.020)
Shift fork groove width	5.0 - 5.1 (0.197 - 0.200)		—
Shift fork thickness	4.8 - 4.9 (0.189 - 0.193)		—
Drive chain	Type	DAIDO: DID525V9	—
	Links	110	—
	20-pitch length	—	319.4 (12.57)
Drive chain slack	30 - 45 (1.2 - 1.8)		—

## CARBURETOR

ITEM	SPECIFICATION		
	E-03, 28	E-33	E-18
Carburetor type	MIKUNI BST40SS	←	←
Bore size	40 mm	←	←
I.D. No.	32E1	32E6	32E2
Idle r/min.	1 500 ± 100 r/min.		1 500 ± 50 r/min.
Float height	14.7 ± 1.0 mm (0.58 ± 0.04in)	←	←
Main jet (M.J.)	#140	←	#137.5
Jet needle (J.N.)	6F23	←	6H21-4th
Needle jet (N.J.)	Y-5M	←	Y-5
Throttle valve (Th.V.)	#95	←	←
Pilot jet (P.J.)	#42.5	←	←
Starter jet (G.S.)	#40	←	←
Pilot screw (P.S.)	PRE-SET	←	PRE-SET (1.0 turn back)
Throttle cable play (pulling cable)	0.5 – 1.0 mm (0.02 – 0.04 in)	←	←
Starter cable play	0.5 – 1.0 mm (0.02 – 0.04 in)	←	←

## CARBURETOR

ITEM	SPECIFICATION		
	E-04, 34, 54	E-17, 22, 24	U-type E-22
Carburetor type	MIKUNI BST40SS	←	←
Bore size	40 mm	←	←
I.D. No.	32E0	32E3	32E4
Idle r/min.	1 500 ± 100 r/min.	←	←
Float height	14.7 ± 1.0 mm (0.58 ± 0.04 in)	←	←
Main jet (M.J.)	#140	←	←
Jet needle (J.N.)	6F19-3rd	←	←
Needle jet (N.J.)	Y-5	←	←
Throttle valve (Th.V.)	#95	←	←
Pilot jet (P.J.)	#42.5	←	←
Starter jet (G.S.)	#40	←	←
Pilot screw (P.S.)	PRE-SET (1½ turns back)	PRE-SET (1.0 turn back)	PRE-SET (1½ turns back)
Throttle cable play (pulling cable)	0.5 – 1.0 mm (0.02 – 0.04 in)	←	←
Starter cable play	0.5 – 1.0 mm (0.02 – 0.04 in)	←	←

**ELECTRICAL**

Unit: mm (in)

ITEM		SPECIFICATION		NOTE
Ignition timing		10° B.T.D.C. at 1 500 r/min.		
Spark plug		Type	ND: U31ESR-N N.G.K.: CR10E	
		Gap	0.7 – 0.8 (0.028 – 0.031)	
Spark performance		Over 8 (0.3) at 1 atm.		
Ignition coil resistance		Primary	0.07 – 0.12 Ω	B – B/W
		Secondary	23 – 25 kΩ	Plug cap – Plug cap
Generator coil resistance		Charging	0.5 – 0.9 Ω	Y – Y
		Power source	0.1 – 0.2 Ω	B – W
		Pick-up	170 – 256 Ω	BI – G
Generator no-load voltage		More than 75 V (AC) at 5 000 r/min.		
Generator Max. output		Approx. 200 W at 5 000 r/min.		
Regulated voltage		13.0 – 16.0 V at 5 000 r/min.		
Starter relay resistance		3 – 5 Ω		
Battery	Type designation	YTX9-BS		
	Capacity	12V 28.8 kC (8Ah)/10 HR		
	Standard electrolyte S.G.	1.320 at 20°C (68°F)		
Fuse size	Main	30 A		
	Headlight (H)	10 A		
	Headlight (L)	10 A		

**WATTAGE**

Unit: W

ITEM		SPECIFICATION	
		E-03, 24, 28, 33	Other markets
Headlight	HI	60	←
	LO	55	←
Parking or position light			4
Brake light/Tailight		5/21	←
Turn signal light		21	←
Speedometer light		3	←
Turn signal indicator light		2	←
High beam indicator light		2	←
Neutral indicator light		2	←
License light		5	←

**BRAKE + WHEEL**

Unit: mm (in)

ITEM	STANDARD		LIMIT
Rear brake pedal height	5 (0.2)		—
Brake disc thickness	Front	4.0 ± 0.2 (0.157 ± 0.008)	3.5 (0.14)
	Rear	4.5 ± 0.2 (0.177 ± 0.008)	4.0 (0.16)
Brake disc runout	—		0.30 (0.012)

ITEM	STANDARD		LIMIT
Master cylinder bore	Front	12.700 – 12.743 (0.5000 – 0.5017)	—
	Rear	12.700 – 12.743 (0.5000 – 0.5017)	—
Master cylinder piston diam.	Front	12.657 – 12.684 (0.4983 – 0.4994)	—
	Rear	12.657 – 12.684 (0.4983 – 0.4994)	—
Brake caliper cylinder bore	Front	27.000 – 27.050 (1.0630 – 1.0650)	—
	Rear	30.23 – 30.28 (1.1902 – 1.1921)	—
Brake caliper piston diam.	Front	26.90 – 26.95 (1.0591 – 1.0610)	—
	Rear	30.16 – 30.18 (1.1874 – 1.1882)	—
Wheel rim runout	Axial	—	2.0 (0.08)
	Radial	—	2.0 (0.08)
Wheel axle runout	Front	—	0.25 (0.010)
	Rear	—	0.25 (0.010)
Tire rim size	Front	J21 × 1.85	—
	Rear	J17 × MT2.50	—
Tire size	Front	90/90-21 54S	—
	Rear	120/90-17 64S	—
Tire tread depth	Front	—	3.0 (0.12)
	Rear	—	3.0 (0.12)

**SUSPENSION**

Unit: mm (in)

ITEM	STANDARD	LIMIT	NOTE
Front fork stroke	260 (10.2)	—	
	220 (8.7)	—	Low seat
Front fork spring free length	—	548 (21.6)	
Front fork oil level	164 (6.5)	—	
	150 (5.9)	—	Low seat

ITEM	STANDARD	LIMIT	NOTE
Rear shock absorber spring pre-set length	247.5 (9.74)	—	
Rear wheel travel	260 (10.2)	—	
	220 (8.7)	—	Low seat
Swingarm pivot shaft runout	—	0.3 (0.01)	

## TIRE PRESSURE

COLD INFLATION TIRE PRESSURE	SOLO RIDING			DUAL RIDING		
	kPa	kg/cm <sup>2</sup>	psi	kPa	kg/cm <sup>2</sup>	psi
FRONT	150	1.50	22	175	1.75	25
REAR	175	1.75	25	200	2.00	29

## FUEL + OIL

ITEM	SPECIFICATION		NOTE
Fuel type	Use only unleaded gasoline of at least 87 pump octane ( $\frac{B_2M}{L}$ ) or 91 octane or higher rated by the research method. Gasoline containing MTBE (Methyl Tertiary Butyl Ether), less than 10% ethanol, or less than 5% methanol with appropriate cosolvents and corrosion inhibitor is permissible.		E-03, 28, 33
	Gasoline used should be graded 85-95 octane or higher. An unleaded gasoline is recommended.		Other markets
Fuel tank capacity	Including reserve	12 L (3.2/2.6 US/Imp gal)	E-33
		13 L (3.4/2.9 US/Imp gal)	Other markets
	Only reserve	3.0 L (0.8/0.7 US/Imp gal)	
Engine oil type	SAE 10W/40, API SF or SG		
Engine oil capacity	Oil change	2 300 ml (2.4/2.0 US/Imp qt)	
	Oil and filter change	2 400 ml (2.5/2.1 US/Imp qt)	
	Engine overhaul	2 600 ml (2.7/2.3 US/Imp qt)	
Front fork oil type	Fork oil #10		
Front fork oil capacity (each leg)	565 ml (19.1/19.9 US/Imp oz)		
	563 ml (19.0/19.8 US/Imp oz)		Low seat
Brake fluid type	DOT 4		



## LIQUID GASKET

CYLINDER HEAD COVER

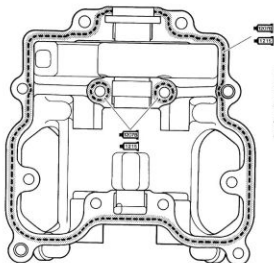

**NOTE:**  
SUZUKI BOND NO.1215  
or NO.1207B has to be  
applied to the cylinder head  
cover and cylinder head.

CYLINDER HEAD

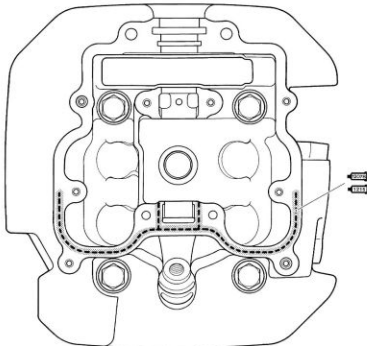

# STARTVORGANG

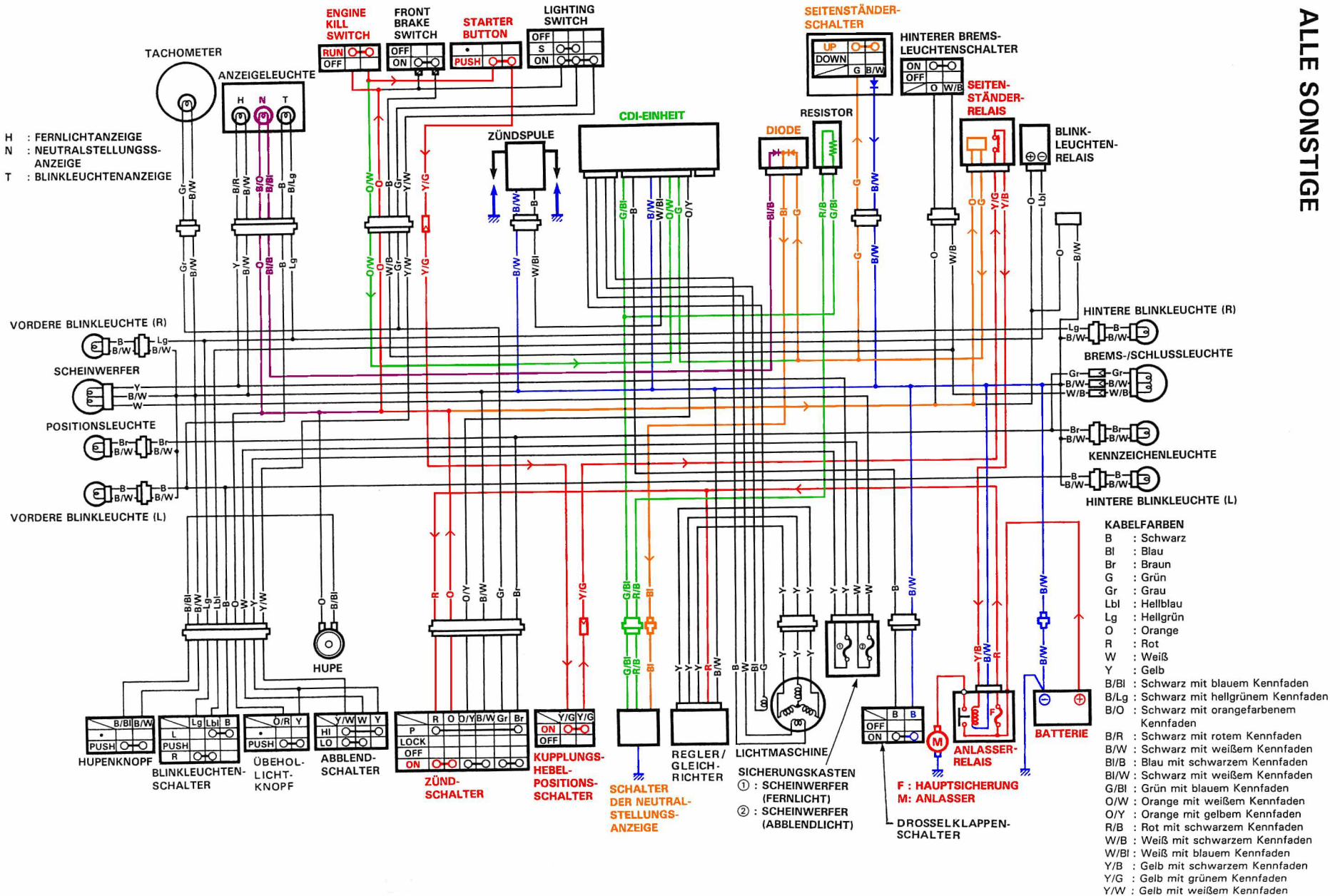

FÜR ALLE SONSTIGE

7-11 WARTUNGSMANUAL